

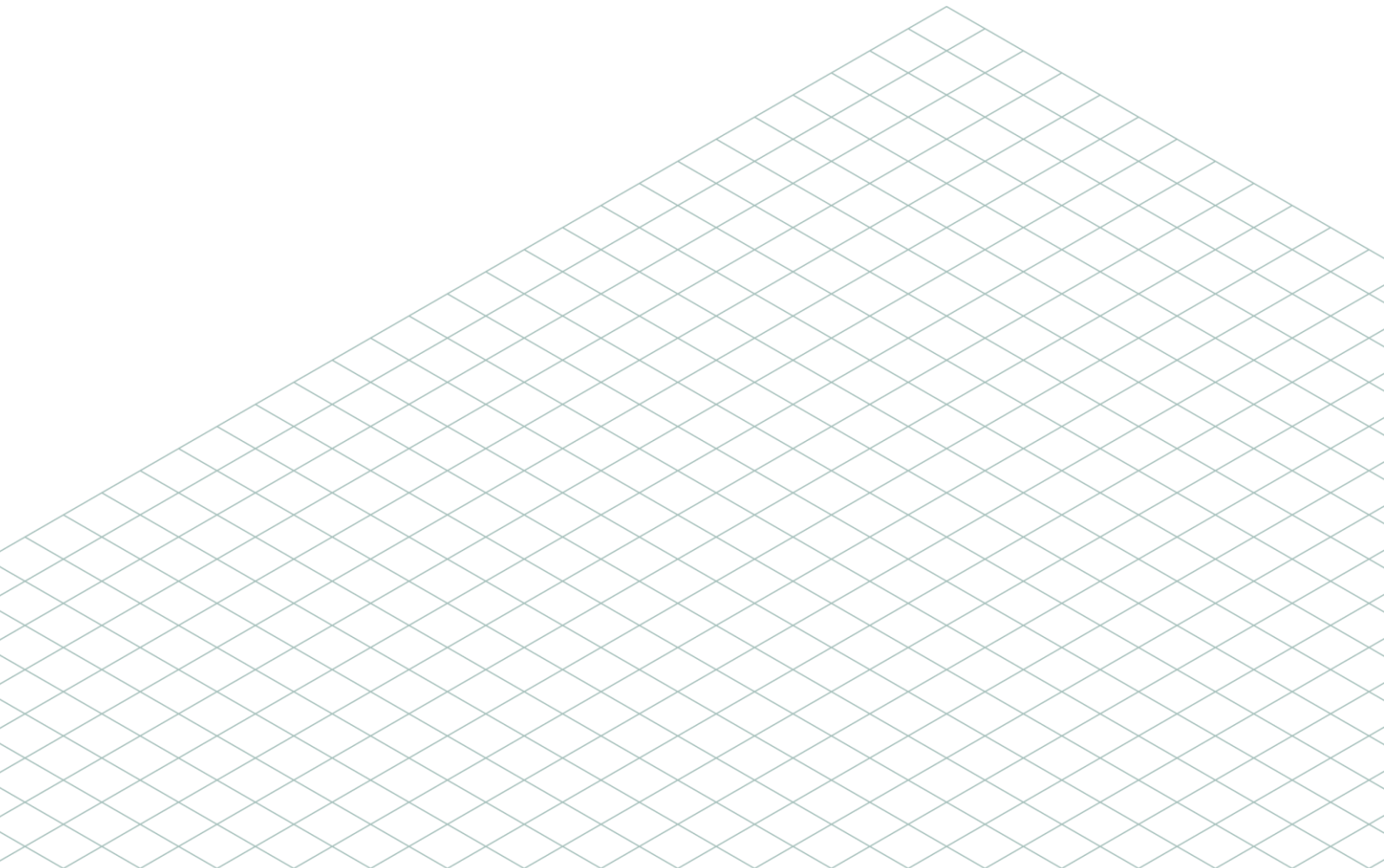

FRAMECAD Steelwise Reference Guide



Disclaimer

This document has been published for the purpose of providing information of a general nature only.

Further, no guarantee, warranty, or any other form of assurance is given as to the accuracy, currency or completeness of the information provided.

Accordingly, any reliance on, or use, by you of any information contained within this document for any purpose whatsoever shall be entirely at your own risk, and any liability to you is expressly disclaimed to the maximum extent permitted by law.

Intellectual Property Notice

ALL INFORMATION CONTAINED IN THIS DOCUMENT IS SUBJECT TO CHANGE WITHOUT NOTICE. THIS DOCUMENT SUPERSEDES ALL PREVIOUS DOCUMENTS.

FRAMECAD® and the FRAMECAD® logo are trademarks of FRAMECAD Limited.

Reproduction of this document and all material included herein is prohibited, except with the prior written consent of FRAMECAD Limited.

Copyright **2026** FRAMECAD Limited.

Confidentiality

This document and all material included herein is confidential to FRAMECAD Limited and must not be disclosed to any other party or used to the detriment of or other than as authorised by FRAMECAD Limited.

This document and all material included herein shall be returned to FRAMECAD Limited Immediately upon request.

Contents

Disclaimer	i
Intellectual Property Notice	i
Confidentiality	i
Contents	ii
1 Introduction	12
2 Setting Commands	13
2.1 BSET – Border Setup	13
2.1.1 Layouts Tab.....	13
2.1.1.1 Client Options:.....	13
2.1.1.2 Sheet Options.....	14
2.1.2 Engineering Tab.....	15
2.1.2.1 Various Tools.....	15
2.1.3 Options Tab.....	16
2.1.3.1 Design Codes.....	16
2.1.3.2 Loading Earthquake Code.....	17
2.1.3.3 Design Options.....	17
2.1.3.4 Drawing Options.....	17
2.1.3.5 Dimension Options	17
2.1.3.6 3D (Colour) Options.....	18
2.1.3.7 Layer Names	18
2.1.3.8 Reference Options	18
2.1.3.9 Gridline Options	19
2.1.3.10 Export Options	19
2.1.3.11 Folder Settings Information.....	20
2.1.3.12 Tooling Option.....	20
2.2 JSET - Floor Settings	20
2.2.1 Layouts Tab.....	22
2.2.1.1 Member Information.....	22
2.2.1.2 Layout Information.....	23
2.2.1.3 Applied Loads	25
2.2.1.4 Ceiling Battens Information	26
2.2.1.5 Creation Options	26
2.2.1.6 Report Options.....	26
2.2.1.7 Labelling Options Information	27
2.2.2 Options Tab.....	27
2.3 PSET - Panel Settings	27
2.3.1 Panels Tab.....	28
2.3.1.1 Panel Information.....	28
2.3.1.2 Panel Widths and Lengths.....	28
2.3.1.3 Opening Options	29
2.3.1.4 Integrity Check Option.....	30
2.3.1.5 Brace Panel Information.....	30
2.3.1.6 Panel Options.....	30
2.3.1.7 Brick Gauge Options	32
2.3.2 Openings Tab	33

2.3.2.1	Common Setting Information.....	33
2.3.3	Options Tab.....	33
2.3.3.1	Ceiling Panel Options Information.....	33
2.3.3.2	Stud Array Options Information.....	33
2.3.3.3	Notch Settings.....	34
2.3.3.4	Labelling Option Information.....	34
2.3.3.5	Folder Settings Information.....	35
2.3.3.6	Detail Sheet Options.....	35
2.4	TSET - Truss Settings.....	35
2.4.1	Layout Tab.....	35
2.4.1.1	Layout Options.....	35
2.4.1.2	Truss Spacings.....	43
2.4.1.3	Truss Spacings Types.....	44
2.4.1.4	Truss Directions.....	44
2.4.1.5	Loads.....	45
2.4.1.6	Batten Spacings.....	45
2.4.1.7	Roof Batten Settings.....	45
2.4.1.8	Ceiling Batten Settings.....	46
2.4.1.9	Valley Supports.....	46
2.4.1.10	Solar Panels.....	47
2.4.1.11	Roof Panel Options.....	47
2.4.2	Options Tab.....	47
2.4.2.1	Height Split Options.....	47
2.4.2.2	Labels Options.....	47
2.4.2.3	Report Options.....	47
2.4.2.4	Detail Sheet Options.....	47
2.4.2.5	Dimension Options.....	48
3	General Commands.....	49
3.1	ADD – Border.....	49
3.2	ADD – Wall.....	49
3.3	ADD – Beam.....	52
3.4	ADD – Post.....	53
3.5	ADD – Opening.....	54
3.6	ADD – Joist.....	55
3.7	ADD – Truss.....	55
3.8	ADD – Truss/Joist/Wall Members.....	56
3.9	C3D – Copy to Model.....	57
3.10	CB – Clear Border.....	57
3.11	CC – Copy Posts.....	58
3.12	CSL - Create Support Line.....	58
3.13	CTH - Convert to Hexagonal End.....	59
3.14	CTR – Centered.....	59
3.15	CV - Copy View.....	60
3.16	DET - Detail/Frame Builder.....	60

3.17	DO_ONCE - Reset CAD Environment.....	61
3.18	ET - Explicit Tool Input.....	61
3.19	FFIND - Find Item	64
3.20	GL – Gridline	65
3.21	IC – Integrity Check	66
3.22	ID – Insert Detail	69
3.23	LA – Label All.....	70
3.24	LI – List Item.....	70
3.24.1	Bath Editor.....	72
3.24.2	Beam Editor	72
3.24.3	Brace Editor.....	74
3.24.4	Fixings Details	74
3.24.5	Floor Member Editor (Webbed Joist)	76
3.24.6	Gridline Editor.....	80
3.24.7	Layout Title	80
3.24.8	Opening Editor.....	81
3.24.9	Post Editor	83
3.24.10	Panel Properties Editor.....	84
3.24.11	Reference Point Editor.....	93
3.24.12	Section Marker Editor.....	94
3.24.13	Smart Panel Editor	94
3.24.14	Stick Editor (v11.1 onwards only) – previously Member Editor	94
3.24.15	Stud Editor.....	94
3.24.16	Tool Action Editor.....	95
3.24.17	Truss Editor.....	95
3.25	MV – Move View.....	98
3.26	QT – Quick Text Input.....	98
3.27	REF – Reference Point Input	99
3.28	RESETALL – Reset Registry.....	100
3.29	REV – Revision Cloud.....	101
3.30	SECT – Section Properties and Capacities	101
3.31	SETREF – Set 3D Marker in Model Space	101
3.32	SHOW – Show Start End of Entities and Show Engineering Failures	102
3.33	SL – Code Support Line.....	103
3.34	SN – Cursor Snap Angle at 45°	103
3.35	SP – Spool Print.....	103

3.36	SS – Steel Profiles.....	104
3.37	TCNC – Text/Lines to CNC.....	105
3.38	VER – Software Version	105
4	Exports	108
4.1	ACNC – Common CNC Export	108
4.2	CNC - Common CNC Export.....	108
4.3	IFC - IFC Export.....	108
4.4	PDF - PDF Export	110
4.5	RFY – Machine File Export	111
5	Wall Framing Commands	114
5.1	AB – Auto Brace.....	114
5.2	Defined Door Input Commands	114
5.3	LP - Load Path	115
5.4	PAB - Auto Break Panel.....	116
5.5	PBN - Bath Noggin.....	116
5.6	PBS - Build Studs	116
5.7	PCB - Calculate Bracing.....	117
5.8	PD - Wall Input (Panel Draw).....	119
5.9	PFB - Opening to Fit Brick	120
5.10	PIB - Insert Brace	121
5.11	PLB - Lap Beam	123
5.12	PN - Panel Notch	123
5.13	PPD - Panel Builder.....	125
5.14	PPD - Panel Builder (Silent)	126
5.15	PRA - Rake Panel	126
5.16	PRP – Panel Reaction Plan	126
5.17	PSA - Stud Array Input	127
5.18	PSC - Stud Array Copy.....	129
5.19	PSN - Special Noggin Input.....	129
5.20	PST – Panel Stacks.....	130
5.21	PUA - Update Panels.....	132
5.22	SB - Show Brick.....	132
5.23	SH - Show Heights	133
6	Truss Commands	135

6.1	BG - Box Gutter	135
6.2	CM - Code Member.....	135
6.3	CRL - Create Roof Lines	135
6.4	RCR - Copy Roof	138
6.5	RL - Code Roof Line	139
6.6	RS - Roof Shape Input	140
6.7	TC – Truss Connections.....	143
6.8	TD - Truss Layout Input	144
6.9	TOA - Truss Accessories Report.....	145
6.10	TPL - Add Truss Point Load	145
6.11	TRE - Rebuild Eaves	146
6.12	TS – Solar Panel.....	146
6.13	TTD - Truss Builder	147
6.14	-TTD - Truss Builder (Silent).....	151
6.15	TUA - Update Truss Engineering.....	151
6.16	TUP - Truss Uplift Plan	152
7	Floor Commands	153
7.1	FD - Draw Floor	153
7.2	FR – Floor Recess.....	153
7.3	FSD - Floor Sheet Input	154
7.4	JD - Joist Layout Input.....	154
7.5	JJD - Floor Joist Builder.....	155
7.6	JSV - Floor Section View.....	156
7.7	Under Floor Pier	156
7.8	Under Floor Post	156
8	Smart Panel Commands.....	157
8.1	SC – Smart Ceiling Panel Input	157
8.2	SR – Smart Roof Panel Input	159
8.3	SF – Smart Floor Panel Input.....	159
8.4	SPD – Smart Panel Builder	160
9	Editing Commands	161
9.1	AS - Add Support	161
9.2	BM - Box Member.....	161
9.3	C - Copy Member	162

9.4	IP - Inherit Properties	162
9.5	IW - Insert Web	163
9.6	M - Move.....	164
9.7	MB - Break Member.....	164
9.8	MC - Cut Member	165
9.9	MD – Member Divide	167
9.10	ME - Extend Member	167
9.11	MF - Fillet Member.....	167
9.12	MI - Mirror	168
9.13	MJ - Join Members.....	169
9.14	ML - Lengthen	169
9.15	MO - Offset Member	170
9.16	MP – Match Properties	170
9.17	MR - Reverse Member.....	170
9.18	MU - Update Member (Previously MS – Member Resquare).....	171
9.19	MX - Trim Crossing Members	171
9.20	RF - Reverse Frame.....	172
9.21	SE - Special Erase	172
9.22	STRIP - Strip Entity Property Intelligence	172
10	Dimension Commands	174
10.1	DA - Aligned Dimension	174
10.2	DH - Horizontal Dimension	174
10.3	DL - Line Dimension	174
10.4	DM - Dimension Members	175
10.5	DO - Ordinate Dimension	175
10.6	DV - Vertical Dimension	176
11	Report Commands	178
11.1	JOA – On Page Joist Accessories Report	178
11.2	OR - On Page Summary	178
11.3	POA – On Page Panel Accessories Report.....	179
11.4	POB - On Page Beam Report.....	179
11.5	POO - On Page Opening Report.....	180
11.6	POP - On Page Post Report	180
11.7	POS - On Page Panel Report	180

11.8	RA – On Page Roof Area Report	181
11.9	REP - Report.....	181
11.10	TOA – On Page Truss Accessories Report.....	182
11.11	TOS – On Page Truss Summary	183
11.12	SUM – Report Summary.....	183
12	Viewing Commands	185
12.1	A3D (or 3D) - Full Layout 3D	185
12.2	J3D - Floor Joist 3D	186
12.3	P3D - Panel 3D	187
12.4	R3D – Roof Plane 3D	187
12.5	T3D - Truss 3D	188
12.6	S3D – Smart Panel 3D	188
12.7	TEMPHIDE.....	189
12.8	V - Go to View.....	189
12.9	VM - Make View	190
12.10	VR - Restore View	191
12.11	VV - View Next	191
12.12	VV - Next 3D View.....	191
12.13	VVD – 3D Views.....	192
12.14	X - View Previous	192
12.15	ZZ - Layout/Detailing Space Toggle.....	193
13	Layer Commands	194
13.1	CL - Copy Layer	194
13.2	IL - Isolate Layer	194
13.3	LC - Current Layer.....	194
13.4	LE - Erase Layer.....	195
13.5	LF - Freeze Layer	195
13.6	LS - Show All Layers.....	196
13.7	LT - Toggle Temporary Layer On/Off.....	196
13.8	LX - Add Layer.....	197
13.9	VC - Visual Controls.....	197
14	How To’s (and other general information)	199
14.1	General.....	199
14.1.1	RESETALL.....	199

14.1.2	A3D - Frames Not Lining Up	199
14.1.3	Checklist	199
14.1.4	Command Aliases (Shortcuts) Missing.....	199
14.1.5	Command Bar Missing	199
14.1.6	Copy.....	200
14.1.7	Creating a Custom Border	200
14.1.8	Data File Updates	201
14.1.9	ELEVATIONLINE Command Not Recognised	201
14.1.10	Export.....	202
14.1.10.1	Export As.....	202
14.1.10.2	Nexa Upload.....	202
14.1.10.3	RFY Export.....	202
14.1.10.4	PDF Export.....	202
14.1.10.5	CNC Export	202
14.1.10.6	ACNC Export All.....	202
14.1.10.7	VRML Export	202
14.1.10.8	IFC Export	202
14.1.10.9	STP Export.....	202
14.1.11	Exporting Gridlines to IFC.....	202
14.1.12	File Dialogue Boxes Missing	202
14.1.13	Imperial Measurement Input Method	203
14.1.14	Importing an Architectural Into a Job as a Block.....	203
14.1.15	Importing IFC file into REVIT	203
14.1.16	Labelling Issue.....	204
14.1.17	Menus – How to Resolve Missing Menus	204
14.1.18	Mirroring Jobs ^(New)	205
14.1.19	Move	205
14.1.20	PCB (Calculate Wind) Not Working.....	205
14.1.21	PDF (PDFSPOOL) Bad Fonts	205
14.1.22	PDF (PDFSPOOL) Not Working.....	206
14.1.23	REF – Multiple Reference Marker Placement.....	206
14.1.24	Restoring an 'AutoSave' Drawing.....	206
14.1.25	Scroll Between 3D Views	207
14.1.26	SECTION MARK.....	207
14.1.27	SECTIONLINE Command Not Recognised.....	207
14.1.28	SHOW – Engineering Failures.....	208
14.1.29	STRIP – Strip Entity Property Intelligence.....	208
14.1.30	SUM – Report Summary	208
14.1.31	TEMPHIDE	208
14.1.32	-TTD – Truss Builder (Silent)	208
14.1.33	Using Viewports (Standard IntelliCAD usage not directly related to Steelwise usage)	208
14.1.34	VM – Make View.....	208

14.1.35	X – Previous Zoom	209
14.1.36	Zone Labelling	209
14.1.37	ZZ – Toggle Tabs	210
14.2	Floor Detailing	210
14.2.1	Add or Amend Floor Beams	210
14.2.2	Adjusting Floor Joist Web Spacing	211
14.2.3	Automatically Hide Layout Layers on PPD (PSET – Options)	211
14.2.4	Deep C Floor Joists – Creating RFY File to Send to Rollformer	211
14.2.5	Deep C Floor Joist – Service Hole Engineering	211
14.2.6	Detail Sheet Border Size	212
14.2.7	Floor Member Summary – No Ceiling Batten Material Displayed	213
14.2.8	Move Joist Labels	213
14.2.9	Opening Joist in Detail Space from the Layout	213
14.3	Wall Detailing	213
14.3.1	Add Lintel Plates to a Frame	213
14.3.2	ADD – Beam Heights	213
14.3.3	Check Load Path onto Walls.....	214
14.3.4	Defined Door Input.....	214
14.3.5	Detail Sheet Border Size	214
14.3.6	How to Erase Lintel L Plates and Leave Member Screws	215
14.3.7	Inserting Webs into Wall Frames (IW).....	215
14.3.8	MB vs MC on Raking Walls.....	215
14.3.9	Opening Commands	215
14.3.10	Opening Input by Point	215
14.3.11	Openings – Label Options.....	215
14.3.12	PCB – Panel Calculate Brace	216
14.3.13	Panel Labelling Options (PSET – Options – Labelling Option)	217
14.3.14	Resetting Stud Data.....	217
14.3.15	SB – Show Brick.....	217
14.3.16	SH – Show Heights.....	217
14.3.17	Sill and Head Check.....	217
14.3.18	Stud Design.....	218
14.3.19	Updating a Wall in the Detail Sheet After Making Changes to it in the Layout	219
14.3.20	Wall Girder Loads	219
14.4	Roof Detailing	220
14.4.1	Add or Amend Roof Loads	220
14.4.2	ADD – Truss Members in Detailing Space	220
14.4.3	Adding External Wind Pressure to Truss Bottom Chords	220
14.4.4	Detail Sheet Border Size	221

14.4.5	Gable End Roof Type Truss Locations.....	221
14.4.6	Lengthening and Shortening Trusses Using the Stretch (ST) Command.....	222
14.4.7	Parallel Chord Girder Trusses.....	222
14.4.8	Setting the height of truncated trusses	222
14.4.9	TSET – Truss Spacing Types – Truncated Girder Truss	222
14.4.10	Truss Bottom Chord Restraints.....	222
14.4.11	Truncated Truss Horizontal Chord Restraint Message	223
14.4.12	Truss Labelling.....	223
14.4.13	TS (Truss Solar) – Solar Panel Input.....	224
14.4.14	TTD – Existing detailed trusses not working.....	224
14.4.15	TUP or LP – Blank Screen on Input	224
14.4.16	TUP – Truss Uplift Plan Values.....	224
14.4.17	User Truss Creation	224
14.5	Smart Panels	225
14.5.1	Not Initialized	225
14.5.2	Add an Opening into a Smart Panel	225
14.5.3	Rake (Slope or Pitch) a Smart Panel	225
14.5.4	How to reshape a Smart Panel on the layout:	225
15	Known Issues.....	227
15.1	Resolve Graphics Performance Issue.....	227
15.2	Erratic mouse movement after a new paper space is created and when performing a command.	227
15.3	Aliases not initialising	227
15.4	Post Input Error Message	228
15.5	Smart Panel – ‘Not initialized yet’ Message in Command Bar.....	228
15.6	File Open and Save Dialogue Boxes Missing.....	228
15.7	Hatching Not Being Displayed	228
15.8	BSET Not Working.....	228

1 Introduction

Commands:

Global name:	This command is non-language dependant.
Local name:	This command is language dependant.
Alias:	This is the shortcut key or alias command.
Space:	This is the paper space within which the command is able to be used.

When instructed to, pressing the Enter key, the space bar or right clicking the mouse button actions a command.

2 Setting Commands

2.1 BSET – Border Setup

Commands:

Global name: `_BORDER_SETUP`

Local name: `BORDER_SETUP`

Alias: **BSET**

Space: `Layout Space`

Purpose:

Initial job border setup.

When you first start a new layout, the first thing you must do is set up the drawing sheet borders. One of the main purposes of this is to give the operator an impression of scale. The information that you input into the dialogue box is what appears on your drawing sheet borders. Other items such as the drawing view notation or the current date are software generated.

The sheet size, drawing scale, units of measurement and design codes are all set within the BSET.

This border is not just for looks; it is a vital part of the software's operation. Without borders set up using the BSET command, the software will not work.

Process:

- Type BSET then press enter. This will open the 'Drawing Sheet Setup' dialogue.
- If the ADD command is activated in a blank drawing, the BSET command will be initiated.

Additional Information:

- If at any stage throughout your drawing session you wish to add or remove drawing sheets, just rerun the 'BSET' command again and change the border quantity. All current information will be found and retained.
- Running the BSET command will also reset the menu if necessary.
- The ADD command activates BSET on a new drawing if no borders are present.

Setting Options:

2.1.1 Layouts Tab

2.1.1.1 Client Options:

- Company Name – shown on Layout borders and Detail Sheet borders
- Drafter – only shown on Layout borders
- Job Number - shown on Layout borders and Detail Sheet borders
- Project Name - shown on Layout borders and Detail Sheet borders
- Project Location 1& 2 – only shown on Layout borders
- Quantity – Enter the number of borders required
- Row – Enter the number of rows required for the borders.
 - The limit to borders is 27 sheets.
 - Each border inserted creates a view.
 - These views are numbered '1 to '27' depending on how many borders were created.

- All views are created from left to right going up the page.

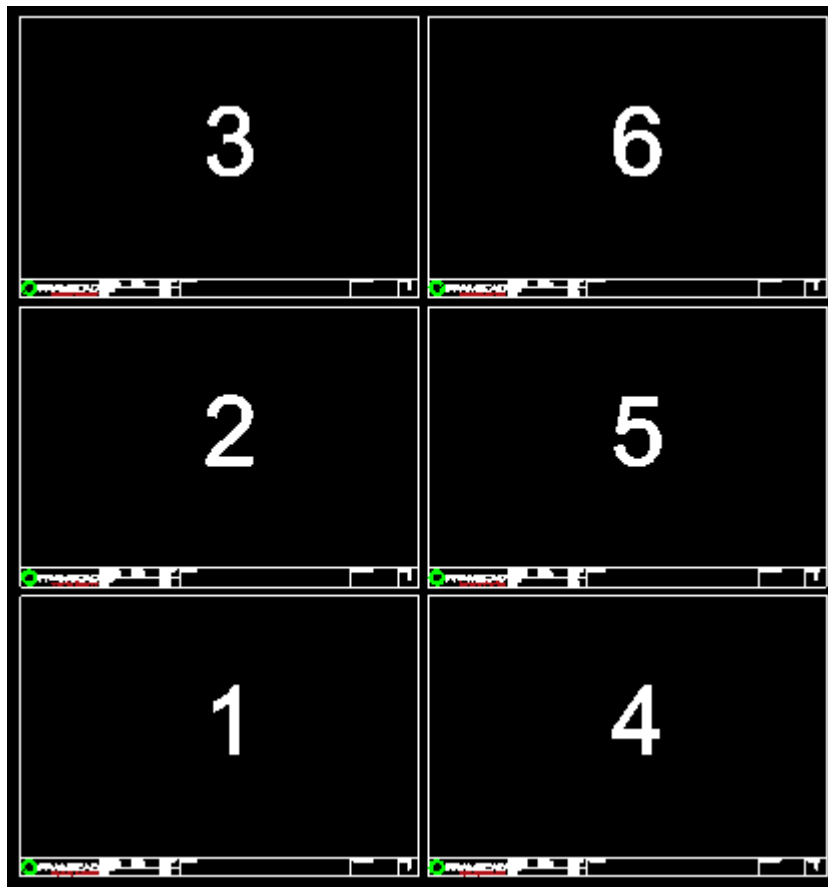

2.1.1.2 Sheet Options

▪ Sheet Size	Selection of the sheet size will depend on the size of the job you are detailing and the scale with which you are working to.
▪ Border Name	The standard border name supplied with the software is 'BR FRAMECAD'. Steelwise also allows for custom borders. In the 'Border Name' field, type in the name of your custom border if applicable. See 'How To Create Custom Borders' in the 'How To's' section.
▪ Border Scale	Set the border scale which best suits the size of the job and the sheet size. Units can be entered as e.g. 50 for 1:50 or alternatively can be entered in as 1:50 using the colon separator. For imperial scales, units can be entered as e.g. 1/8":1'
▪ Units Type	Set the units of measurement to either 'metric units' or 'imperial units'. When 'Imperial Units' is selected, all the fields change to blue for identification. All fields shown in black indicate that metric units are in use. Once a unit type is set, you cannot go back into BSET and change it again.
▪ Text Height	Set the text height which determines the height in mm of the text used on the layout for labels and dimensions.
▪ Detail Sheet Ratio	Sizes the Detailing Space borders relative to metric or imperial sheet sizings.

2.1.2 Engineering Tab

2.1.2.1 Various Tools

Note: These settings are not displayed when running BSET for the first time as they are not applicable until after a job has been created.

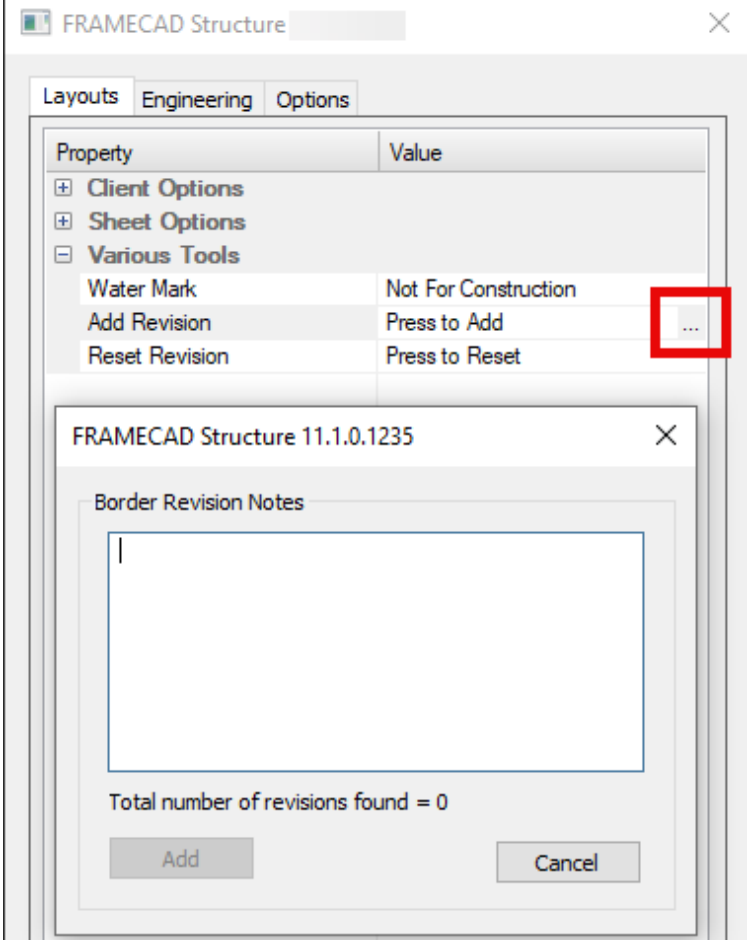
<ul style="list-style-type: none"> Watermark 	<p>Users can input any text which will be applied diagonally across all the layout borders when clicking on the ellipsis button to the right of the text.</p>
<ul style="list-style-type: none"> Add Revision 	<p>Enables the user to add notes whenever revisions are made.</p> <p>To operate:</p> <ul style="list-style-type: none"> - Click on the ellipses button to the right of 'Add Revision'  <p>- A 'Border Revision Notes' dialogue will open allowing you to add any revision notes.</p> <ul style="list-style-type: none"> - Click on 'Add'. - A revision number will be added to the end of the title block and the notes will be placed outside the bottom left corner of the first border (View 1).

2.1.3 Options Tab

2.1.3.1 Design Codes

▪ Loading Design Code	Set the Loading Design Code in accordance with the local building requirements for the job to be detailed.
▪ Steel Design Code	The steel design Code will be automatically updated.
▪ Loading Earthquake Code	
▪ Wind Speed	<p>Change the wind speed to suit the Loading Design Code selected. Wind pressure may be input according to the loading design code requirements.</p> <p>The user can enter in any Wind Pressure by overwriting the Wind Speed with the required value. Note: Only the numerical value is required and may not work if other characters are inserted.</p> <p>Wind Options: Allows to set your terrain and topographic factors in accordance with your loading standards. These Factors are used in the calculation of the wind pressure. This is not applicable to the NASH Design Codes.</p>
▪ Panel Engineering	<p>Unconditional – Full engineering is performed unconditionally on PPD from layout.</p> <p>Automatic – Full engineering is performed initially on PPD, then only if changes are detected.</p> <p>Semi-Automatic – An 'option to update' dialogue is presented on PPD if changes are detected.</p> <p>Manual – Engineering is only performed when the user selects Update Wall Engineering (PUA) in the layout or selects the 'Engineer All' option in the Panel Builder (PPD).</p> <p>Disabled – Engineering fully disabled. Build Wall Studs (PBS) is required to build studs.</p> <p>Note: PPD from wall elevations does not update engineering. Engineering is only updated when using the PPD command from the wall layout.</p>
▪ Brace Engineering	<p>Strength Method - Check for total bracing system strength compared with total demand.</p> <p>Rigid Diaphragm - Check for bracing frame capacity and drift considering rigid diaphragm</p> <p>Disabled – Engineering for bracing fully disabled.</p>
▪ Joist Engineering	Enabled/Disabled
▪ Truss Engineering	Enabled/Disabled
▪ Roof Live Load	

<ul style="list-style-type: none"> ▪ Downgrade Material 	<p>Do Not Downgrade Material – Keeps the material grade to that which is specified in the users data file.</p> <p>Downgrade Material – Downgrades the material grade to suit the selected design code requirements.</p> <p>Note: The material grades may already be downgraded within your data file in which case no change will be noticed regardless of what setting is selected.</p>
--	--

2.1.3.2 Loading Earthquake Code

<ul style="list-style-type: none"> ▪ Loading Earthquake Code 	Required Earthquake Code
---	--------------------------

2.1.3.3 Design Options

<ul style="list-style-type: none"> ▪ Continuity Loads 	Tributary width from internal spans on joists is increased by 25% (i.e. 5/8 of span).
--	---

2.1.3.4 Drawing Options

<ul style="list-style-type: none"> ▪ Post Beam Data File 	Select which beam and post data file is the preference for your region. Options available are BeamsPostsMetric (Australasia), BeamsPostsEU (European metric) and BeamsPostsUS (US imperial).
<ul style="list-style-type: none"> ▪ Aperture Size 	Snap cursor box size
<ul style="list-style-type: none"> ▪ Pick Box Size 	Snap marker box size
<ul style="list-style-type: none"> ▪ Roof Line Colour 	Colour used for the CRL roof line input and RL roof line coding.
<ul style="list-style-type: none"> ▪ Support Line Colour 	Colour used for the SL support line coding.
<ul style="list-style-type: none"> ▪ Roof Line Type 	Linetype used for the CRL roof line input and RL roof line coding.
<ul style="list-style-type: none"> ▪ Hide Change Prompts 	Hides the 'Yes, No, All' options when editing multiple items. Default will be set to 'All'.
<ul style="list-style-type: none"> ▪ Disable Stud Locking Prompts 	Hides the stud locking prompt.
<ul style="list-style-type: none"> ▪ Disable Layout Titles 	Disables the layout titles from being automatically generated, i.e. Roof Truss Layout, Wall Frame Layout, etc.
<ul style="list-style-type: none"> ▪ Use Sheet ID's 	When enabled, a dialogue box option appears when labelling a plan using LA, PLA, TLA, or JLA which allows the user to add a prefix to the layout label.

2.1.3.5 Dimension Options

<ul style="list-style-type: none"> ▪ Linear Dimensions 	Dimension options as applied to the DM (Member Dimension) command.
<ul style="list-style-type: none"> ▪ Ordinate Dimensions 	Dimension options as applied to the DO (Ordinate Dimension) command.

<ul style="list-style-type: none"> Width Options 	<p>This sets whether to show frame widths when dimensioning using the DM (Member Dimension) command.</p> <p>The minimum width indicates whether a dimension is placed on any of the frames that are set to 'True' but are less than the minimum width.</p>
---	--

2.1.3.6 3D (Colour) Options

<p>Allows the user to set colours for Walls, Trusses and Joists as viewed in the Model Space when using the S3D command.</p>	
<ul style="list-style-type: none"> Use Simple Floor 3D 	<p>Use Simple Floor 3D. This option keeps the joists as an 'outline only' in the 3D view even after they have been detailed in JJD. This option is recommended for very large jobs where the 3D joists can look very cluttered and slow down under resourced computers.</p>
<ul style="list-style-type: none"> Use Simple Panel 3D 	<p>Use Simple Panel 3D. This option keeps the wall panels as an 'outline only' in the 3D view even after they have been detailed in PPD. This option is recommended for very large jobs where the 3D wall panels can look very cluttered and slow down under resourced computers.</p>
<ul style="list-style-type: none"> 3D Method (Panels/Trusses/Floors) 	<p>Use Layout Colour - Uses the colours which are applied to the frames in the layout space.</p> <p>Use Detail Colour - Uses the colours which are applied to the members in frames in the detailing space. This colour is determined by the thickness of the material.</p> <p>Use Custom Colour - Allows the user to nominate any colour. See next option.</p>
<ul style="list-style-type: none"> Custom Colour (Panels/Trusses/Floors) 	<p>This is the area where the custom colours are set when the 3D Method is set to 'Use Custom Colour'.</p>

2.1.3.7 Layer Names

<p>Allows the user to change the names of the temporary layers.</p>	
<ul style="list-style-type: none"> Visibility Level (%) 	<p>Indicates the visibility of the temporary layers.</p>

2.1.3.8 Reference Options

<p>Customisation options for the reference markers</p>	
<ul style="list-style-type: none"> Primary Colour 	<p>Colour of the Primary reference marker</p>
<ul style="list-style-type: none"> Secondary Colour 	<p>Colour of the Secondary reference markers</p>
<ul style="list-style-type: none"> Visibility Level (%) 	<p>Visibility of the reference markers</p>
<ul style="list-style-type: none"> Print Reference 	<p>Do you want the Reference Marker to appear on the printed plans?</p>
<ul style="list-style-type: none"> Layer Name 	<p>Default name is "Reference Points"</p>

2.1.3.9 Gridline Options

▪ Gridline Layer	Default name is "Grid Line"
▪ Gridline Text Layer	Default name is "Grid Text"
▪ Gridline Linetype	
▪ Gridline Colour	
▪ Gridline Text Colour	
▪ Gridline Text Factor	
▪ Numeric is Horizontal	Yes = Horizontal gridlines are numeric No = Vertical gridlines are numeric
▪ Prompt for Marker Text	
▪ Show Finishing End Marker	
▪ Show Gridline Line	

2.1.3.10 Export Options

▪ IFC Export Flavour	Options are: Generic, Revit, SAP2000 Generic – Exports anything that is IFC compatible Revit – Doesn't export anything less than 1mm thick as Revit will not accept it SAP2000 – Doesn't export layer names as they will crash SAP
▪ IFC Invert Colours	
▪ Use Clones in XML	Default to "True"
▪ Treat K Brace as Plate	Exports the K Brace as a 'Plate' member type instead of the default 'Stud' member type.
▪ Export Wall Joins in XML	Prints the adjoining end wall labels on the first and last stud
▪ Use Reverse Order XML	True – Exports frames in the reverse order that is shown in a wall frame stack when using the stacking option (PST), i.e. exports frames in order from top to bottom of the stack. False – Exports frames from bottom to top of stack.
▪ Export Header Text in XML	Prints the L-Plate lintel type and quantity on the opening header member
▪ Export Arrows in Wall in XML	Prints wall direction arrows (from left to right) on the bottom plate
▪ Export FIM All to One File	
▪ VRML Swap Y and Z Co-ordinates	

<ul style="list-style-type: none"> ▪ RFY Ordering 	<p>Default – Material exported in order from top left of frame to bottom right.</p> <p>Plates First – Horizontal members</p> <p>Studs First – Vertical members</p> <p>Assembly Priority – For walls, this will export the top plate first; then nogs and studs up to the first opening; then opening material; then nogs and studs to the next opening; etc; then bottom plate.</p>
<ul style="list-style-type: none"> ▪ RFY Export Files 	<p>Single File – All material will be exported in the one RFY file. The rollforming machines Factory software will then filter out any material that exists in the file that is not set up to be run through that machine. This allows for the one file to be used in all machines as long as they are setup to filter.</p> <p>By Section – Different material sections will be split into separate RFY files.</p>

2.1.3.11 Folder Settings Information

Allows the user to modify the folder locations for specific usage or export.

2.1.3.12 Tooling Option

<ul style="list-style-type: none"> ▪ Live Tooling Enabled 	<p>Allows the user to turn off the live tooling to speed up the graphics on very large jobs. This can then be turned on once the job is completed.</p>
<ul style="list-style-type: none"> ▪ Show Graphics in PDF 	<p>Gives the user the option to show/hide the tooling graphics in the PDF output.</p>
<ul style="list-style-type: none"> ▪ Treat K Brace as Plate 	<p>Exports the K Brace as a 'Plate' member type instead of the default 'Stud' member type. Generally used for ST machines if required.</p>
<ul style="list-style-type: none"> ▪ Truss Rails to be Tabbed Over Chords 	<p>False = Rail will run inside chords (chord lips notched out).</p> <p>True = Rail will be tabbed over top chord (rail lips and web notched out).</p>

2.2 JSET - Floor Settings

Commands:

Global name: `_JOIST_SETTINGS`

Local name: `JOIST_SETTINGS`

Alias: **JSET**

Space: Layout and Detailing Space

Purpose:

Floor framing setup form. Floor settings will be applied to the joists created after using the 'JSET' command.

Process:

- Type JSET then right click or press Enter.
- Make any required changes then Save (or Cancel to exit without saving).

Additional Information:

Changing values in the JSET will not affect joists that already exist on plan. To change the settings of existing joists, use the List command 'LI'.

Setting Options:

2.2.1 Layouts Tab

2.2.1.1 Member Information

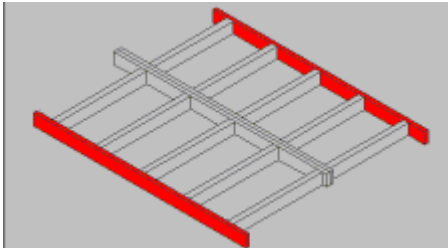
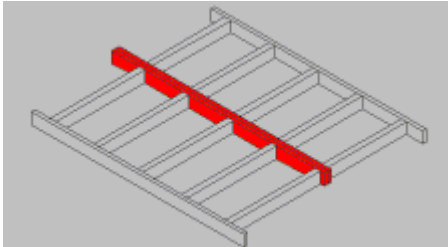
<ul style="list-style-type: none"> System Name 	<p>The system to be used for the joists. After selecting a joist system, all joist settings will be restored to the selected system defaults.</p>
<ul style="list-style-type: none"> Model Name 	<p>Sub System to be used. To find out specifically what the sub system is, you will need to talk with your systems administrator.</p>
<ul style="list-style-type: none"> End Bearer Type 	<p>Type of end bearer to be used. An 'End Bearer' is a member that carries terminating joists. If you do not wish to use any 'End Bearer', select 'None' from the drop-down box.</p> <p>All other joist types below this item will be populated with the same selection.</p> <p>Selecting 'None' will not affect other joists selections.</p> 
<ul style="list-style-type: none"> Int Bearer Type 	<p>Type of Internal bearer to be used. An 'Internal Bearer' is a member that usually carries joists on each side. If you do not wish to use any 'Side Bearer', select 'None' from the drop-down box.</p> <p>All other joist types below this item will be populated with the same selection. Joist types above this item will remain unaffected.</p> <p>Selecting 'None' will not affect other joists selections.</p> 

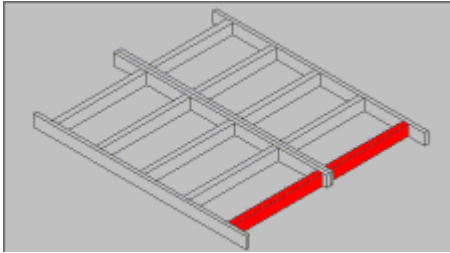
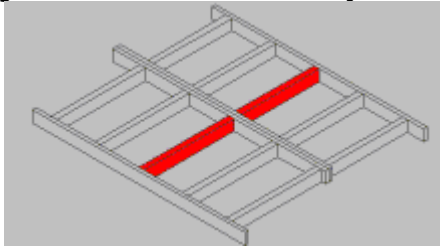
<ul style="list-style-type: none"> ▪ Side Bearer Type 	<p>Type of side bearer to be used. A 'Side Bearer' is a member that usually does not carry joints. If you do not wish to use any 'Side Bearer', select 'None' from the drop-down box.</p> <p>All other joist types below this item will be populated with the same selection. Joist types above this item will remain unaffected.</p> <p>Selecting 'None' will not affect other joists selections.</p> 
<ul style="list-style-type: none"> ▪ Joist Type 	<p>Type of joist to be used.</p> <p>Joist types above this item will remain unaffected.</p> <ul style="list-style-type: none"> - Selecting 'None' will not affect other joists selections. 
<ul style="list-style-type: none"> ▪ Member Height Override 	<p>Overrides the default joist Depth. Does not override the height of deep ce joists.</p>

2.2.1.2 Layout Information

<ul style="list-style-type: none"> ▪ Joist Spacing 	<p>This sets the maximum spacing of the joist. It is defined as the distance from the centre of one joist to the next.</p>
<ul style="list-style-type: none"> ▪ Int Bearer Spacing 	<p>Maximum spacing of the Internal Bearers.</p>
<ul style="list-style-type: none"> ▪ Ceiling Batten Spacing 	<p>Spacing of the ceiling Batten along the bottom chord of the joists. Used for bottom chord restraint engineering calculations.</p>
<ul style="list-style-type: none"> ▪ Reduced Level 	<p>This is the height of the floor system and is measured to the top chord of the joists. This value is critical when joists layouts are detailed in association with the wall framing. The value must be less than the joist depth plus or minus 100mm of the wall height before loads are able to be transferred.</p>
<ul style="list-style-type: none"> ▪ Bearers Method 	

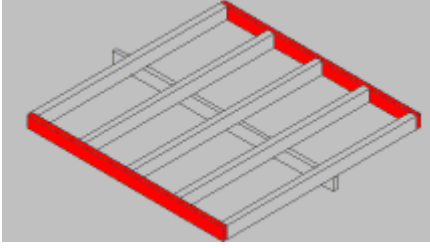
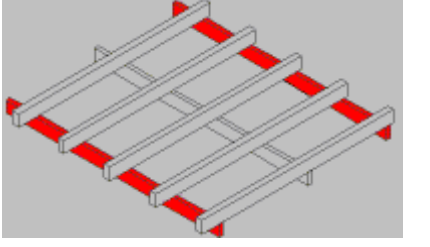
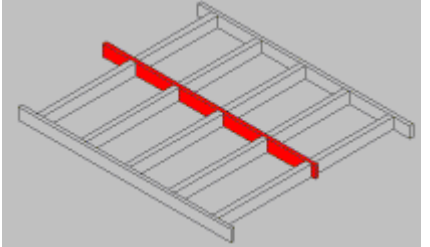
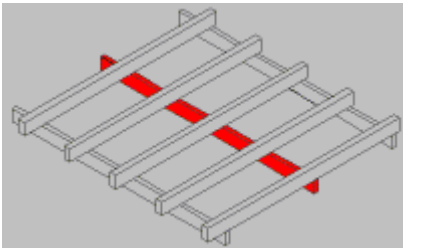
<ul style="list-style-type: none"> • Bearers Method 	<p>Bearers Inline: The 'End Bearers' will be located inline.</p>  <p>Bearers Under: The 'End Bearers' will be located under the joist.</p>  <ul style="list-style-type: none"> ▪ Blocking: The 'End Bearers' will be inline and split up as short blocking members between the ends of the joists.
<ul style="list-style-type: none"> ▪ Inline Internal Bearers 	<ul style="list-style-type: none"> ▪ True: The 'Internal Bearers' will be located inline  <ul style="list-style-type: none"> ▪ False: The 'Internal Bearers' will be located under the joist. 

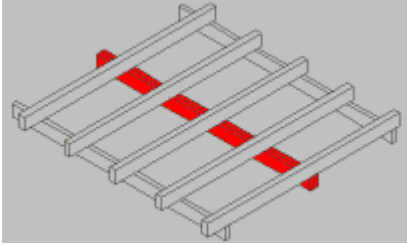
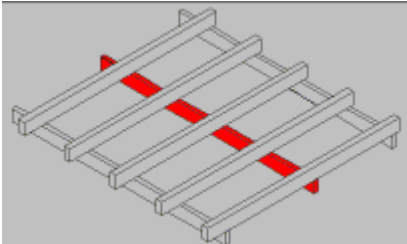
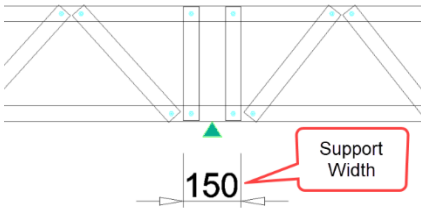
<ul style="list-style-type: none"> Double Int Bearers 	<ul style="list-style-type: none"> True: a set of 2 'Internal Bearers' will be used.  <ul style="list-style-type: none"> False: A Single 'Internal Bearer' will be used. 
<ul style="list-style-type: none"> Oncoming Web Align 	<p>Vertical webs will be placed to align with any oncoming members for fixing purposes.</p>
<ul style="list-style-type: none"> Double Webs to Supports 	<p>Places two vertical members inside each edge of a support line of a pre-defined width.</p>  <p>To apply a width to a support line, list (LI) the support line and change the 'Support Line Data' parameters to suit.</p>

2.2.1.3 Applied Loads

<ul style="list-style-type: none"> Dead Load (unit) 	<p>Dead Load from the floor which will be applied to the joist. The unit is KPa for metric, and psf for imperial.</p>
<ul style="list-style-type: none"> Live Load (unit) 	<p>Live Load from the floor which will be applied to joist. The unit is KPa for metric, and psf for imperial.</p>
<ul style="list-style-type: none"> Ceiling Load (unit) 	<p>Dead Load from the ceiling which will be applied to the bottom chord of the truss. The unit is KPa for metric, and psf for imperial.</p>
<ul style="list-style-type: none"> Snow Load (unit) 	<p>Snow load on the joist. The unit is KPa for metric, and psf for imperial.</p>
<ul style="list-style-type: none"> Design Point Load (unit) 	<p>Joist Point Load. The unit is kN for metric, and kip for imperial.</p>

2.2.1.4 Ceiling Battens Information

Used for quantity take-off purposes only	
▪ First Ceiling Batten	Section profile to be used for the first ceiling batten
▪ Next Ceiling Batten	Section profile to be used for all subsequent ceiling battens
▪ First Batten Length	
▪ First Batten Lap	
▪ Next Batten Length	
▪ Next Batten Lap	
▪ End Screw Type	
▪ End Screw Frequency	
▪ Int Screw Type	
▪ Int Screws per Crossing	

2.2.1.5 Creation Options

▪ Auto Cutting List	<ul style="list-style-type: none"> ▪ True: Automatically include the floor member summary in the floor layout view if joists are labelled. ▪ False: Does not Automatically include the floor member summary in the floor layout view.
▪ Auto Label Members	<ul style="list-style-type: none"> ▪ True: Label joist automatically ▪ False: Does not label joist automatically
▪ Preserve Floor Outline	<ul style="list-style-type: none"> ▪ True: Preserve the floor outlines ▪ False: Automatically delete the floor outlines
▪ Auto Floor Sheet Layout	<ul style="list-style-type: none"> ▪ True: Automatically inserts the Floor sheeting layout in the selected location using the sheeting settings from the JSET 'Others' Tab. The Floor Sheeting layout can also be manually inserted using the 'FSD' command. ▪ False: Does not automatically insert the Floor sheeting layout

2.2.1.6 Report Options

▪ Include Members	
▪ Include Connection Brackets	
▪ Include Connection Fixings	
▪ Include Weight	
▪ Include Battens	
▪ Include Batten Fixing	

2.2.1.7 Labelling Options Information

▪ End Bearer Prefix	Choose Prefix for End Bearer label. Example: E
▪ Side Bearer Prefix	Choose Prefix for Side Bearer label. Example: S
▪ Int Bearer Prefix	Choose Prefix for Internal Bearer label. Example: I
▪ Joist Prefix	Choose Prefix for Joist label. Example: J
▪ Include Joints	
▪ Include Supports	
▪ Include Service Holes	
▪ Include Smart Ends	
▪ Use Continuous Numbers	
▪ Collect Common Members	

2.2.2 Options Tab

Sheet Information	
Under Floor Information	
Rough In Options	
Detail Sheet Option	

2.3 PSET - Panel Settings

Commands:

Global name: `_PANEL_SETTINGS`

Local name: `PANEL_SETTINGS`

Alias: **PSET**

Space: Layout and Detailing Space Purpose:

Wall framing setup form. Settings will be applied to the panel created after using the 'PSET' command.

Process:

- Type PSET then press Enter.
- Make any required changes then Save (or Cancel to exit without saving).
- Additional Information:

- Changing values in PSET will not affect walls/beams that already exist on the plan. To change the settings of existing walls or beams, use the List command (LI) and select the walls you wish to edit.
- The PSET dialogue box can also be accessed from the PD (Panel Draw) command by pressing Enter again after activating PD.
- Most of the options in this dialogue are basically pre-set options and can be changed at a later stage if desired with the LI (List) command. However, there are two options that cannot be changed at a later stage and MUST be correct at the time of drawing. These options are 'Drafting Width' and 'Offset Distance'.
- After changes have been made to the settings, you can save these for future use by holding down the 'ALT' key and clicking on 'System Name*'. These settings will be saved to a user defined data file which can be updated at any stage by repeating the above procedure.
- If you wish to have different settings applied to different framing models, then hold down the 'ALT' key and click on 'Current Model*'.

Setting Options:

2.3.1 Panels Tab

2.3.1.1 Panel Information

<ul style="list-style-type: none"> ▪ System Name 	<p>The system to be used for the wall panels. You may mix systems within a single job.</p>
<ul style="list-style-type: none"> ▪ Current Model 	<p>This is the sub system or member profile requirements for the job. If a user has a list of commonly used profile sizes, this list can be modified to suit by creating a ticket and requesting a custom data file through the 'FRAMECAD Care' or 'My Support' section in https://my.framecad.com</p>

2.3.1.2 Panel Widths and Lengths

<ul style="list-style-type: none"> ▪ Drafting Width 	<p>Sets the width of the wall frame as drawn. This is purely for visual plan purposes and dimensioning purposes. Any adjoining walls will ignore this width and automatically extend to suit the 'Actual Width'.</p>
<ul style="list-style-type: none"> ▪ Actual Width 	<p>The actual width of the frame. This is generally the width of the standard steel section profile being used. The software will automatically adjust the length of adjoining frames to cater for the actual width.</p> <p>If this width is changed to match the Drafting Width, any adjoining walls will be shorter or longer by the difference between the width nominated and the steel profile actual width.</p>
<ul style="list-style-type: none"> ▪ Maximum Length 	<p>Stores the desired maximum length of the wall panels. This value is later used by the 'IC' command (Integrity Check) to warn users of frames of excessive length. See 'Additional Information' above to change settings for existing walls.</p>
<ul style="list-style-type: none"> ▪ Offset Distance 	<p>This will offset the wall frame by this distance in the direction of the side selected. If one side or another is not selected, then the frame will be drawn using the center line method and no offset will occur. This setting is generally used when tracing over a plan where the frame width drawn includes claddings, etc.</p>

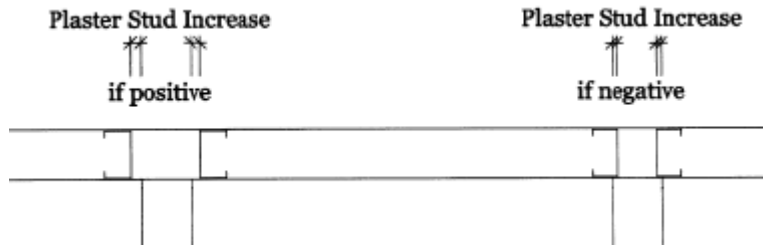
<ul style="list-style-type: none"> Plaster Stud 1 	<p>The distance by which the plaster stud will be offset from the face of the intersecting wall. To move outwards, use a positive number, to move inwards, use a negative number. This option is generally used to allow for wall lining thicknesses.</p> 
<ul style="list-style-type: none"> Plaster Stud 2 	<p>The distance by which the plaster stud will be offset from the face of the intersecting wall when using the command 'PAB' (Panel Auto Break). To move outwards, use a positive number, to move inwards, use a negative number.</p>
<ul style="list-style-type: none"> Truss Location Tolerance 	<p>Distance within which a stud will be placed under all trusses landing on the wall frame. If another stud is found within this distance, then no stud will be placed under that truss. If no stud is found within this distance, then a stud will automatically be placed under the truss only if required by the engineering.</p> <p>This field overrides the automatic stud placement in such a way that only a higher level of structural integrity is provided.</p>
<ul style="list-style-type: none"> Joist Location Tolerance 	<p>Distance within which a stud will be placed under all joist landing on the wall frame. If another stud is found within this distance, then no stud will be placed under that joist. If no stud is found within this distance, then a stud will automatically be placed under the joist only if required by the engineering.</p> <p>This field overrides the automatic stud placement in such a way that only a higher level of structural integrity is provided.</p>
<ul style="list-style-type: none"> Add Service Holes to Top Plate 	<p>Includes or excludes service holes to the top plate.</p>
<ul style="list-style-type: none"> Hide Truss Holes to Top Plate 	<p>Includes or excludes truss locator (Web) holes to the top plate.</p>
<ul style="list-style-type: none"> Ribbon Plate Type 	<p>Type of ribbon plate configuration used if required.</p>
<ul style="list-style-type: none"> Ribbon Plate Required 	<p>Includes or excludes ribbon plates.</p>

2.3.1.3 Opening Options

<ul style="list-style-type: none"> Opening Head Style 	<p>Lintel Head - Opening header which uses L-Plate lintels fixed to vertical webs. It can be reinforced with 1x L-plate or 2x L-plates fixed at the top of the frame. In cases where the engineering status of the Lintel Head has failed with the reinforced L-plates, the software will automatically add diagonal webs to reinforce the Header.</p> <p>Webbed Head - Opening header which uses diagonal webs. The Webbed Head can be reinforced with 1x L-plate or 2x L-plates fixed at the top of the opening. The web pattern can be changed by listing (LI) the opening.</p> <p>Beam Head - Opening header which uses a Deep Cee member. The Deep Cee profile can be changed by listing (LI) the opening.</p>
--	--

<ul style="list-style-type: none"> ▪ LB Web to Openings 	Minimum width for openings without diagonal webs in Load Bearing walls. Openings less than this width will not have diagonal webs added.
<ul style="list-style-type: none"> ▪ NLB Web to Openings 	Maximum width for openings without diagonal webs in Non-Load Bearing walls. Opening above this width will have webs added even if the software engineering analysis says they are not required. When set to zero, no maximum width will be considered.

2.3.1.4 Integrity Check Option

The various CHECK options can be enabled or disabled in the Integrity Check Options by changing to True or False.	
<ul style="list-style-type: none"> ▪ Reference Points 	True: Report if panel is missing a reference point
<ul style="list-style-type: none"> ▪ Panel not coded 	True: Report panels that are not coded
<ul style="list-style-type: none"> ▪ Panel Labelling 	True: Report panels that are not labelled
<ul style="list-style-type: none"> ▪ Panel Length Shortage 	True: Report panels that are short
<ul style="list-style-type: none"> ▪ Panel Overlaps 	True: Report panels that are overlapping
<ul style="list-style-type: none"> ▪ Maximum Panel Lengths 	True: Report panels that are exceeding the maximum length
<ul style="list-style-type: none"> ▪ Transport Limits 	True: Report panels that are exceeding transport limitations
<ul style="list-style-type: none"> ▪ Openings Across Joins 	True: Report openings that are spread over two wall panels
<ul style="list-style-type: none"> ▪ Bracing Over Openings 	True: Report braces that are over openings
<ul style="list-style-type: none"> ▪ Panel Imposed Loads 	True: Report panels that are found with no Dead Loads
<ul style="list-style-type: none"> ▪ Duplicate Labels 	True: Report panels that have the same label
<ul style="list-style-type: none"> ▪ Show Items Not Detailed 	True: Report panels that have not been detailed
<ul style="list-style-type: none"> ▪ Select All 	
<ul style="list-style-type: none"> ▪ Clear All 	

2.3.1.5 Brace Panel Information

<ul style="list-style-type: none"> ▪ Brace Type 	Select the bracing type required. The bracing type can also be changed when using the command 'PIB' (Panel Insert Brace).
<ul style="list-style-type: none"> ▪ Stud Bays or Strap Angle 	Number of Stud Bays a K Brace is allowed to go over. Strap angle to be maintained.

2.3.1.6 Panel Options

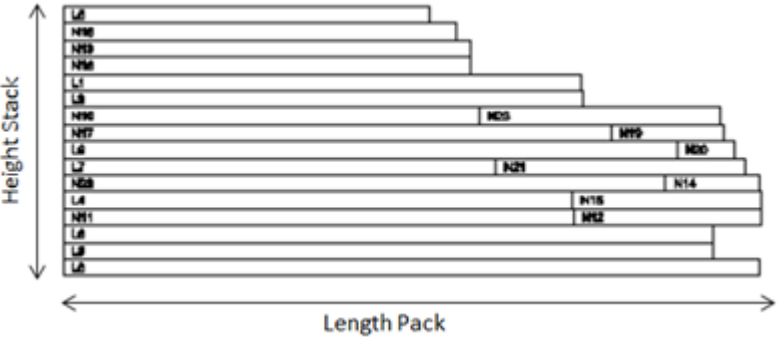

Sets the brace type which will most commonly be used and the number of stud bays to limit the input to. These options can also be changed when using the PIB (Brace Input) command.

<ul style="list-style-type: none"> Use LB Clusters 	<p>True: Cluster stud (or plaster stud) will be added on Load Bearing wall intersections</p>
<ul style="list-style-type: none"> Use ST Clusters 	<p>True: Cluster stud (or plaster stud) will be added on Structural wall intersections</p>
<ul style="list-style-type: none"> Use NLB Cluster 	<p>True: Cluster stud (or plaster stud) will be added on Non-Load Bearing wall intersections</p>
<ul style="list-style-type: none"> OH&S Weight Limit 	<p>Displays a warning on the elevation sheet if the panel weight exceeds this value.</p>
<p>Panel Stacking Options Settings the 'PST' command</p> 	
<ul style="list-style-type: none"> Max Height stack 	<p>Maximum height of the pack for transportation purposes</p>
<ul style="list-style-type: none"> Use Height Method 	<p>True: The Maximum stack Height will govern the number of stacks required False: The user will be asked the number of stack required and the maximum height stack will be ignored.</p>
<ul style="list-style-type: none"> Separate Different Models 	<p>Separates out different modes into separate stacks.</p>

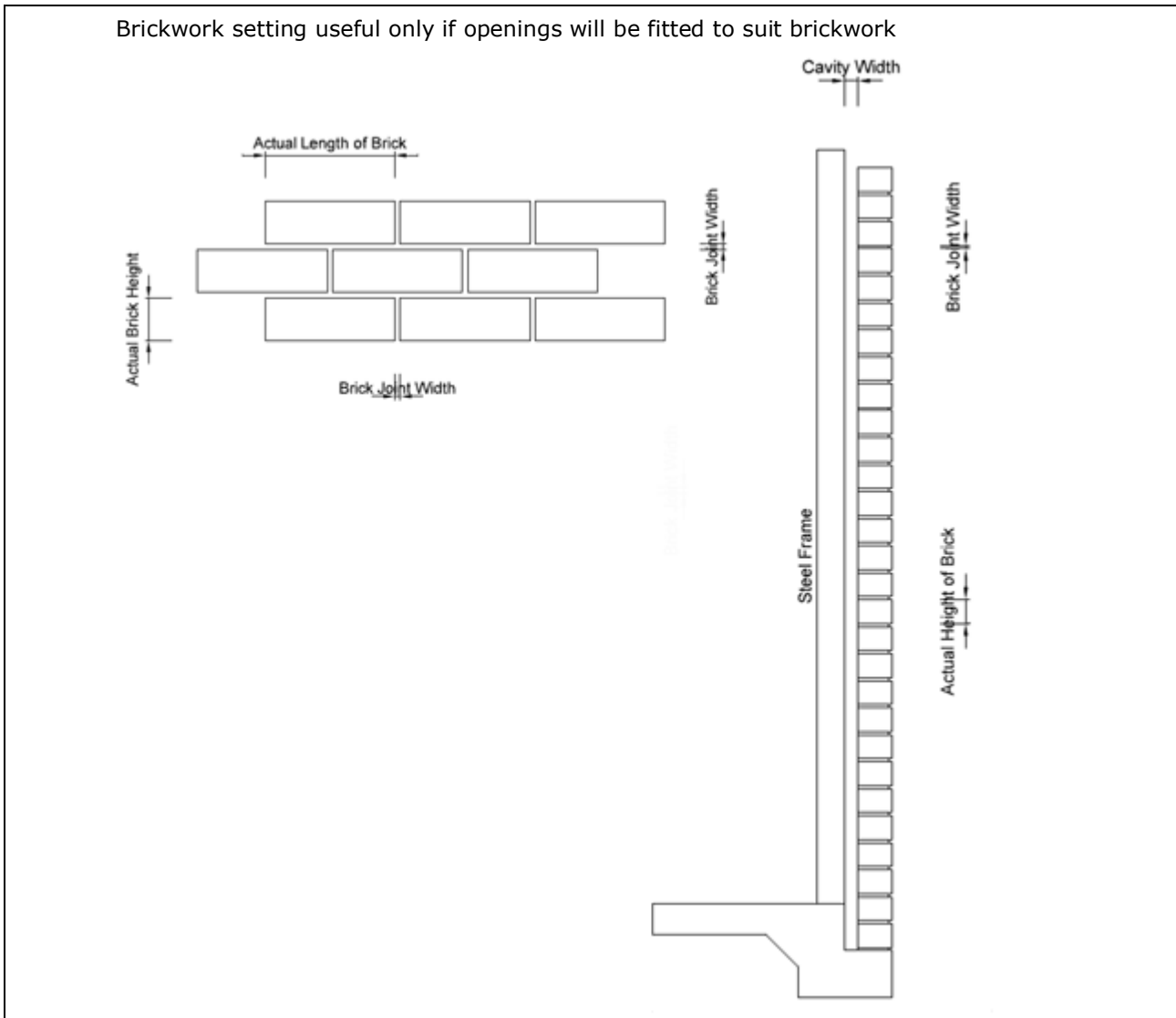
2.3.1.7 Brick Gauge Options

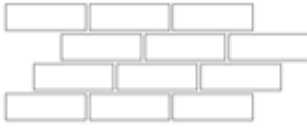

▪ Actual Length of Brick	Horizontal length of bricks
▪ Actual Depth of Brick	Depth of the brickwork
▪ Actual Height of Bricks	Vertical Height of bricks
▪ Brick Joint Width	Vertical and horizontal gap between bricks, also known as perpend
▪ Cavity Width	Gap between the back of the brickwork and the wall frame

Brickwork Bond Qty	<p>Brick Bond Type. Normally a brick bond type is either 2 for standard brickwork or 3 for modular brick work</p> <div style="display: flex; justify-content: space-around; align-items: center;"> <div style="text-align: center;">  <p>Example if 'Bond Qty' = 2</p> </div> <div style="text-align: center;">  <p>Example if 'Bond Qty' = 3</p> </div> <div style="text-align: center;">  <p>Example if 'Bond Qty' = 4</p> </div> </div>
-----------------------	--

2.3.2 Openings Tab

2.3.2.1 Common Setting Information

▪ Window Library	This is the opening library file to be used. This applies to the 'AW', 'AD', 'TW', and 'TD' commands only.
▪ Window/Door/Robe Auto Offset	This is the side offset distance that will be used when the 'Auto' insert option is used.
▪ Floating Stud Gap	This is an additional clearance in the width that will be allowed for to use floating studs.
▪ Prompt Width First	Set to TRUE to input width first.

2.3.3 Options Tab

2.3.3.1 Ceiling Panel Options Information

▪ Ceiling System	
▪ Current Model	
▪ Maximum Length	
▪	

2.3.3.2 Stud Array Options Information

▪ Material Type	Select material from the dropdown box if a specific material is required otherwise, leaving set to 'Auto' will use whatever material that has been set by the data file for the default system.
▪ Starting Position	This is the location of the first stud that will be inserted. This option is only available when using the 'By Points' insert option.
▪ Stud Spacing	This is the stud to stud spacing, i.e. the distance from the centre of one stud to the centre of the next stud.
▪ Stud Type	This is the stud arrangement of the studs that will be used. Boxed studs will only be shown if it is enabled in the data file. If using boxed studs, please ensure that the material is boxable, as the software will not check for this.

<ul style="list-style-type: none"> ▪ Stud Insert Type 	<p>Allows the user to select either 'Single Insert', 'By Points' or 'By Entities' methods.</p> <p>With the 'Single Insert', the user selects a single point anywhere along a wall frame, the cursor snap mode remains set at end point or intersection. The stud is inserted in the wall with the insertion point being dictated by the 'Stud Setout' option.</p> <p>With the 'By Entities' method, the user is prompted to select a wall entity, then for a starting point. Set out is calculated from this point.</p> <p>With the 'By Points' method, the studs are set out from the first point selected through to the second point selected. This selection can be applied along multiple walls.</p>
<ul style="list-style-type: none"> ▪ Opening Option 	

2.3.3.3 Notch Settings

Places a notch in the bottom corner of a frame.	
<ul style="list-style-type: none"> ▪ Notch Height 	Height of notch from the bottom of the frame.
<ul style="list-style-type: none"> ▪ Notch Width 	<p>Width of the notch from one end of the frame or the other.</p> <p>A positive value places the notch at the left-hand end of the frame and a negative value places the notch at the right-hand end of the frame.</p>

2.3.3.4 Labelling Option Information

<ul style="list-style-type: none"> ▪ Labelling Method 	<p>Traditional Method - Labels all walls from the top left-hand corner of the framing layout in a diagonal direction towards the bottom right.</p> <p>Directional Method - Labels the external walls anti-clockwise from the corner of the layout as indicated by the 'Labelling Direction' (walls may be labelled in a clockwise direction if the start walls are lapped differently). Internal walls are then labelled from the same corner then towards the opposite corner of the layout.</p>
<ul style="list-style-type: none"> ▪ Labelling Direction 	This is the starting corner for 'Directional Method' labelling.
<ul style="list-style-type: none"> ▪ Use Continuous Numbering 	<p>If set to TRUE, then the wall labelling will start at 1 and continue for all the walls regardless of the wall type.</p> <p>If set to FALSE, then the numbering will restart from 1 for each wall type.</p>
<ul style="list-style-type: none"> ▪ Restart Zone Numbering 	<p>If set to TRUE, then the wall zone labelling will restart at 1 for each zone.</p> <p>If set to FALSE, then the numbering will be continuous through all zones.</p>
<ul style="list-style-type: none"> ▪ Ignore Overlay Checks 	Checks to see if an existing label or intersecting wall is present and moves the label for clarity. This can slow down the labelling process on large jobs.
<ul style="list-style-type: none"> ▪ Label Prefix 	
<ul style="list-style-type: none"> ▪ Label Marker 	
<ul style="list-style-type: none"> ▪ Disable Sorting 	If sorting is disabled then walls can be labelled in the order they are selected.

<ul style="list-style-type: none"> ▪ Use Location Marker 	When enabled, wall labels will have a suffix added to indicate whether they are internal or external, e.g. LE1 = Loadbearing External 1
---	---

2.3.3.5 Folder Settings Information

--	--

2.3.3.6 Detail Sheet Options

--	--

2.4 TSET - Truss Settings

Commands:

Global name: `_TRUSS_SETTINGS`

Local name: `TRUSS_SETTINGS`

Alias: **TSET**

Space: Layout and Detailing Space

Purpose:

Truss framing setup form. Settings will be applied to the trusses created after using the 'TSET' command.

Process:

- Type TSET then right click or press Enter.
- Make any required changes then Save (or Cancel to exit without saving).

Additional Information:

Note: Changing values in the TSET will not affect trusses that already exist on plan. To change the settings of existing trusses, use the List command (LI) and select the trusses you wish to edit.

Setting Options:

2.4.1 Layout Tab

2.4.1.1 Layout Options

<ul style="list-style-type: none"> ▪ System Name 	<p>The system to be used for the trusses. After selecting a truss system, all truss settings will be restored to the selected system defaults, however the roof load and truss pitch will remain unchanged.</p> <p>To save all settings for future jobs, left click on the System* wording while hold down the Alt key. Doing this will create a user defined data file containing this information that will take precedence over the standard data file.</p>
<ul style="list-style-type: none"> ▪ Model Name 	<p>Indicates available profile size and section orientation.</p> <p>LE System: Inline trusses</p> <p>LC System: Back-to-Back trusses</p>

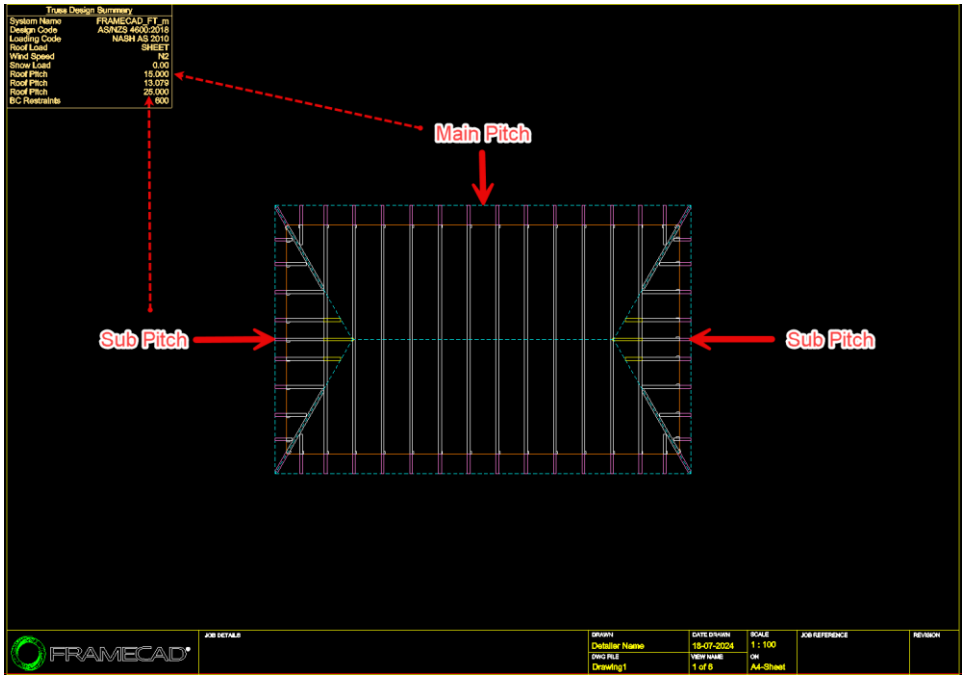
<ul style="list-style-type: none"> Roof Load 	<p>SHEET = Lightweight roofing material; TILE = Heavyweight roofing material.</p> <p>To add or amend a load, left click on the Roof Load* wording while holding down the Alt key. Doing this will create a user defined data file containing this information that will take precedence over the standard data file.</p>
<ul style="list-style-type: none"> Roof Pitch 	<p>This is the angle of the roof slope defined in decimal degrees, rise:run notation or a percentage.</p> <p>If you wish to define the roof pitch by rise over run in degrees, then click on the ellipsis button to the right of this field. Enter in the run and rise values (the pitch field will automatically update) then click on 'Transfer' to place the 'degrees' value into the main dialogues pitch field.</p>
<ul style="list-style-type: none"> Sub Pitch 	<p>This is the sub pitch or secondary pitch. This pitch is applied to the hip or valley ends of a roof block.</p> 
<ul style="list-style-type: none"> Wind Speed 	<p>The available wind speed options will vary according to the Design Code that is set in the Roof Loads section.</p>
<ul style="list-style-type: none"> Ground Snow Load 	<p>This is the amount of snow load that will be used for the design of the roof trusses. This load is measured in kPa for metric, and psf for imperial.</p>
<ul style="list-style-type: none"> Reduced Level 	<p>This is the level of the roof in relation to the walls below and is measured to the bottom chord of the trusses. This value is critical when truss layouts are detailed in association with the wall framing. The value must be less than plus or minus 100mm of the wall height before loads are able to be transferred.</p>

▪ Hip Method

Half Truss - Half trusses (or jack trusses) are placed at the hip ends attached to the last truncated truss with the top chord extending up to the hip line.

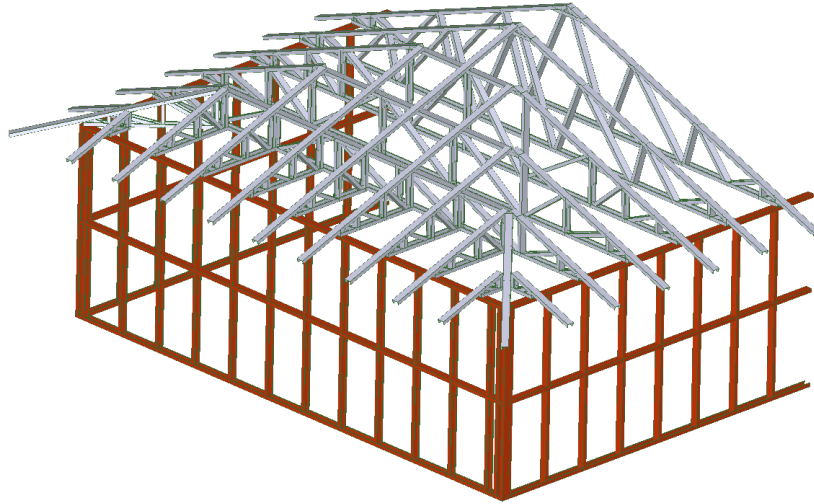

Rafters - Rafters are placed at the hip ends. The truncated truss heights are dropped to suit the rafters web width.

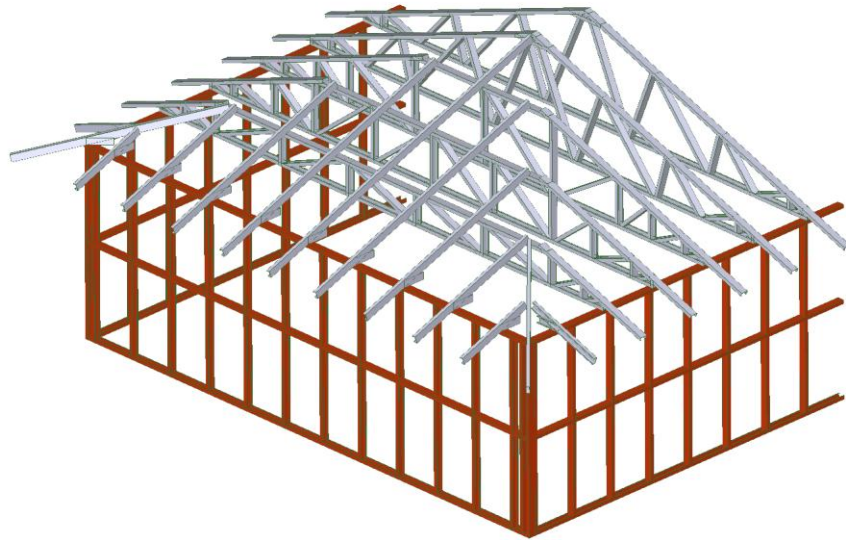

Panel Jacks

These are roof panels that are placed over the horizontal top chords of the hip end truncated trusses, thus, replacing the hip end jack truss top chord extensions.

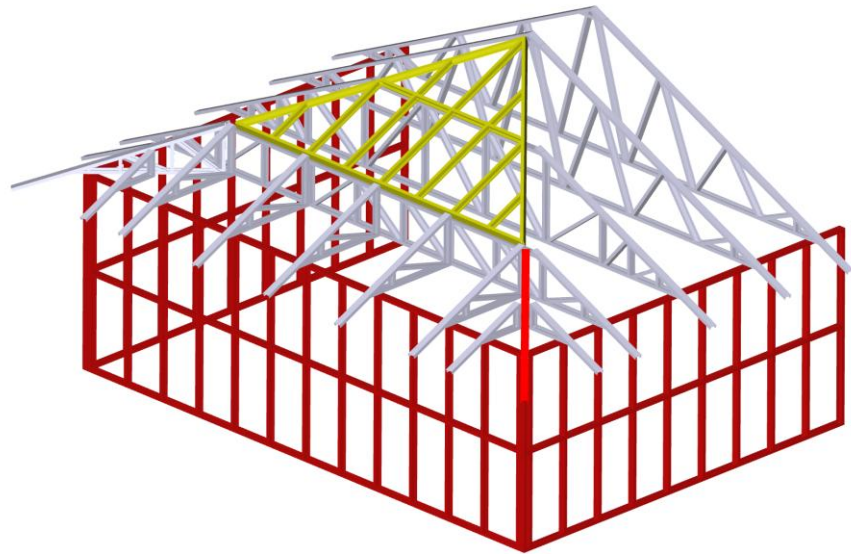

The panel starts from the first truncated truss and finishes at the hip apex.

Note: The top front edge of the roof panel sits flush with the front face of the truncated truss.

The first truncated truss is raised slightly to allow for the bottom edge of the roof panel to sit directly on it based on the roof pitch.

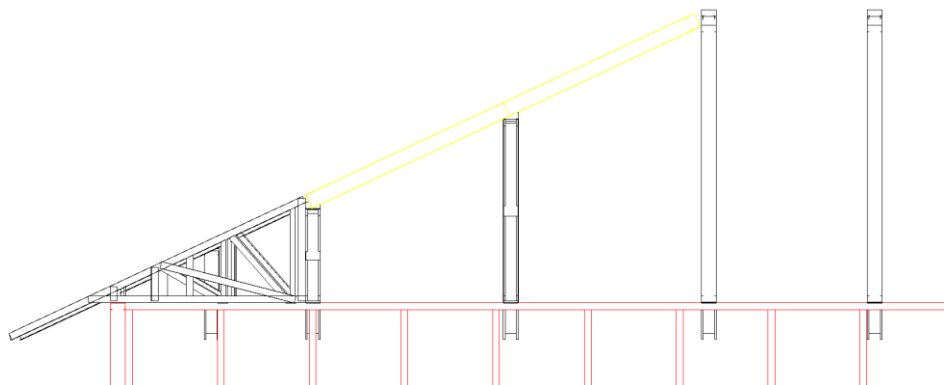

The roof panel model and other options can be set in the 'Roof Panel Options' in TSET.

Note that panel jacks are 'Smart Panels', therefore they must be labelled, built and 3D generated using the associated smart panel commands, i.e. PLA, SPD and S3D respectively.

During onsite erection, the front edge of the roof panel must line up with the face of the truncated truss.

▪ Overhang Method

Overhang Frames - Gable frames are automatically placed. The height of the gable end truss is lowered by the section depth set in the model to allow the top of the gable frame to sit flush with the roof plane and cantilever out over the gable truss. The overhang distance is set by the roof lines.

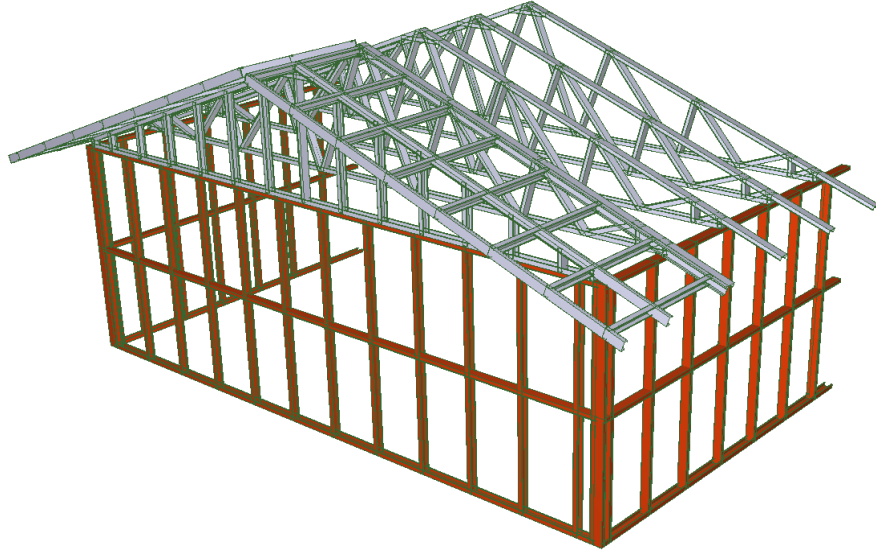

Outriggers - Gable verge outriggers are placed on the plan. These members are detailed to sit on the first truss into the building, over the gable truss, then cantilever out to the overhang line and have a vertical piece attached to the end to attach the barge board to. They are intended to be fixed under the roof battens so that every 1st, 2nd or 3rd batten (depending on the batten spacing and the outrigger spacing) sits inside the outrigger.



None - No gable end members or framing is allowed for.

▪ Eave Options

Standard Eave – The top chord of the truss is extended past the heel of the truss out to the roof line (RL)

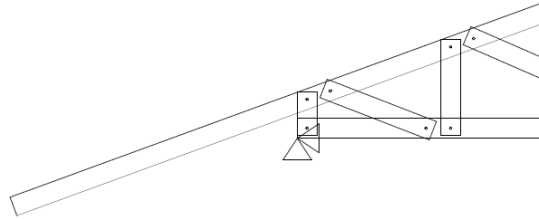

Extended Eave – This option extends the bottom chord out past the heel location to meet the top chord. This option effectively cuts down the cantilever distance of the top chord overhang.

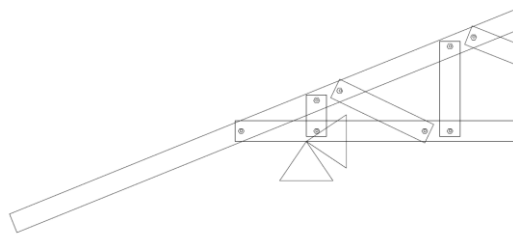

Separate Eave – This option removes the top chord past the heel point. A rafter member in the deep axis is added to the layout separately which is attached to the side of the truss on site to create the overhang.

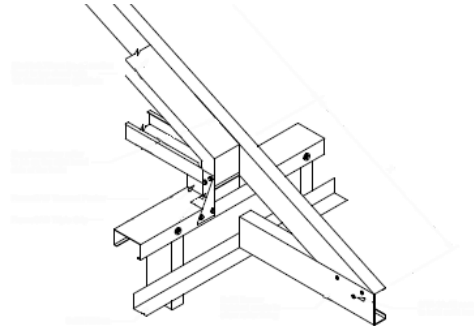

Reinforced Eave – Standard eave reinforced with a C section on the deep axis.

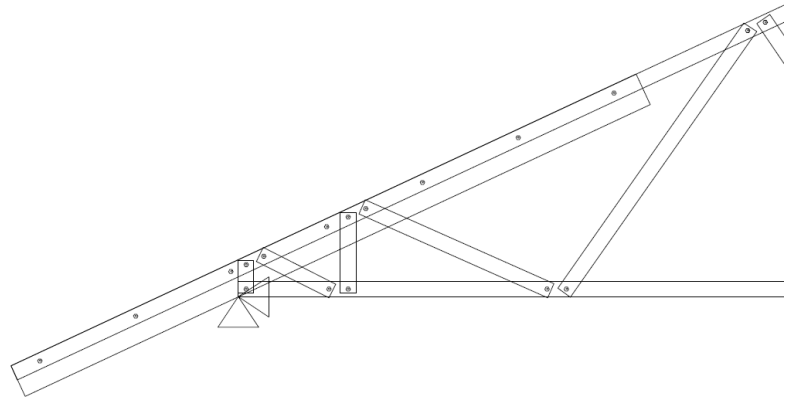

Dropped Eave – Additional members are added to the top chord overhang to create a flat soffit.

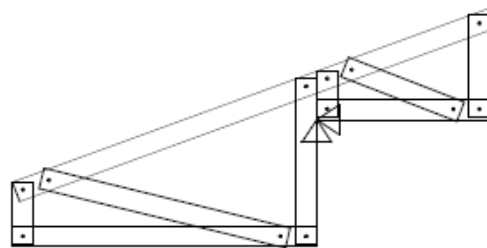

When Dropped Eave is selected, an Eave Option Tab will appear where you can define the dropped eave dimensions. Click on the button to the right of the 'Values Not Set' field.

Layouts * Options Claddings

Property	Value
Layouts Options	
System*	FRAMECAD_FT_m
Model Name	89mm LE System
Roof Load*	SHEET
Roof Pitch	25.000
Sub Pitch	25.000
Wind Speed (AS 4055)	N2
Ground Snow Load (kPa)	0.00
Reduced Level	2440
Hip Method	Half Truss
O/H Method	Overhang Frames
Eave Options	Dropped Eave
Layout Colour	256
Heel Height	0
Bracing Type*	FRAMECAD 32x115 Strap
Eave Options	
Eave Settings	Values Not Set
Truss Spacings	
Truss Spacing	900
First Truncated Truss	1200
Truncated Truss Spacing	900
First Jack Rafter	450
Next Jack Rafter	1200
Jack Rafter Spacing	900
Eave Search Distance	1200
Minimum Eave Length	100
Truss Offset	0

Eave Settings

Save Cancel

Property	Value
Trussed Eave Options	
'A' Drop Off Height	0
'B' Chord Setback	0
'C' Web Setback	0
Include Support	No
Minimum Eave	300

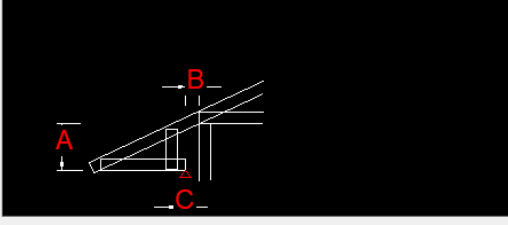

Save Cancel

The Minimum Eave distance is the minimum overhang that the dropped eave option will be applied to.

No Eave

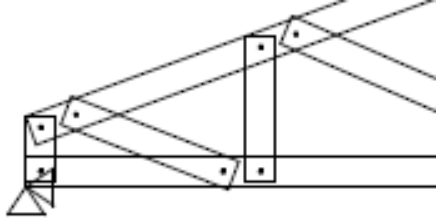
	
▪ Layout colour	Colour of the roof block.
▪ Heel Height	This is the truss heel height. To use a default calculated height, set this value to 0. The default height is based on the member depth in the LC orientation divided by cosine of the pitch.
▪ Bracing Type	Type of roof bracing material

2.4.1.2 Truss Spacings

▪ Truss Spacing	This sets the maximum spacing of the standard type trusses. It is defined as the distance from the centre of one truss to the next.
▪ First Truncated Truss	Location of the first truncated truss. It is defined as the distance from the end wall to the centre of the truncated truss.
▪ Truncated Truss Spacing	This sets the maximum spacing of the truncated trusses. It is defined as the distance from the centre of one truss to the next.
▪ First Jack Rafter	Location of the first jack rafter/half truss on a hip end roof. It is defined as the distance from the hip end corner to the centre of the first jack rafter/half truss.
▪ Next Jack Rafter	Location of the second jack rafter/half truss on a hip end roof. It is defined as the distance from the hip end corner to the centre of the next jack rafter/half truss.
▪ Jack Rafter Spacing	Maximum spacing of the jack rafters/half trusses on a hip end roof. It is defined as the distance from the centre of one jack rafter/half truss to the next.
▪ Eave Search Distance	The software will only search for a roof line within this distance. If a roof line is found within this distance, then no roof eave will be added.
▪ Minimum Eave Length	Any eave under this length will not be generated.
▪ Truss Offset	All trusses and jacks will automatically be cantilevered by this distance from the support lines selected.

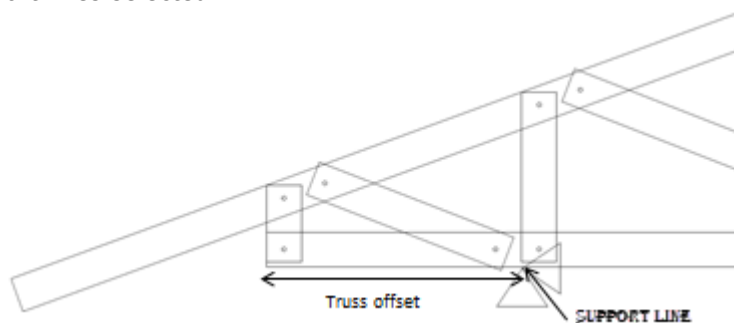

<ul style="list-style-type: none"> ▪ Ceiling Ties 	<p>This is the spacing of the ceiling ties along the truss bottom chord. Ceiling ties are only used if the ceiling batten spacing (see 'Batten Spacings') is set to zero or a figure greater than the value shown here, i.e. the item with the lowest value (but greater than zero) will take precedence.</p> <p>Ceiling ties are also required when setting the 'Suspended Ceilings' to 'True'. If you do not wish to use bottom chord ties at all, set this value to zero.</p>
<ul style="list-style-type: none"> ▪ Outrigger Spacing 	<p>This is the spacing of the gable roof overhang outriggers which extend out over the gable end truss top chord. This only applies when the 'O/H Method' is set to 'Outriggers'. It does not apply to Gable Frame members.</p>

2.4.1.3 Truss Spacings Types

<ul style="list-style-type: none"> ▪ Standard Absolute Spacing 	<p>False: Trusses will be evenly spaced within the available area with a truss spacing not exceeding the maximum truss spacing defined in the 'Truss Spacing' tab.</p> <p>True: Truss spacing will be the maximum truss spacing defined in the 'Truss Spacing' tab.</p>
<ul style="list-style-type: none"> ▪ Trunc Absolute Spacing 	<p>False: Truncated Trusses will be evenly spaced within the available area with a truncated truss spacing not exceeding the maximum truncated truss spacing defined in the 'Truss Spacing' tab.</p> <p>True: Truncated Truss spacing will be the maximum truncated truss spacing defined in the 'Truss Spacing' tab.</p>
<ul style="list-style-type: none"> ▪ Jack Absolute Spacing 	<p>False: Truncated Trusses will be evenly spaced within the available area with a truncated truss spacing not exceeding the maximum truncated truss spacing defined in the 'Truss Spacing' tab.</p> <p>True: Truncated Truss spacing will be the maximum truncated truss spacing defined in the 'Truss Spacing' tab.</p>
<ul style="list-style-type: none"> ▪ First Truncated as Girder 	<p>When the 'First Truncated as Girder' is set to 'True', the first truncated truss generated for a hip end will be a girder truss instead of a standard truss. As a result, web members will be aligned with the oncoming hip end trusses and the loads will be calculated using the 'Additional Area' method.</p> <p>Use this option for roofs with heavy loads or roofs where supported jack trusses are cantilevered past the support line.</p>
<ul style="list-style-type: none"> ▪ Trusses Use Nominal Spacing 	<p>Enables the truss engineering to use the design centres, as specified in the Truss Spacings section.</p> <p>By default, these are set to 'False', which will use the actual spacing of the trusses when input using the TD truss input method.</p> <p>NOTE: Truss spacings do not automatically adjust if trusses are moved or added in layout. The user must list trusses to alter the spacings if required.</p>
<ul style="list-style-type: none"> ▪ Jacks Use Nominal Spacing 	<p>As above.</p>

2.4.1.4 Truss Directions

Allows the user to set the orientation of LC (Deep Axis/B2B) truss systems on a truss layout plan prior to input. The settings for this can be found in **TSET – Layouts – Truss Directions**. *Only available in v11.1 onwards.*

The '**Truss Face Inwards**' options will have the webs of the trusses facing towards the centre of the roof block.

The '**Truss Face Outwards**' options will have the webs of the trusses facing towards the ends/corners of the roof block.

The '**Normalised**' options will orientate the trusses the same as if they were LE (inline) trusses.

Note that these can be set as default settings if you have a custom data file. You will need to submit a support ticket through MyFramecad to request this.

2.4.1.5 Loads

▪ Roof Live Load	Live Load from the roof which will be applied to the top chord of the truss. The unit is kPa for metric, and psf for imperial.
▪ Ceiling Live Load	Live Load from the ceiling which will be applied to the bottom chord of the truss. The unit is kPa for metric, and psf for imperial.
▪ Roof Dead Load	Dead Load from the roof which will be applied to the top chord of the truss. The unit is kPa for metric, and psf for imperial.
▪ Ceiling Dead Load	Dead Load from the ceiling which will be applied to the bottom chord of the truss. The unit is kPa for metric, and psf for imperial.
▪ Ceiling Service Load	Service Load from the ceiling which will be applied to the bottom chord of the truss. The unit is kPa for metric, and psf for imperial.
▪ Design Point Load	Truss point load applied at mid span of each major segment of the truss. A minimum point load of 0.5kN (0.112 kip) is considered.
▪ Suspended Ceilings	True: When using a suspended ceiling, the deflection criteria for the bottom chord is less restrictive. The Bottom chord restraints are still defined by the ceiling tie spacing defined in 'Truss Spacings' tab. False: Not using suspended ceiling.
▪ Shuttered Conditions	True: shuttered conditions (use of shutter in front of openings). With shuttered condition and cyclonic wind, the internal wind pressure coefficient will be taken as the non cyclonic internal wind pressure coefficient. False: non-shuttered conditions.
▪ Brick Clad Exterior	If selected, reduces the lateral wind applied to external wall frames.

2.4.1.6 Batten Spacings

▪ End Roof Batten Spacing	Maximum spacing from the first roof batten to the next roof batten. Usually the spacing here is less than that of the balance of the roof battens.
▪ Int Roof Batten Spacing	Maximum spacing of the roof batten excluding the first roof batten spacing. This value is used for engineering calculations and batten quantities.
▪ Ceiling Batten Spacing	Maximum spacing of the ceiling battens. This value is used for engineering calculations and batten quantities.

2.4.1.7 Roof Batten Settings

▪ First Batten Type	Type of roof batten used for the first row of battens around the building.
▪ First Batten Length	Finished cut length of the first roof batten that will be supplied. This value is used for bill of material calculations.

▪ First Batten Lap	The overlapping length that is allowed to join 2 first roof batten together. This value is used for first batten quantity calculation, using the batten full length minus the batten lap. This field can also be used to increase or decrease wastage.
▪ First Fixing Type	Screw type used to fix the first roof batten
▪ First Fixing Qty	Screw quantity per connection used to fix the first roof batten
▪ Next Batten Type	Type of internal roof batten used next to the first roof batten.
▪ Next Batten Length	Finished cut length of the internal roof batten that will be supplied. This value is used for bill of material calculations.
▪ Next Batten Lap	The overlapping length that is allowed to join 2 internal roof batten together. This value is used for internal batten quantity calculation, using the batten full length minus the batten lap. This field can also be used to increase or decrease wastage.
▪ Next Fixing Type	Screw type used to fix the internal roof batten
▪ Next Fixing Qty	Screw quantity per connection used to fix the internal roof batten

2.4.1.8 Ceiling Batten Settings

▪ End Ceiling Batten	Type of ceiling batten used for the first row of ceiling battens along the walls.
▪ Material Length	Finished cut length of the end ceiling batten that will be supplied. This value is used for bill of material calculations.
▪ Lap Allowance	The overlapping length that is allowed to join 2 end ceiling batten together. This value is used for end ceiling batten quantity calculation, using the batten full length minus the batten lap. This field can also be used to increase or decrease wastage.
▪ Int Ceiling Batten	Type of internal ceiling batten used next to the first row of ceiling battens along the walls.
▪ Material Length	Finished cut length of the internal ceiling batten that will be supplied. This value is used for bill of material calculations.
▪ Lap Allowance	The overlapping length that is allowed to join 2 internal ceiling batten together. This value is used for internal ceiling batten quantity calculation, using the batten full length minus the batten lap. This field can also be used to increase or decrease wastage.
▪ First Fixing Type	Screw type used to fix the end ceiling batten
▪ First Fixing Qty	Screw quantity per connection used to fix the end ceiling batten
▪ Next Fixing Type	Screw type used to fix the internal ceiling batten
▪ Next Fixing Qty	Screw quantity per connection used to fix the internal ceiling batten

2.4.1.9 Valley Supports

▪ First Valley Support	Type of batten that will be used to support the sides of the valley gutter.
▪ Material Length	Finished cut length of the member that will be supplied. This value is used for bill of material calculations.

▪ Lap Allowance	The overlapping length that is allowed to join 2 valley support batten together. This value is used for quantity calculation, using the batten full length minus the batten lap. This field can also be used to increase or decrease wastage.
▪ Next Valley Support	Type of batten that will be used to support the sides of the valley gutter.
▪ Material Length	Finished cut length of the member that will be supplied. This value is used for bill of material calculations.
▪ Lap Allowance	The overlapping length that is allowed to join 2 valley support batten together. This value is used for quantity calculation, using the batten full length minus the batten lap. This field can also be used to increase or decrease wastage.

2.4.1.10 Solar Panels

2.4.1.11 Roof Panel Options

Allows you to set the roof panel parameters when using the 'Panel Jack' hip end type. Refer to Smart Panel Commands for settings.

2.4.2 Options Tab

2.4.2.1 Height Split Options

▪ Max Height	This is the maximum height required when splitting trusses horizontally.
▪ Required Gap	This is the gap requirement between the top and bottom halves of a split truss. This distance would generally be set to the depth of roof battens which are required to restrain the main truss, then the top hat truss section is attached on top of these battens.

2.4.2.2 Labels Options

▪ Truss Type	Prefix that will be given to each type of truss listed. It is recommended to keep the prefix to less than 3 characters. Spaces or punctuation are not allowed.
▪ Continuous Numbering	If set to TRUE, then the truss labelling will start at 1 and continue for all the trusses regardless of the truss type. If set to FALSE, then the numbering will restart from 1 for each truss type.
▪ Auto Label Layout	If set to TRUE, trusses will automatically be labelled on input.

2.4.2.3 Report Options

▪ General Notes	Select true for all information needed in the report.
▪ Minimum Uplift Value	Any values less than the value indicated will not display on the Truss Uplift Plan. Generally, this would be used for plan clarity.

2.4.2.4 Detail Sheet Options

Options to be included or excluded on the truss elevations in Detailing Space	
▪ Include Materials	Turns the material list on or off

▪ Collect Common Length	Combines common lengths in the cutting list.
▪ Include Parts	
▪ Include Design Summary	
▪ Show Major Dimensions	
▪ Show Minor Dimensions	
▪ Show Engineering Percentage	
▪ Show Uplifts	
▪ Border Sized to Fit	If set to FALSE, the largest border size required will be used for all trusses.
▪ Auto Update Supports	
▪ Engineering Detail Report	

2.4.2.5 Dimension Options

▪ General Notes	Choose Location of Dimensions appearing on the layout drawings
-----------------	--

3 General Commands

3.1 ADD – Border

Commands:

Global name: `_LAYOUT_MANAGER`

Local name: `LAYOUT_MANAGER`

Alias: **ADD or A**

Space: `Layout Space`

Purpose:

Launches the Border Setup only if no borders exist.

Process:

Type ADD or A then right click or press Enter.

Additional Information:

3.2 ADD – Wall

Commands:

Global name: `_LAYOUT_MANAGER`

Local name: `LAYOUT_MANAGER`

Alias: **ADD or A**

Space: `Layout Space`

Purpose:

Inputs a single wall frame by points or lines and multiple wall frames by lines.

Process:

- Type ADD then press Enter.
- Select the Wall tab.
- All the options in the 'General Values' will be populated according to the Wall settings (PSET).
- Changing any of the 'General Values' will precede what is in the Wall settings.
- Settings in the 'Other Values' section will be applied if the walls do not find any referenced truss or joist loadings on the plan.

Tip: Double clicking on a Property will automatically change to the next option in the 'Value' column.

General Values	
<ul style="list-style-type: none"> ▪ System Name 	<p>The system to be used for the wall panels. You may mix systems within a single job.</p> <p>Note: To save system settings as default, hold down the 'ALT' key and click on 'System Name*'. See Additional Information below.</p>

<ul style="list-style-type: none"> ▪ Current Model 	<p>This is the sub system or member profile requirements for the job. If a user has a list of commonly used profile sizes, this list can be modified to suit by requesting a custom data file through the FRAMECAD Care section under 'My Support' in https://my.framecad.com</p> <p>Note: To save current model settings as default, hold down the 'ALT' key and click on 'Current Model*'. See Additional Information below.</p>
<ul style="list-style-type: none"> ▪ Panel Usage 	<p>Load Bearing: The wall will be designed for vertical and horizontal loads. Non-Load Bearing: The wall will not be designed for vertical load. Structural: The wall will be designed for vertical and horizontal loads but presumes that the wall is not point loaded in any way, i.e. studs will not be placed under trusses or joists even if required.</p>
<ul style="list-style-type: none"> ▪ Roof Load 	<p>Linked to the truss settings from the 'TSET' command. Changing this value will open the Truss Settings where you can make the change and Save. Changing the roof load will not change the settings of any trusses which have already been built.</p>
<ul style="list-style-type: none"> ▪ Floor Type 	<p>Set what type of floor the wall is fixed to. There are currently 3 choices, 'Concrete', 'Steel' and 'Timber'. This is used to calculate the bill of material and/or the strength of hold down fasteners.</p>
<ul style="list-style-type: none"> ▪ Wind Speed 	<p>Linked to the truss settings from the 'TSET' command. Changing this value will open the Truss Settings where you can make the change and Save. Changing the roof load will not change the settings of any trusses which have already been built.</p>
<ul style="list-style-type: none"> ▪ Wall Height 	<p>This is the height from the base to the top of the wall frame top plate, assuming the wall is not raked.</p>
<ul style="list-style-type: none"> ▪ Base Level 	<p>This is the base level of the wall frame bottom plate. This value is critical as the software uses it to create 3D models and for the purpose of load transfers. The 'S3D' command will allow the user to detect any base level mistakes.</p>
<ul style="list-style-type: none"> ▪ Opening Options 	<p>Settings coming from the 'PSET' command. They can be changed here without modifying the 'PSET' settings.</p>
<ul style="list-style-type: none"> ▪ Opening Head Style 	<p>Lintel Head: Header which only uses vertical webs as long as the Lintel Head passes the engineering analysis. It can be reinforced with 1 L plate or 2 L plates fixed on each side of the opening at the top of the frame. In case the engineering status of the Lintel Head has failed with the reinforced L plates, the software will automatically add diagonal webs to reinforce the Header.</p> <p>Webbed Head: Webbed Header using diagonal webs. The webbed Head can be reinforced with 1 L plate or 2 L plate fixed above the opening. The web pattern can be changed by listing the opening.</p> <p>Beam Head: Header composed of a Deep Cee Joist. The Deep Cee profile can be changed by listing the opening.</p>
<ul style="list-style-type: none"> ▪ LB Web to Openings 	<p>Maximum width for openings without diagonal webs in Load Bearing walls. Opening above this width will have web added even if the software engineering analysis says they are not required. When set to zero, no maximum width will be considered.</p>
Other Values	
<ul style="list-style-type: none"> ▪ Drafting colour 	<p>Set colour of the wall.</p>
<ul style="list-style-type: none"> ▪ Extra Truss Span 	<p>Allows to enter an extra truss span in order to add extra roof load to the wall in addition with any other load already applied to the wall through truss and or floor layouts. Note that the roof load taken in account for this extra truss span will be the one defined in the 'TSET' command.</p>

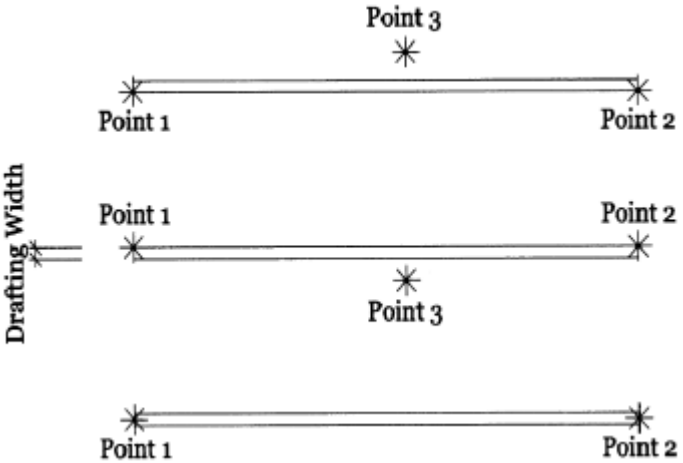
<ul style="list-style-type: none"> ▪ Truss Pitch 	<p>This is the pitch of the extra truss span. It is the angle of the extra truss slope defined in decimal degrees. If you wish to define the truss pitch by rise over run, then click on the ellipsis button to the right of this field. Enter in the run and rise values (the pitch field will automatically update) then click on 'Transfer' to place this value into the main dialogues pitch field.</p>
<ul style="list-style-type: none"> ▪ Extra Floor Span 	<p>Allows to enter an extra floor span in order to add extra floor load to the wall in addition with any other load already applied to the wall through truss and or floor layouts. Note that the Floor load taken in account for this extra floor span will be the one defined in the 'JSET' command.</p>
<ul style="list-style-type: none"> ▪ Extra Snow Load 	<p>Allows to set a specific snow load to the extra truss span</p>
<ul style="list-style-type: none"> ▪ Stud Spacing 	<p>Stud spacing measured from face to face of the stud. This value may be updated in accordance with the engineering analysis results of the wall panel.</p>
<ul style="list-style-type: none"> ▪ Ext Wall Mass 	<p>Weight of the wall panel cladding when it is used as an external wall panel. The unit is KPa for metric, and psf for imperial.</p>
<ul style="list-style-type: none"> ▪ Int Wall Mass 	<p>Weight of the wall panel cladding when it is used as an internal wall panel. The unit is KPa for metric, and psf for imperial.</p>
<p>Creation Options</p>	
<ul style="list-style-type: none"> ▪ Code as you go 	<p>True : Will code the frames as they are input. False : Will allow for un-coded frames. Frames will then need to be coded using the List (LI) command.</p>
<ul style="list-style-type: none"> ▪ Creation Method 	<p>By Points :</p> <ul style="list-style-type: none"> ▪ Click on 'Create'. ▪ Select the start point and end point of the wall, then the direction (or side of line) to offset the frame. ▪ This option can be set to code the walls on input. ▪ The Panel Draw (PD) command also achieves the same result.  <p>By Lines :</p> <ul style="list-style-type: none"> ▪ Create a line or polyline. ▪ Click on 'Create'. ▪ Select the line or polyline then click on the side of the line/polyline for the wall placement. ▪ Walls input using this method can be coded on input if 'Code as you go' is set to 'True'. ▪ Use the Member Fillet (MF) command to tidy up any wall intersections.

<ul style="list-style-type: none"> Erase original entity 	<p>True : Will erase the line entities when walls are created using the 'By Lines' input method.</p> <p>False : Will leave the line entities in place when walls are created using the 'By Lines' input method.</p>
---	---

Additional Information:

The ADD command activates BSET on a new drawing if no borders are present.

3.3 ADD – Beam

Commands:

Global name: `_LAYOUT_MANAGER`

Local name: `LAYOUT_MANAGER`

Alias: **ADD or A**

Space: `Layout Space`

Purpose:

Inputs a single beam by points or lines.

Note: Beams are detailed only. The loads carried and incurred by these are not transferred to structural elements. Beams are not considered nor calculated by the software and should be engineered by others.

Process:

- Type ADD then press Enter.
- Select the Beam tab.
- Check and change the parameters as required.

General Values	
<ul style="list-style-type: none"> System Name 	<p>This should be set to the same system name as that used for the wall panels in PSET, however you may mix systems within a single job.</p> <p>Please also ensure you have set the required default BeamsPosts data file in the BSET – Options – Drawing Options dialogue.</p> <p>Beams will then first be selected from the data file as set in the ADD dialogue (if any exist there), then further selections will be made from the BeamsPosts data file that is set in BSET – Drawing Options.</p>
<ul style="list-style-type: none"> Beam Category 	<p>List of pre-defined beam types to select from, i.e. Webbed, Lipped Cee, PFC, RHS, UB, etc.</p>
<ul style="list-style-type: none"> Beam Name 	<p>Select the name of the type of beam to be used.</p>
<ul style="list-style-type: none"> Model Type 	<p>This option is only available for Webbed Beams. Select the profile type to be used.</p>
<ul style="list-style-type: none"> Beam Top RL 	<p>This is the relative level of the top of the beam.</p> <p>Changing this value will alter the Base RL relative to the beam height.</p>
<ul style="list-style-type: none"> Beam Base RL 	<p>This is the relative level of the underside of the beam.</p> <p>Changing this value will alter the Top RL relative to the beam height.</p>

▪ Beam Height	This is the Height of the beam. This value will be automatically generated after the selection of the 'Beam name' and can also be manually changed. Changing this value will alter the Base RL while maintaining the Top RL.
▪ Beam Width	This is the width of the beam. This value will be automatically generated after the selection of the 'Beam name' and can also be manually changed.
▪ Drafting Colour	Sets colour of the beam.
▪ Wind Beam Option	Allows the user to add a Wind Beam (boxed stiffener plate) to the top or bottom or both top and bottom of the beam.
▪ Treat as Non-Structural	As beams are not engineered, this option does not affect anything.
▪ Detail This Item	If set to 'No', beam will not be sent to the Wall Builder (PPD)
Creation Options	
▪ Creation Method	<p style="text-align: center;">By Points:</p> <ul style="list-style-type: none"> ▪ Click on 'Create'. ▪ Select the start point and end point of the beam, then the direction (or side of line) to offset the beam. <p style="text-align: center;">By Entity:</p> <ul style="list-style-type: none"> ▪ Click on 'Create'. ▪ Select a line entity then click on the side of the line for the beam placement.

Additional Information:

More options are available when listing (LI) the beam. See LI – List Item – Beam Editor.

Beams running over the top of walls places a single stud in the wall below the beam.

The ADD command activates BSET on a new drawing if no borders are present.

3.4 ADD – Post

Commands:

Global name: `_LAYOUT_MANAGER`

Local name: `LAYOUT_MANAGER`

Alias: **ADD or A**

Space: `Layout Space`

Purpose:

Inputs a series of posts by points or lines.

Process:

- Type ADD then press Enter.
- Select the Post tab.
- Check and change the parameters as required.

General Values

<ul style="list-style-type: none"> System Name 	<p>This should be set to the same system name as that used for the wall panels in PSET, however you may mix systems within a single job.</p> <p>Please also ensure you have set the required default BeamsPosts data file in the BSET – Options – Drawing Options dialogue.</p> <p>Posts will then first be selected from the data file as set in the ADD dialogue (if any exist there), then further selections will be made from the BeamsPosts data file that is set in BSET – Drawing Options.</p>
<ul style="list-style-type: none"> Post Type 	Select the post type to be used. If you wish to add more posts to your data file refer to the instructions at the end of this section.
<ul style="list-style-type: none"> Post Size (W x D) 	Post dimensions are automatically generated after selecting the Post Type and cannot be changed manually.
<ul style="list-style-type: none"> Post Profile 	Post profile shape (ie Round, Square...) is automatically generated after selecting the Post Type and cannot be changed manually.
<ul style="list-style-type: none"> Maximum Post Spacing 	Maximum spacing between the post when a run of posts is inserted. If required post may be moved after they have been inserted.
<ul style="list-style-type: none"> Post Overall Height 	This is the overall height of the post. It will appear on the cutting lists.
<ul style="list-style-type: none"> Post Base RL 	Relative level of the base of the post.
Creation Options	
<ul style="list-style-type: none"> Creation Method 	<p>By Points :</p> <ul style="list-style-type: none"> Click on 'Create'. Select the start point for the first post, then the end point of the last post, then the direction (or side of line) to place the posts. Posts will be placed at spacings equal to or less than the 'Maximum Post Spacing' specified in the General Values. <p>By Entity :</p> <ul style="list-style-type: none"> Click on 'Create'. Select a line entity then click on the side of the line for the post placement. Posts will be placed at spacings equal to or less than the 'Maximum Post Spacing' specified in the General Values.

Additional Information:

The ADD command activates BSET on a new drawing if no borders are present.

3.5 ADD – Opening

Commands:

Global name: `_LAYOUT_MANAGER`

Local name: `LAYOUT_MANAGER`

Alias: **ADD or A**

Space: `Layout Space`

Purpose:

Inputs openings into wall frames.

Process:

- Click on the 'Settings' button at the bottom of the dialogue box to go to the Opening Settings (PSET) if required. 'Save' or 'Cancel' will return the user to the ADD dialogue.
- Double click on the door or window type to start the input.
- Follow the prompts in the command bar.

Tip: user defined doors and windows can be input directly by using the UD and UW commands respectively.

Additional Information:

The ADD command activates BSET on a new drawing if no borders are present.

3.6 ADD – Joist

Commands:

Global name: `_LAYOUT_MANAGER`

Local name: `LAYOUT_MANAGER`

Alias: **ADD or A**

Space: `Layout Space`

Purpose:

Inputs a single joist by points or lines.

Process:

- Type ADD then press Enter.
- Select the Joist tab.
- Click on the 'Settings' button at the bottom of the dialogue box to go to the Floor Settings (JSET) if required. 'Save' or 'Cancel' will return the user to the ADD dialogue.
- Check and change the parameters as required.
- Changing any of the 'General Values' will precede what is in the Joist settings.

Creation Options	
▪ Auto Label Member	True : Activates auto label and automatically relabels the floor joist layout. False : Deactivates auto label.
▪ Auto Cutting List	True : Automatically recreate the on page floor member summary report False : Does not recreate the on page floor member summary report
▪ Creation Method	<p style="text-align: center;">By Points :</p> <ul style="list-style-type: none"> ▪ Click on 'Create'. ▪ Select the start point and end point of the joist, then the direction (or side of line) to offset the joist. <p style="text-align: center;">By Entity :</p> <ul style="list-style-type: none"> ▪ Click on 'Create'. ▪ Select a line entity then click on the side of the line for the joist placement.

Additional Information:

The ADD command activates BSET on a new drawing if no borders are present.

3.7 ADD – Truss

Commands:

Global name: `_LAYOUT_MANAGER`

Local name: `LAYOUT_MANAGER`

Alias: **ADD or A**

Space: `Layout Space`

Purpose:

Inputs a single truss by points or lines.

Process:

- Type ADD then press Enter.
- Select the Truss tab.
- Check and change the parameters as required.
- Changing any of the 'General Values' will precede what is in the Truss settings.

Creation Options	
<ul style="list-style-type: none"> ▪ Creation Method 	<p style="text-align: center;">By Points :</p> <ul style="list-style-type: none"> ▪ Click on 'Create'. ▪ Select the start point and end point of the truss, then the direction (or side of line) to offset the truss. <p style="text-align: center;">By Entity :</p> <ul style="list-style-type: none"> ▪ Click on 'Create'. ▪ Select a line entity then click on the side of the line for the truss placement.
<ul style="list-style-type: none"> ▪ Add Eaves 	<p>True : Will add truss eaves if Roof Lines are present and are within the eave search distance as set in the TSET settings.</p>
<ul style="list-style-type: none"> ▪ Auto Label Truss 	<p>True : Will automatically label the truss on input. This option will also automatically update the truss labels on other trusses present in the job. Labels will automatically be changed to suit the truss locations.</p> <p>False : Will not label the truss. Use this option if you have other trusses present that you do not wish to have labels inadvertently updated.</p>

Additional Information:

The ADD command will activate BSET on a new drawing if no borders are present.

3.8 ADD – Truss/Joist/Wall Members

Commands:

Global name: `_LAYOUT_MANAGER`

Local name: `LAYOUT_MANAGER`

Alias: **ADD or A (or CM for Code Member)**

Space: `Detailing Space`

Purpose:

To add an individual member to a truss, joist or wall in detailing space.

Process:

- Ensure Ortho mode is either ON or OFF depending on the input requirements.
- Type A then right click or press Enter to open the:
 - 'Code as Truss Member' dialogue box for trusses,
 - 'Code as Floor Member' dialogue box for joists,

- 'Code as Wall Member' dialogue box for walls.
- Change parameters as described in the following table.

General Values:	
▪ Material Usage	Trusses - Top Chord / Horizontal Top Chord / Bottom Chord / Web / Rail Joists - Bottom Chord / Top Chord / Rail / Vertical Web / Angular Web Walls - Members as listed in dialogue drop down
▪ Material Name	Set to 'Auto' unless a different material type is required.
▪ Auto Complete	True - This will label the member and re-engineer the truss on completion of input. False - Member will be input without label or re-engineering.
▪ Method	By Points - Allows for a start and finish point to be selected. By Entity - Select a line entity to convert to a member.

Additional Information:

- When inputting a vertical web into a truss, ensure ortho mode is ON and input method is set to 'By Points', select the first point along a chord member, then select the second point between the two edges of the opposite chord member (i.e. do not select on the chord edge line). The web member will automatically be adjusted to fit between the 2 chord members.

Also see: IW - Insert Web for alternative truss member input method.

The ADD command activates BSET on a new drawing if no borders are present.

3.9 C3D – Copy to Model

Commands:

Global name:	COPYMODEL
Local name:	_COPYMODEL
Alias:	C3D
Space:	Layout Space

Purpose:

Allows the user to easily copy selected entities/items from the Layout space into the exact same co-ordinate location in the Model space. The co-ordinate location in Model space will be determined by the presence of REF markers in the layouts.

Process:

- In Layout Space, type C3D then right click or press Enter.
- Select the entities/items to be copied.
- Right click – selected items will appear in Model Space

Additional Information:

3.10 CB – Clear Border

Commands:

Global name:	ClearBorder
Local name:	_ClearBorder
Alias:	CB
Space:	Layout and Detail Space

Purpose:

Clears the entire contents of a border.

Process:

- Ensure that the border to clear is centralised on the screen.
- Type CB then right click or press Enter.

Additional Information:

3.11 CC – Copy Posts

Commands:

Global name:	COPYPOST
Local name:	_COPYPOST
Alias:	CC
Space:	Layout Space

Purpose:

Copies posts from one view (layout) to another and removes all entity system information from the copied posts.

Process:

- Ensure that the plan to copy from is centralised on the screen.
- Type CC then right click or press Enter.
- Press Enter for entire view selection.

OR

- Select the posts to be copied.
- Press Enter to accept. The drawing will zoom out to include all border views.
- Select anywhere within the border to copy to.

Additional Information:

3.12 CSL - Create Support Line

Commands:

Global name:	CREATE_SUPPORT
--------------	----------------

Local name: _CREATE_SUPPORT
Alias: CSL
Space: Layout Space

Purpose:

Creates support lines on a plan based on the centreline of selected walls or beams from another plan.

Process:

- Ensure that the plan to copy from is centralised on the screen.
- Type CSL then right click or press Enter.
- Select the walls and/or beams.
- Press Enter to accept. The drawing will zoom out to include all border views.
- Select anywhere within the border to copy to.

Additional Information:

3.13 CTH - Convert to Hexagonal End

Commands:

Global name: _TO_HEX
Local name: TO_HEX
Alias: CTH
Space: Layout Space

Purpose:

Converts the square end of a building to a hexagonal end. The resulting lines will all be of equal length.

Process:

- Type CTH then press Enter.
- Select the end line and then

3.14 CTR – Centered

Commands:

Global name: _CENTERED
Local name: CENTERED
Alias: CTR
Space: Layout and Detailing Space

Purpose:

Allows the user to select an entity or number of entities and move them to the centre of a border.

Process:

- Type CTR then right click or press Enter.
- Select the items you wish to move.
- Right click or Enter to finish.

Additional Information:

Centering ignores the size and location of the title block within a border.

3.15 CV - Copy View

Commands:

Global name:	COPYVIEW
Local name:	_COPYVIEW
Alias:	CV
Space:	Layout Space

Purpose:

Copies selected entities from one view (border) to another. The border to copy entities from must be centralised on the screen for this command to work.

Process:

- Ensure that the view you are copying from is centralised on your screen.
- Type CV then right click or press Enter.

Additional Information:

3.16 DET - Detail/Frame Builder

Commands:

Global name:	_DETAIL
Local name:	DETAIL
Alias:	DET
Space:	Layout and Detailing Space

Purpose:

This is a universal command that performs the same function as the TTD, PPD and JJD commands, with the exception that the frames to be built must be in focus on the screen.

Process:

- Ensure that the frame type to be built is in focus on the screen.
- Type DET then right click or press Enter.

Additional Information:

When a layout is in focus and if frames of the same type, e.g. wall frames, also occur on another layout, all frames of that type in the job will be built, i.e. will include the frames on other layouts.

3.17 DO_ONCE - Reset CAD Environment

Commands:

Global name:	_DO_ONCE
Local name:	DO_ONCE
Alias:	do_once
Space:	Layout and Detailing Space

Purpose:

Resets the CAD environment to the default values required by the Operating System.
To be used if the 'Design' menu is missing from the menu bar or aliases are not working.

Process:

- Type 'do_once' then press Enter.

Additional Information:

This command generally only needs to be used after the initial installation of the software.
Also, to be used to fix menu and alias issues.

3.18 ET - Explicit Tool Input

Commands:

Global name:	_ TOOL_ACTION
Local name:	TOOL_ACTION
Alias:	ET
Space:	Detailing Space

Purpose:

Allows the user to manually add extra tooling to framing members in elevation view.
Allows the user to increase the length of a member while also adding any selected tooling to framing members in elevation view, but will not show the increase in the layout or 3D views – Composite Options.

Process:

- Type ET then press Enter.
- The following dialogue will open.

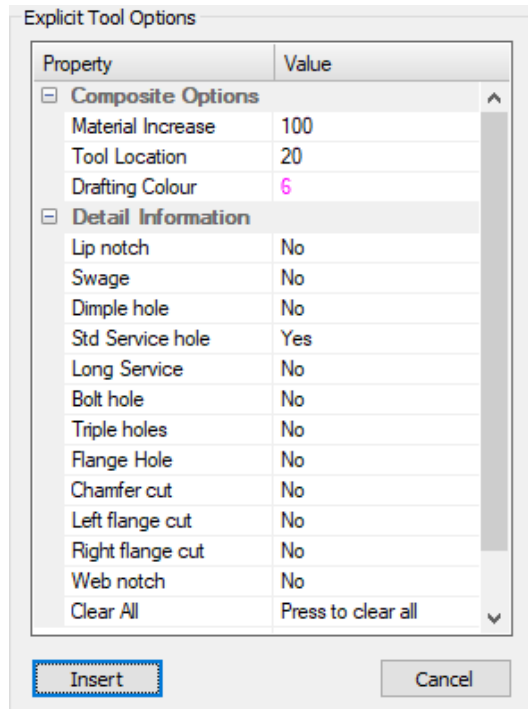

- Select the required tool (or combination of tools) from the Detail Information by changing the option to 'Yes'.
 - Select 'Insert'
 - Select a point along a member and right click to insert the tooling indicator line.
 - OR
 - Select a first and second point across the member at the location where you wish to place the selected tool actions. The line must cross the centre of a member for it to take effect.
 - Please note that where the line intersects the centre of a member, this indicates the centreline of the tool action selected.
-
- Composite Tool Input:
 - Set the material length as required
 - Set the tool action location as required. This is the distance from the end of the member to the centre of the tool action.
 - Select the drafting colour for the tooling indicator line.
 - Select 'Insert'
 - While holding the Alt key down, click on (or close to) the end of the member in the frame elevation that you wish to place the Composite Tool Action. An indication marker line will be placed at the centre of the end of the member.

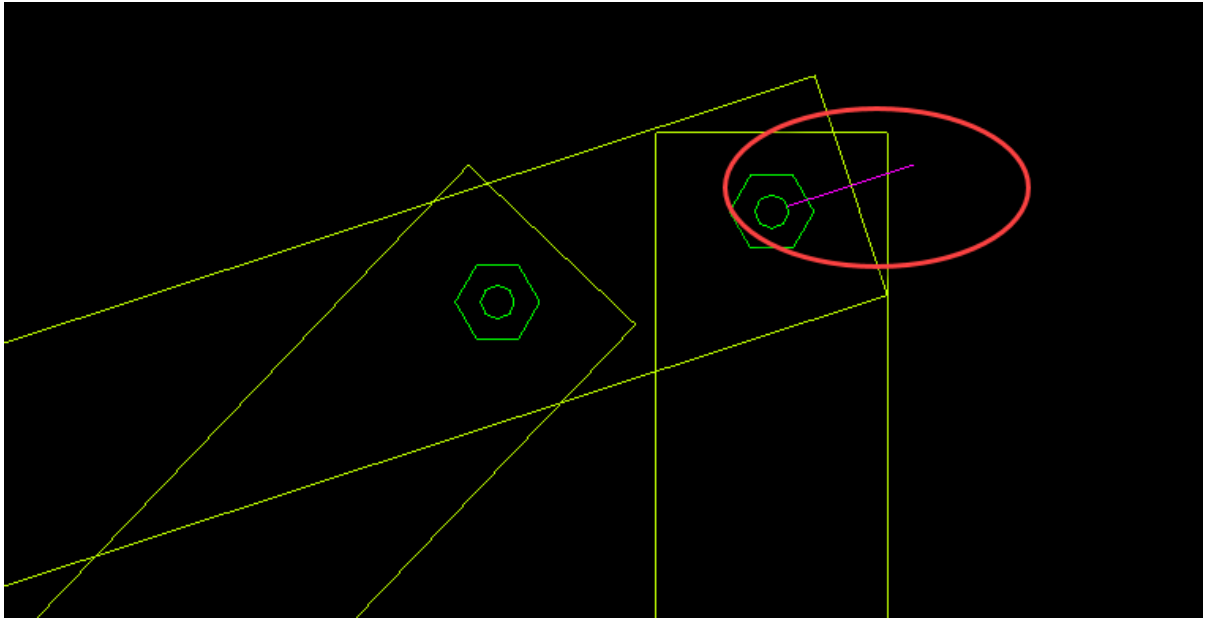

Additional Information:

Tool Action List	
Composite Options	
Material Increase	Length to increase a member by
Tool Location	Distance in from the end of a member to apply any selected tool actions
Drafting Colour	Colour applied to the tooling indicator line
Detail Information	
▪ Lip notch	To add a lip cut
▪ Web Notch	To add a web notch
▪ Left Flange Notch	To cut the left flange
▪ Right Flange Notch	To cut the right flange
▪ Mitre Notch	To add a flange chamfer
▪ Std Service Hole	To add a standard web service hole
▪ Long Service	To add a long web service hole
▪ Hold Down Hole	To add a web hold down hole
▪ Bolt Hole	To add a web bolt hole
▪ Truss Hole	To add triple web hole
▪ Flange Hole	To add a flange hole
▪ Swage	To add a swage
▪ Dimple	To add a dimple

▪ Clear All	Resets all selections back to 'False'
-------------	---------------------------------------

Composite Tool

Listing (LI) a Tool:

- Type LI and select the Explicit Tool line.
- Right click, press Enter or Spacebar to open the Tool Editor.

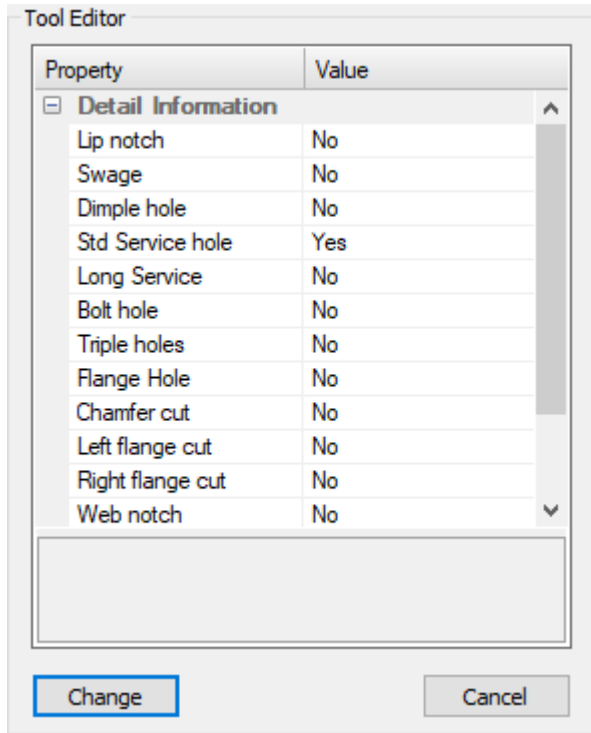

- Lists the tool type that was used on Explicit Tool input. This can then be changed in the editor if required.

3.19 FFIND - Find Item

Commands:

Global name:	_FIND_ITEM
Local name:	FIND_ITEM
Alias:	FFIND or FF
Space:	Layout and Detailing Space

Purpose:

To easily locate a member.

Process when in Layout Space:

- Type FFIND and press Enter.
- Type in the name of the member then right click or press Enter to finish.
- The item(s) is highlighted with an asterisk.

Process when in Detailing Space:

- Type FFIND and press Enter.
- Type in the name of the member then right click or press Enter to finish.
- The item is centred on the screen.

To find a member in the Layout Space when in Detailing Space:

- Ensure the required truss/panel/joist is centred on the screen.
- Type FFIND and press Enter twice.
- Program momentarily switches to the Layout Space and highlights the members with an asterisk.

Additional Information:

- FIND is a standard IntelliCAD command used to find and replace text.

3.20 GL – Gridline

Commands:

Global name:	_GRIDLINE
Local name:	GRIDLINE
Alias:	GL
Space:	Layout and Detailing Space

Purpose:

Allows the user to input a series of gridlines on the layout.

Process:

- Type GL then right click or press Enter.
- Select the start point for the first gridline.
- Select the end point for the gridline.
- Select the location for each subsequent gridline.
- Press Enter or right mouse click to finish.

Additional Information:

The Gridline settings can be found in BSET – Options – Gridline Options.

Listing a Gridline:

- Type LI and select the Gridline.
- Right click or press Enter or Spacebar to open the Gridline Editor.

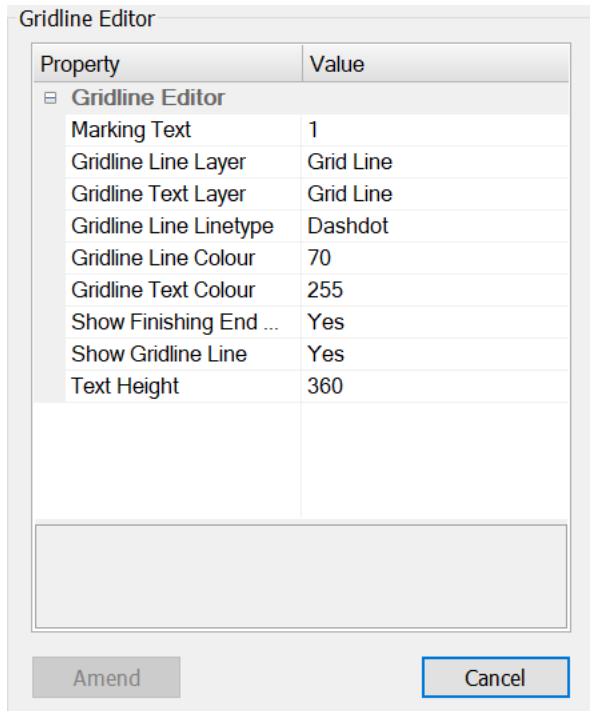

- Marking Text
- Gridline Line Layer
- Gridline Text Layer
- Gridline Line Linetype
- Gridline Line Colour
- Gridline Text Colour
- Show Finishing End Marker
- Show Gridline Line
- Text Height

3.21 IC – Integrity Check

Commands:

Global name:	<code>_MEMBER_CHECK</code>
Local name:	<code>MEMBER_CHECK</code>
Alias:	IC or CHECK
Space:	Layout and Detailing Space

Purpose:

This command is used to check for drafting errors and simple mistakes made by the detailer. It checks for eleven major errors and issues two types of warnings. It should be stressed that this command could not be used enough. It should be used several times on EVERY job. Whilst it should not be relied upon, this command could be your best friend, and save much

embarrassment by attempting to eliminate errors. The eleven major errors detected are listed below:

Integrity of reference points		(critical warning)
Wall panels that are not coded	(cyan)	(warning only)
Wall panels that are not labelled	(yellow)	(warning only)
Wall panels that are short	(blue)	(warning only)
Wall panels that are overlapping	(yellow)	(warning only)
Wall panels exceeding maximum length	(magenta)	(warning only)
Wall panels exceeding transport limitations	(magenta)	(warning only)
Openings spread over two wall panels	(brown)	(warning only)
Braces spread over two wall panels	(brown)	(warning only)
Imposed panel loads		(warning only)
Duplicate labels		(warning only)
Entities of very small lengths	(red)	(critical warning)
Entities with a 'Z' coordinate value	(red)	(critical warning)
Engineering failures	(red++)	(warning only)

The various CHECK options can be enabled or disabled in the Integrity Check Options within the PSET dialogue box.

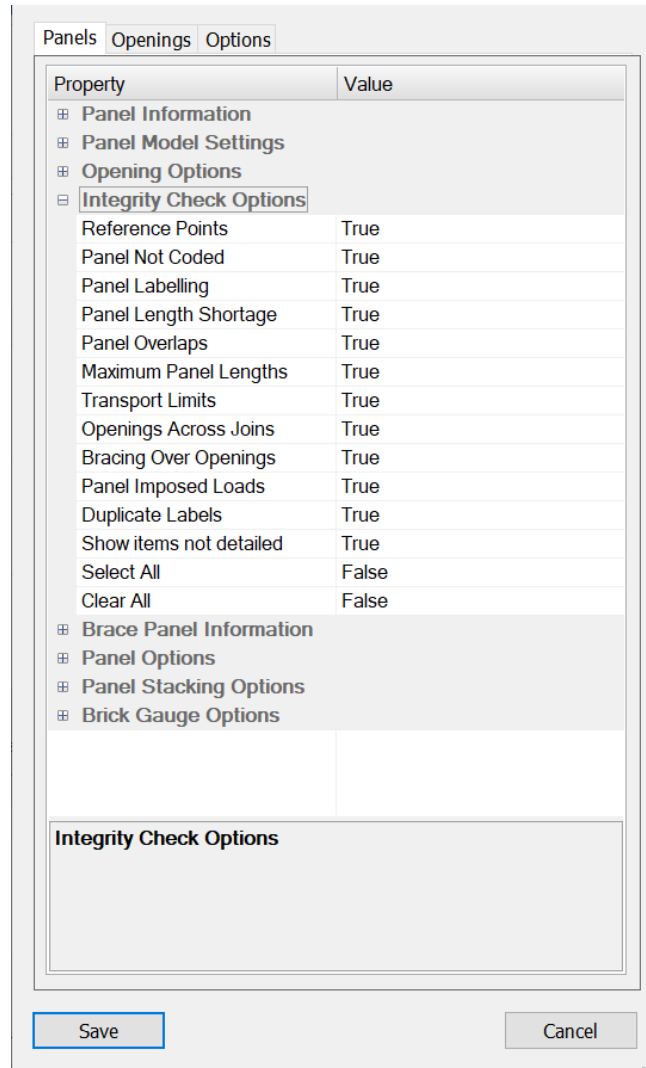

The two types of warnings issued are 'Critical Warnings' and 'Warning Only'. Should you receive a 'Critical Warning' then this MUST be fixed before proceeding any further, but a 'Warning Only' is purely up to your own discretion. Whenever a 'Critical Warning' is generated or present, the 'PPD - Panel Builder' command will not operate. Once a 'Critical Error' has been detected, the only way to clear the error is to fix the problem and run the 'CHECK' command until the 'Critical Error' warning does not appear.

Of the twelve warnings, only the first ten are optional and can be accessed via the settings option. We do recommend that 'Reference Points', 'Panel Length Shortage' and 'Panel Overlaps' remain on at all times as these are a major cause of drafting errors.

Process:

- Type IC then press Enter. It is important to remember that the 'CHECK' command will only check items found in the current view.
- Enter again to go to the setup. This allows the user to turn on or off items as required.
- Select Save or Cancel to go back to the layout.
- Select the items to be checked and Enter or right click.
- When an error is found, the location is marked with an asterisk and a warning box appears showing the errors found. The asterisk is colour coded making it easy to identify the error at that point. The colours used are listed above beside each error type.

- The warning box can be moved to one side to see the indicated errors on the plan.

3.22 ID – Insert Detail

Commands:

Global name:	_INSERT_DETAIL
Local name:	INSERT_DETAIL
Alias:	ID
Space:	Layout and Detailing Space

Purpose:

Inserts predefined details onto the drawing.

Process:

- Type ID then enter.
- The 'Detail Inserts' form opens.

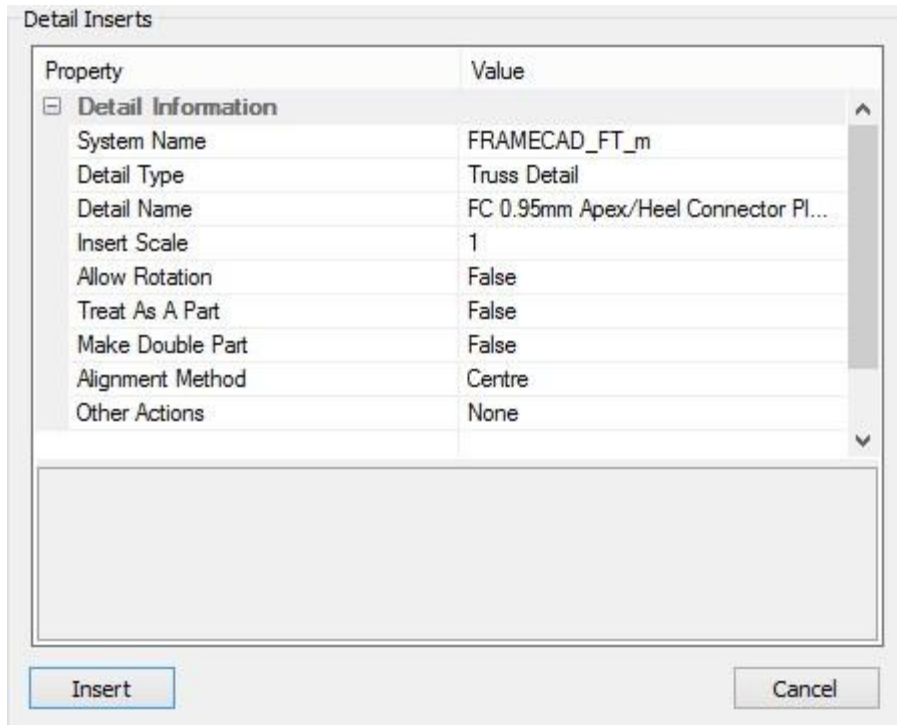

- Select the 'Detail Type' from the drop down menu.
- Select the 'Detail Name' from the drop down menu.
- Change any of the other parameters as required.
- Click the Insert button.
- Click on the required plan location.
- To add a detail:
- In the 'Other Actions' drop down, select Add Detail.
- Click on 'Add'.

- Select entities for the new detail.
- Select the insertion point for the new detail.
- Enter the detail description into the text editor.

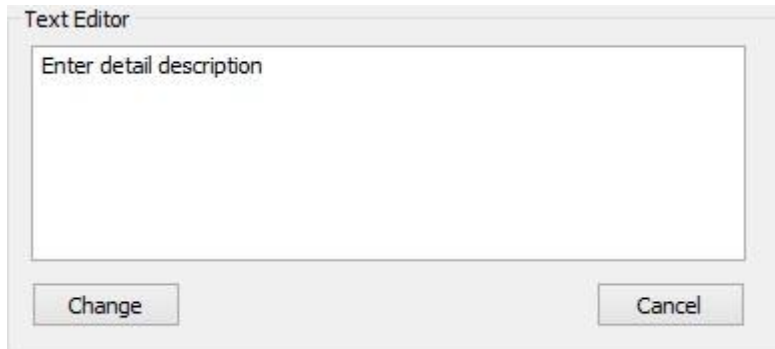

- Select 'Change'.

3.23 LA – Label All

Commands:

Global name:	_LABEL
Local name:	LABEL
Alias:	LA
Space:	Layout Space

Purpose:

- Used to label any selected joists, walls, trusses, etc.
- Used to update all text information on all paper space borders at once, e.g. if material thickness is changed on every frame at once, LA will update the member cutting list information in one go.
- When making major changes to frames in the Detailing Space, LA will update all the information in all the borders and reassociate the frames with the Model Space 3D.

Process:

- Ensure the border of the layout to be labelled is in focus on the screen. If in doubt, run 'V' and then the border number.
- Type LA then press Enter.
- Select entities to label or press Enter again to label all. Only the entities that are in the focus border will be able to be labelled.

Additional Information:

Wall, beam, truss and joist labels MUST NOT start with an 'X'. X is the default used for unlabelled frames.

3.24 LI – List Item

Commands:

Global name:	_FRAMING_LIST
--------------	---------------

Local name:	FRAMING_LIST
Alias:	LI
Space:	Layout and Detailing Space

Purpose:

Opens an editor dialogue box for most Steelwise entities that are selected. If an editor is not applicable to an entity, the standard CAD listing entity information window will open.

Process:

- Type LI then press Enter.
 - Select the entity to list.
- OR
- Double mouse click on an entity.
 - An editor dialogue box relevant to the item selected will open giving the user the option to make any changes.
 - Click on 'Amend' (or 'Change') to activate any changes. The 'Amend' button is made active after changes are made within the dialogue.
 - Multiple items can be selected and altered at once.
 - After clicking on 'Amend', and if the Change Prompts are not hidden, type in 'a' for 'all' to make the change to all of the selected items.

To select only common multiple items on a view that contains multiple different entity types and items that are on other layers:

- Type LI then press Enter.
- Select one instance of the item to list.
- Drag a fence over the total area containing all items to be listed.
- An editor dialogue box relevant to the items selected (based on the initial item selection) will open giving the user the option to make any changes.
- Click on 'Amend' to activate changes. The 'Amend' button is made active after changes are made in the dialogue.
- After clicking on 'Amend', and if the Change Prompts are not hidden, type in 'a' for 'all' to make the change to all of the selected items.

3.24.1 Bath Editor

3.24.2 Beam Editor

Beam Editor

Property	Value
[-] General Data	
System Name	FRAMECAD_FT_m
Beam Category	Webbed
Model Type	Default
Beam Name	Webbed Beam
Beam Label	
Zone Location	Zone Not Used
Beam Top RL	2440
Beam Base RL	2140
Redline Text	
Drafting Colour	50
Treats as Non Struct...	False
Detail This Item	Yes
Show in 3D Model	Yes
Text Height	180
Convert to panel	Press to Convert
Reset Labels	Press to Reset

Amend Cancel

Changing the Beam Top RL value will alter the Base Level RL according to the beam height value. Changing the Beam Base RL value will not alter the Top Level RL, it will only change the beam height value.

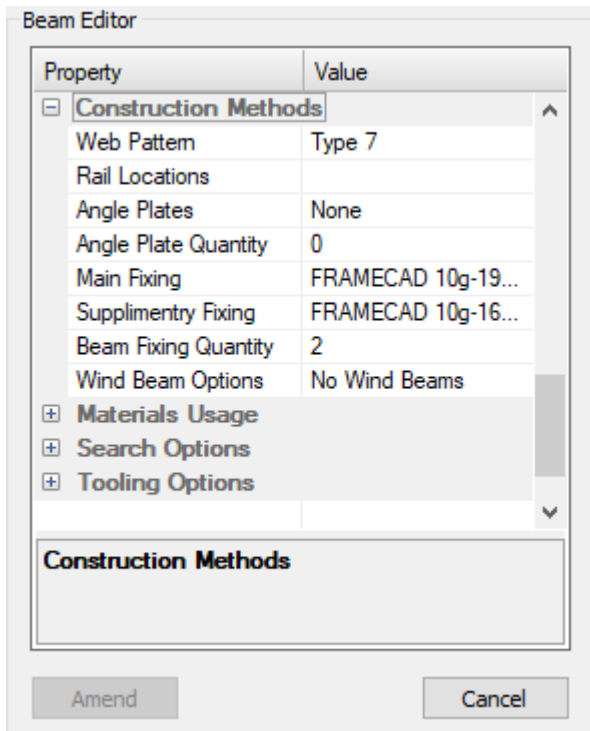
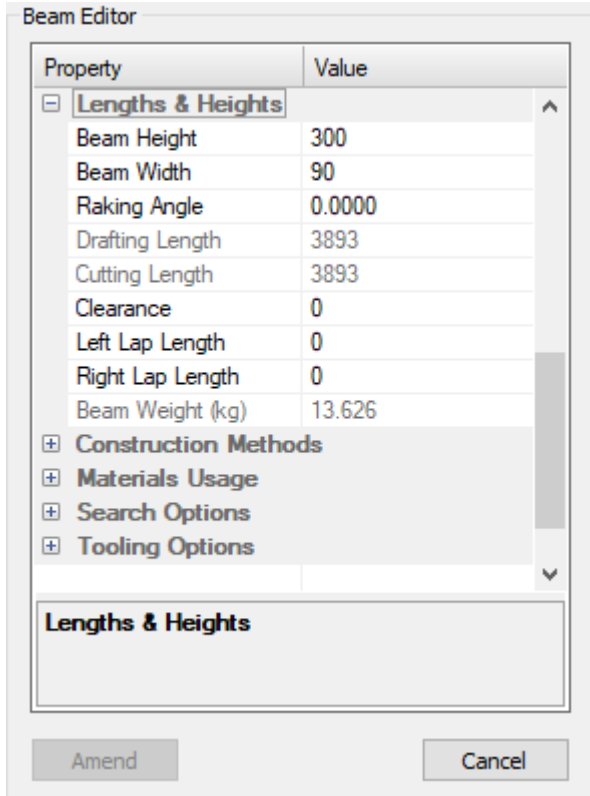

Wind Beam Option – Allows the user to add a Wind Beam (boxed stiffener plate) to the top or bottom or both top and bottom of the beam.

3.24.3 Brace Editor

Property	Value
Brace Information	
Brace Type	Strap Brace
Brace Material	Auto
Brace Quantity	Single
Brace Length	2032
X Contribution (kN)	5.078
Y Contribution (kN)	0.000
Racking Resistance ...	5.078
Overturning Resistan...	10.576
Overall Capacity (kN)	5.078

Keep Discard

Listing a brace provides the user with bracing values and limited editing options which vary depending on the type of brace being listed.

3.24.4 Fixings Details

Property	Value
Product Information	
Joint Type	Web Joint
Main screw type	FRAMECAD 10g-19mm (SJ)
Sub screw type	FRAMECAD 10g-16mm Flathead (SJ)
Drafting Colour	3
Qty of main fixings	2
Qty of sub fixings	2
Total qty of fixings used	4
Strengths	
Total capacity (kN)	9.572
Joint Load (kN)	3.673

Keep Discard

Product Information:

- Joint Type - Main, Web, Rail, Brace, Boxing

- Main screw type - this is the primary screw fixing
- Sub screw type - this is the secondary screw fixing
- Quantity of main fixings
- Quantity of sub fixings

Strengths:

- Total capacity - total capacity of fixing (kN or kip)
- Joint load - total load at joint (kN or kip)

3.24.5 Floor Member Editor (Webbed Joist)

General Information:

Property	Value
General Information	
System Name	FRAMECAD_FT_m
Member Name	WJ89095-500
Category	Webbed Joist
Member Usage	Joist
Member Type	Webbed Joist
Label	J1
Zone Location	Zone Not Used
Member Height	300
Member Width	90
Length Drawn	4000
Clearance Allowed	0
Nominal Weight (kg)	19.035
Layout Colour	
Reduced Level	2740
Redline Text	
Engineering Status	65%
Detail This Item	Yes
Show in 3D Model	Yes
Go to detailed beam	Click to go
Joist Spacing	600
Oncoming Web Align	False
Double Webs to Sup...	False
Hide Joist Labels	False
Text Height	180
Material Information	
Fixing Information	
Loading Information	
Deflection Limits	
Batten Information	
Tooling Options	
Search Options	

Amend Cancel

- System Name - Data File Name
- Member Name - Model
- Member Usage
 - End Bearer – This member sits on the perimeter of the floor layout and is perpendicular to the joists. They do not support any other members and are continuously supported.

- Side Bearer – This member sits on the perimeter of the floor layout and is parallel to joist layout. They do not support any other members and are continuously supported.
- Internal Bearer – This member is perpendicular to, and located somewhere between the ends of the joists at a pre-determined spacing as selected in the 'Layouts Information'. They do not support any other members and are continuously supported.
- Joist – This is a standard joist which support the floor only.
- Joist Beam – This is a joist that supports other joists.

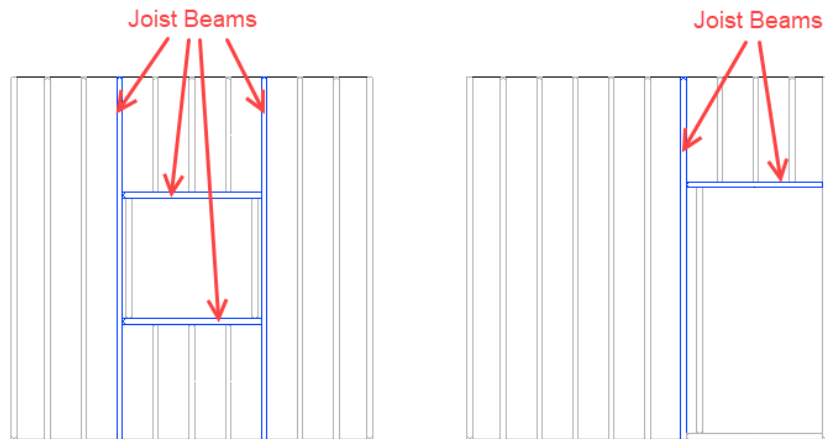

- Beam Bearer – This is defined as an End Bearer that supports Joists and Joist Beams, but spans between two or more supports, whereas an End Bearer is continuously supported.

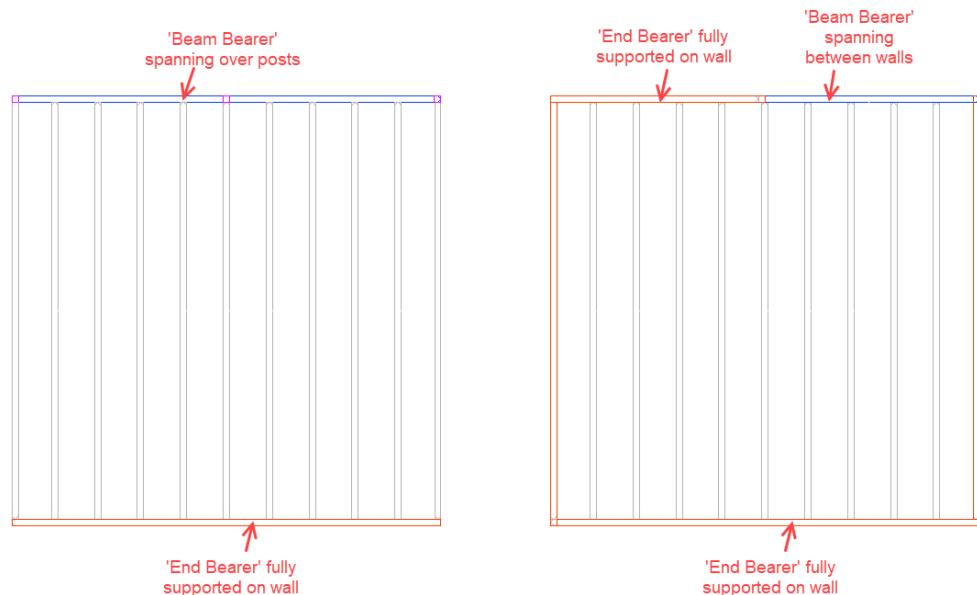

In the second example above, the End Bearer has been split into two members, so the unsupported portion can be defined as a Beam Bearer.

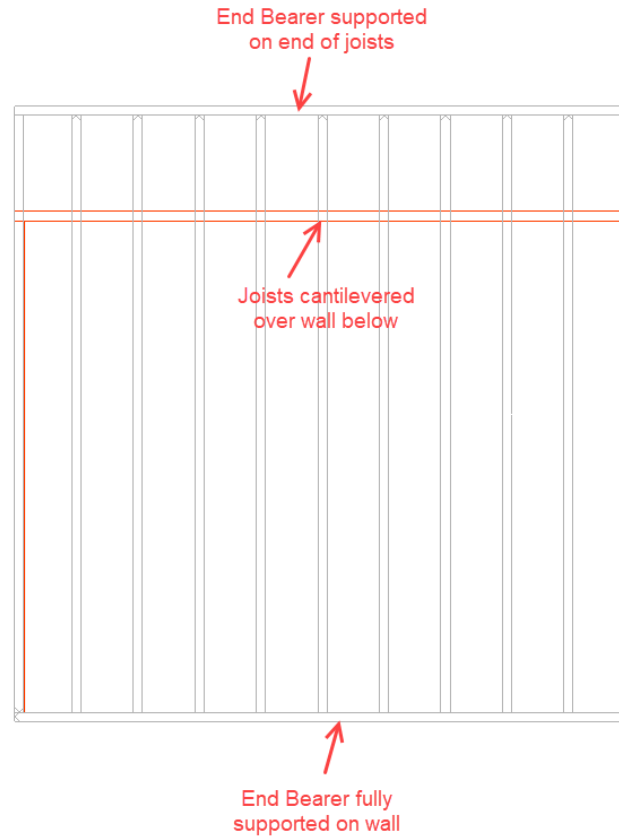

In the example above, the member on the cantilevered end of the joists will remain as an End Bearer because it is supported by the joists.

- Member Type - Webbed Joist or Unlipped Cee
- Label
- Zone Location (refer to the zone location description in Panel Properties Editor)
- Member Height - This value can only be changed for webbed joists.
- Member Width
- Length Drawn
- Clearance Allowed - The joist will be shortened by this distance.
- Nominal Weight - Approximate weight only.
- Layout Colour
- Reduced Level - Height from the base of the building to the top of the joist member
- Redline Text - This text is placed diagonally across the elevation in Detail Space and is shown in red.
- Engineering Status - This is only populated after the joists have been built (JJD).
- Detail This Item - If set to 'No', the joist will lose its label and will not export with JJD.
- Show In 3D - If set to 'No', the joist will not appear in the 3D view.
- Joist Spacing - Centre to centre distance as set in JSET.
- Oncoming Web Align - If set to 'True', vertical webs will be placed at oncoming joist locations.

- Double Webs to Supports - If set to 'True', double webs will be placed at support locations whenever a width is applied to a support line but only if that width is greater than 2x the member web width.
- Hide Joist Labels - Turns the joist label visibility off for viewing clarity.
- Material Information

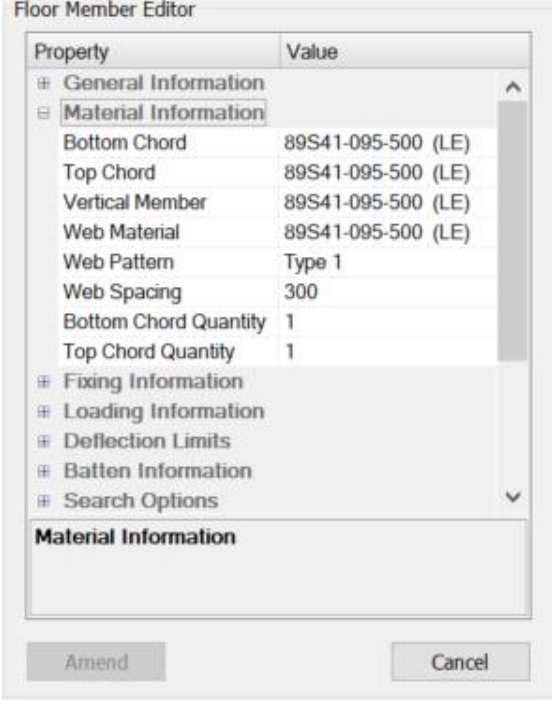

The screenshot shows the 'Floor Member Editor' dialog box. It features a table with 'Property' and 'Value' columns. The 'Material Information' section is expanded, showing the following properties and values:

Property	Value
Bottom Chord	89S41-095-500 (LE)
Top Chord	89S41-095-500 (LE)
Vertical Member	89S41-095-500 (LE)
Web Material	89S41-095-500 (LE)
Web Pattern	Type 1
Web Spacing	300
Bottom Chord Quantity	1
Top Chord Quantity	1

Below the table, there are sections for 'Fixing Information', 'Loading Information', 'Deflection Limits', 'Batten Information', and 'Search Options'. At the bottom of the dialog, there are 'Amend' and 'Cancel' buttons.

- Bottom Chord; Top Chord; Vertical Member; Web Material.
- Web Pattern - Choose from 11 different web patterns. Web pattern 1 and 2 will reduce
- Web Spacing
- Bottom Chord Quantity
- Top Chord Quantity

3.24.6 Gridline Editor

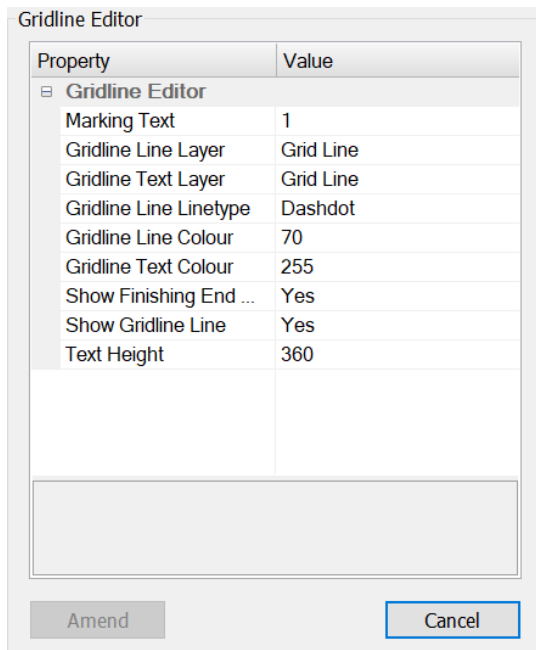

- Marking Text
- Gridline Line Layer
- Gridline Text Layer
- Gridline Line Linetype
- Gridline Line Colour
- Gridline Text Colour
- Show Finishing End Marker
- Show Gridline Line
- Text Height

3.24.7 Layout Title

When listing a title more options are available in the Sheet Label Editor including the option to change the default layout name.

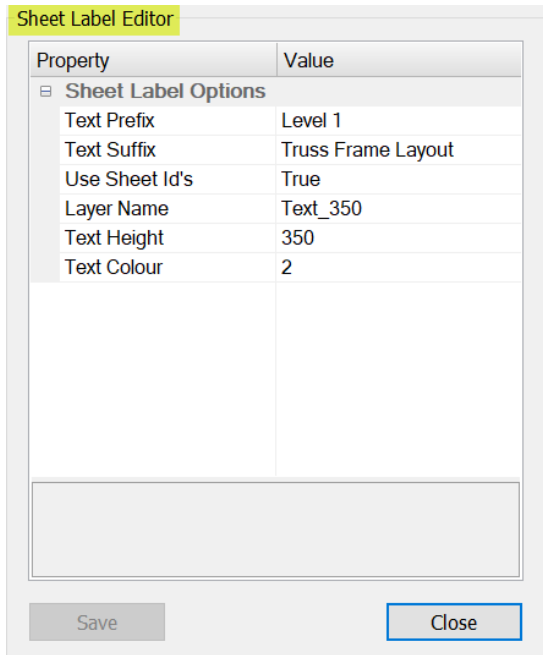

3.24.8 Opening Editor

Allows changes to be made to properties of an opening.

Opening Information:

- Library – This is the opening configuration that was used at the time that this opening was inserted into the panel. If a user defined opening was inserted, then UD or UW will show.
- Code – This is the code or window text label shown on the layout drawing. You may change this description if required.
- Head Location – This is the location of the opening head from the underside of the bottom plate to the underside of the header. Changing this value will change the sill height where possible.
- Overall Height – This is the height from top of the sill to underside of header for windows, or from the underside of the bottom plate to the underside of the header for doors. Changing this value will change the sill height where possible.
- Sill Height – This is the height of the sill measured from the underside of the bottom plate to the top side of the sill. Changing this value will also change the opening height where possible.
- Overall Width – This is the width of the opening measured from inside of jamb stud to inside of jamb stud. Changing this value changes the width based on the centreline of the opening.
- Allowed Clearance – This is the clearance that has been allowed for on each side of the opening. This value is only used when fitting openings to brickwork and serves no other purpose.
- Fitted to Brickwork – This shows whether the user has fitted the opening to suit brickwork (PFB).
- Engineering Status –
 - This field shows the current engineering status of the opening.
 - Prior to walls being engineered, the status will be set to 'Unknown'. Once the walls have been through the PCB, PPD or have been updated using the PUA command, then the status will change to 'Passed'. If any of the parameters under

'Construction Methods' is manually altered, then the status will change to 'Amended'.

- If you wish to change an amended opening back to its original passed state, click on the drop down and change to 'Unknown'. In the detailing space, the opening will revert back to its passed state; in the layout space you will need to PUA the job to finalise the process.
- Reset all Labels – Resets all opening labels back to default e.g. accidentally deleted labels will be restored.

Locations:

An opening can be moved in the elevation view by listing it and changing the distance in the Location area. The Start location is the distance from the left-hand end of the panel to the left side of the opening. The End Location is the distance from the right-hand end of the panel to the right side of the opening. The same option is available in the plan view.

- Start Location –
- End Location –

Construction Methods:

- Head Type –
- Web Pattern –
- Lintel Materials –
- Lintel Quantity (only visible when a lintel material is selected) –
- Jack Stud Spacing – Allows the header jack stud spacing to be changed. Set as 'Default', this will use the nominal stud spacing. The user can overwrite the word 'Default' with a required spacing value.

Note that it will only work for web patterns that have vertical members in them. Also, this only applies to the header jacks and not the sill jacks.

Once applied, the opening header will automatically re-engineer.

- Web to Openings -
 - For loadbearing walls, this is the minimum width of an opening before diagonal webs are placed. Openings below this value will only have vertical jack studs as per a non-loadbearing wall opening.
 - For non-loadbearing walls, this is the maximum width of an opening before diagonal webs are placed. Openings below this value will only have vertical jack studs.
- Maximum Head Depth –
- Head Split Depth –
- Split to Base –
- Mullion Top Location – The mullion option allows an opening to be split into two openings horizontally. This value is to set the top of the horizontal mullion.
- Mullion Depth (only visible when a value is entered into 'Mullion Top Location') – This is the depth from the top of the mullion down to the underside of it.
- Mullion Webs (only visible when a value is entered into 'Mullion Top Location') – This option allows for diagonal webs to be placed inside the mullion if required.
- Framing Option – This option is only applicable to walls that are imported from an external source, e.g. Revit (via Revlink). If an opening gets imported through with wall frames e.g. a ducting or pipe or electrical opening, the user can choose to ignore framing around that opening.

Construction Options:

- Top Noggin
- Bottom Noggin
- Head Check Calcs
- Sill Check Calcs

- Head Stiffener –
- Sill Stiffener –
- Align Head Studs – Allows the user to activate web alignment to trusses in opening headers. This only applies to web patterns that have vertical members.

Note: Studs will only be placed where point loads are. Use the Stud Array (PSA) command if any other stud placement is required.

- Maximum Web Spacing – This value changes to suit the 'Jack Stud Spacing' in the 'Construction Methods' section. It can be overwritten to apply a maximum value.
- Bottom Plate Cutout –
- Minimum Studs Left/Right –

Dynamic Sizing:

This allows the user to add top bottom and side clearances to their openings. Multiple openings can be edited at once.

One method of selecting multiple openings is to run the IL (Isolate Layer) command, select an opening, then right click to confirm selection. That way, it will make it a little easier to single out window from door openings when running the LI (List) command.

Load Information:

3.24.9 Post Editor

Do Not Detail – This prevents the post from being labelled or sent to the Panel Builder (PPD).

3.24.10 Panel Properties Editor

General Information:

Panel Properties Editor

Property	Value
[-] General Information ^	
System Name	FRAMECAD_FT_m
Model Type	M11 89S 0.75 G500
Panel Label	L1
Zone Location	Zone Not Used
Drafting Width	89
Actual Width	89
Panel End Clearance	0
Length Drawn	5000
Maximum Length	7500
Drafting Colour	1
Redline Text	
Detail This Item	Yes
Show in 3D Model	Yes
Convert to beam	Click to convert
[+] Height Information	
[+] Loading Information	
[+] Stud Data	
[+] Construction Information	
[+] Notching Information	
[+] Materials Information	
[+] Fixings Information	
[+] Calculated Loads	
[+] Search Options	
General Information	

Amend Re-Code Cancel

- System Name - The system data file to be used.
- Model Type - The member profile, gauge, steel grade to be used.
- Panel Label - This label is generated by the software.
- Zone Location - When Listing (LI) walls, trusses or joists, the listing dialogue box shows an option in General Information called 'Zone Location'. This allows a selection of entities (walls, trusses or joists) to be grouped into areas.

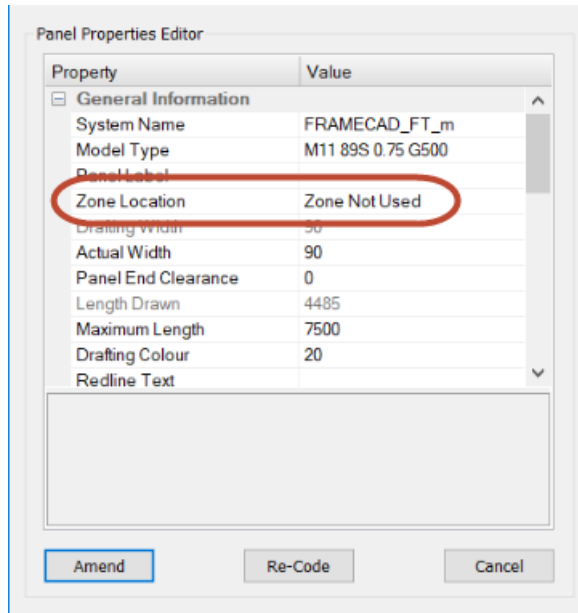

To use this, select and list (LI) a group of walls, trusses or joists, then in the Zone Location, overwrite 'Zone Not Used' with a label that best describes the location of the selected frames, e.g. Unit1. Select the next set of frames and type in Unit2. When you perform a PPD, TTD or JJD, these frames can then be filtered by zone when building. The zone label will be shown in front of the panel or joist label in the elevation views.

In PSET – Options – Labelling Option Information, you can set 'Restart Zone Numbering' to 'False' to have continuous numbering through all zones, i.e. all numbers will only be used once and not repeated.

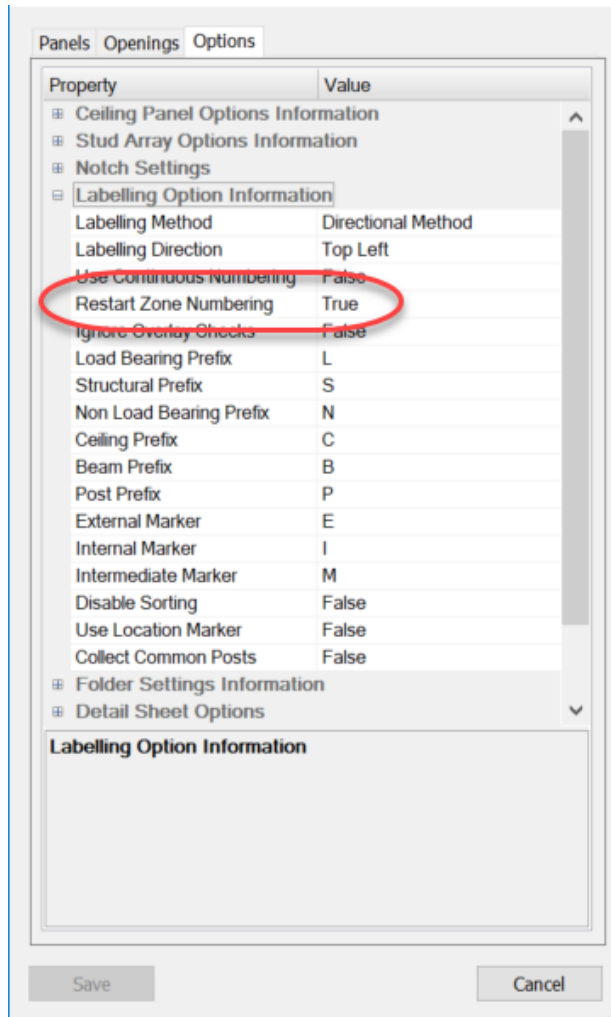

Note: Zones cannot start with the characters 'X' or 'Z' and the first character cannot be a number. Zone text length must also be greater than 2 characters long and is limited to 6 characters. Spaces will be eliminated.

This option is ideal for large commercial or multi-unit buildings.

- Drafting Width - The width of the panel as drawn on the layout.
- Actual Width - Actual width of the steel profile.
- Panel End Clearance - The distance to shorten a wall when it is sent to the Panel Builder (PPD). This distance is applied to both ends of the panel and the end studs are moved in by this distance. The maximum value allowed is 5mm which would shorten the wall by an overall total of 10mm. Openings, beam pockets, etc. within approximately 100mm of the end of the panel will move by this value. This is to eliminate the possibility of members overlapping each other. It is advised that the user double checks components at the ends of shortened panels prior to manufacture to ensure the results are what they are expecting.
- Length Drawn -
- Maximum Length -
- Drafting Colour -
- Redline Text -

- Detail This Item -
- Show in 3D Model -
- Convert to Beam -
- Go to Detailed Panel -

Height Information:

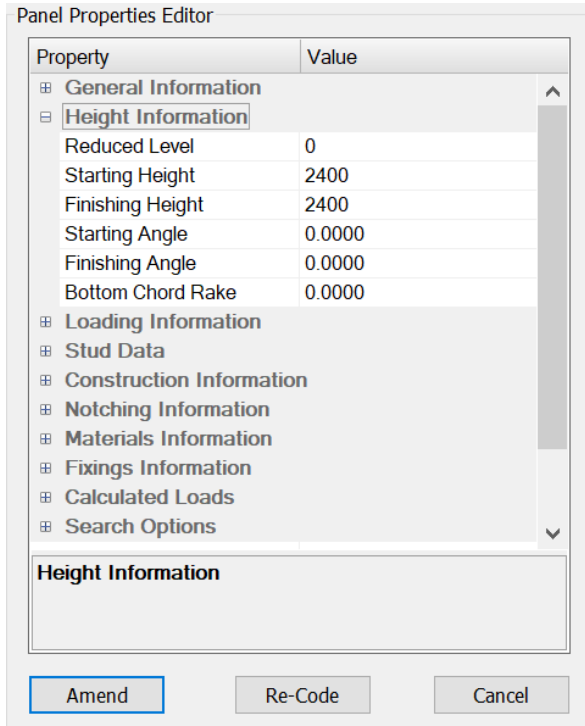

- Reduced Level - height to the bottom of the panel
- Starting Height - the overall frame height at the left-hand end
- Finishing Height - the overall frame height at the right-hand end
- Starting Angle - top plate raking angle from the left-hand end
- Finishing Angle - top plate raking angle from the right-hand end
- Bottom Chord Rake - bottom plate raking angle from the left-hand end

Loading Information:

Panel Properties Editor

Property	Value
▣ General Information	
▣ Height Information	
▣ Loading Information	
Vertical Load	SHEET
Usage Type	Load Bearing
Wind Speed (AS 4055)	N2
Location	External
Floor Type	Concrete
Extra Truss Span	0
Extra Joist Span	0
Extra Snow Load (kPa)	0.00
Wall Mass (kPa)	0.11
Structural Tolerance	800
▣ Stud Data	
▣ Construction Information	
▣ Notching Information	
▣ Materials Information	
▣ Fixings Information	
▣ Calculated Loads	
▣ Search Options	

Loading Information

Amend Re-Code Cancel

- Vertical Load - roof load as determined in the Truss Settings (TSET)
- Usage Type - Loadbearing, Non-loadbearing or Structural
- Wind Speed - as determined in the Border Settings (BSET)
- Location – used for calculating wind bracing (PCB).

External or Internal – This is automatically set by the walls physical location as determined by the software. This can be manually altered to suit.

Mixed – If a wall is a mix of internal and external, then self-weight is altered to suit internal wall linings on both sides and horizontal wind is decreased. This option needs to be manually set by the user.

- Floor Type - Concrete, Steel or Timber. This setting only determines what hold-down fixings are to be used as set in the data file.
- Extra Truss Span - this allows the user to add truss loads that are not present on any referenced Truss Layout drawings. NOTE: Tributary loaded width applied to wall is one-half of the extra span.
- Extra Joist Span - this allows the user to add floor joist loads that are not present on any referenced Floor Joist Layout drawings. NOTE: Tributary loaded width applied to wall is one-half of the extra span.
- Extra Snow Load - this allows the user to add snow loads that are not pre-set in the Truss Settings (TSET).
- Wall Mass - this is the self-weight of the wall unlined. The user can add the weight of claddings, if required, by clicking on the ellipsis button to the right of the value.
- Structural Tolerance - this determines the allowable gap between the bottom of a wall and the top of the wall below before loads are no longer transferred.

Stud Data:

Panel Properties Editor

Property	Value
Stud Data	
Stud Arrangement	Single Absolute
Actual Stud Spacing	600
Nominal Stud Spacing	2000
Stud Restraint Height	0
Noggin Heights	1220
User Noggin Heights	
Service Holes	300 450
Truss Tolerance	300
Joist Tolerance	300
Front Align	False
Back Align	False
Double Jamb Studs	1250
Jamb Stud Gap	1
Jack Stud Gap	1
Initial Stud Spacing	600

Stud Data

Amend Re-Code Cancel

- Stud Arrangement – Select from the options available in the drop-down list. Selecting 'Auto' will reset the stud data. The Actual and Nominal Stud Spacing will change to 0. After selecting 'Amend', the stud arrangement, actual stud spacing and nominal stud spacing will be recalculated.
- Actual Stud Spacing – This is the value as set in the data file. If the Nominal Stud Spacing drops below this value, then the Actual Stud Spacing will drop to suit.
- Nominal Stud Spacing – This is the value that is calculated by the software and does not allow for top or bottom plate strength.
- Stud Restraint Height – This is particularly useful with taller walls that have a floor, ceiling or roof structure attached to the side of the wall. The restraint height is the distance from this restraint to either the top plate or bottom plate, whichever is the greater, and the stud spacing and arrangement is calculated based on that height.
- Noggin Heights – This height is automatically calculated as a single row of nogs evenly spaced between the top and bottom of the wall up to 1399mm to the centre of the noggin (as set in the standard data file). Once the wall exceeds 2798mm, the wall height will be divided into two rows of noggins.
- User Noggin Heights – The user can enter in a value to add extra noggins. Heights are to the centre of the noggin.
- Service Holes – The heights shown are the heights that are set up in the data file. The user can enter in a value to add extra service holes or clear existing ones.
- Truss Tolerance – This means that when placing a stud under a truss, if another stud is found within this distance, then a stud will not be placed under that truss, unless the top plate bending check determines that a stud is required.
- Joist Tolerance – This means that when placing a stud under a joist, if another stud is found within this distance, then a stud will not be placed under that joist, unless the top plate bending check determines that a stud is required.
- Front Align – Allows studs to align with trusses or joists that connect to the front face of a wall. Note: Truss/Joist tolerance must be set to "0" for this option to work.

- Back Align – Allows studs to align with trusses or joists that connect to the back face of a wall. Note: Truss/Joist tolerance must be set to “0” for this option to work.
- Double Jamb Studs – Allows the user to always include a minimum of double jamb studs to openings greater than the value specified.
- Jamb Stud Gap – Gap between multiple jamb studs. This setting does not affect back to back common wall studs.
- Jack Stud Gap – Gap between jack stud and jamb stud. This also sets the gap for back to back common wall studs.
- Initial Stud Spacing – Allows the user to decrease the initial stud spacing from whatever is set in the data file.

Most of these default values can be set in the data file – please create a ticket in MyFramecad to request any data file changes.

Construction Information:

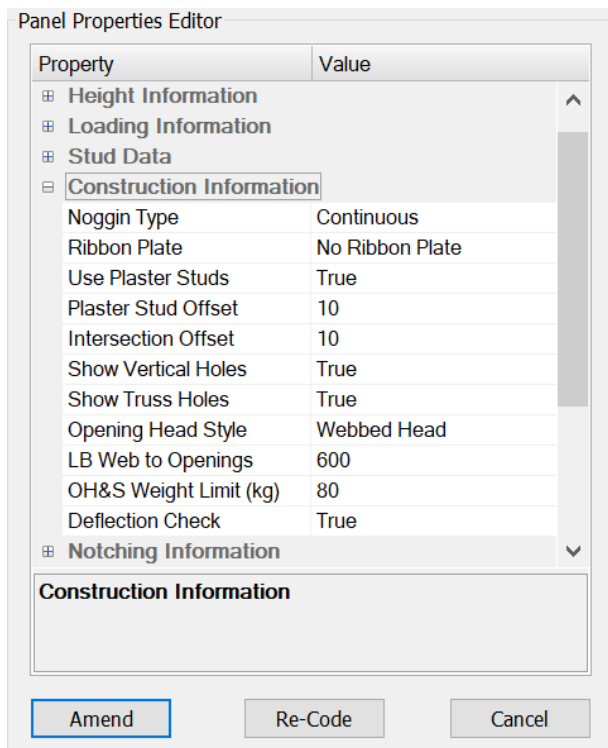

The screenshot shows the 'Panel Properties Editor' dialog box. The 'Construction Information' section is expanded, showing the following properties and values:

Property	Value
Noggin Type	Continuous
Ribbon Plate	No Ribbon Plate
Use Plaster Studs	True
Plaster Stud Offset	10
Intersection Offset	10
Show Vertical Holes	True
Show Truss Holes	True
Opening Head Style	Webbed Head
LB Web to Openings	600
OH&S Weight Limit (kg)	80
Deflection Check	True

At the bottom of the dialog box, there are three buttons: 'Amend', 'Re-Code', and 'Cancel'.

Notching Information:

Panel Properties Editor

Property	Value
General Information	
Height Information	
Loading Information	
Stud Data	
Construction Information	
Notching Information	
Start Height	0
Start Length	0
Finish Height	0
Finish Length	0
Materials Information	
Fixings Information	
Calculated Loads	
Search Options	

Notching Information

Amend Re-Code Cancel

Materials Information:

Panel Properties Editor

Property	Value
Construction Information	
Notching Information	
Materials Information	
Bottom Plate	89S41-055-500 (LE)
Top Plate	89S41-055-500 (LE)
Opening Heads	89S41-055-500 (LE)
Opening Sills	89S41-055-500 (LE)
Noggins	89S41-055-500 (LC)
Solid Noggins	89S41-055-500 (LC)
Studs	89S41-055-500 (LC)
Solid Braces	89S41-055-500 (LC)
Webbing	89S41-055-500 (LC)
Blocking	89S41-055-500 (LE)
Bath Rail	89S41-055-500 (LC)
Ribbon Plate	None
Fixings Information	

Materials Information

Amend Re-Code Cancel

Fixings Information:

Panel Properties Editor

Property	Value
▣ Loading Information	
▣ Stud Data	
▣ Construction Information	
▣ Notching Information	
▣ Materials Information	
▣ Fixings Information	
Load Bearing Fixing	FRAMECAD 10g-19mm XDrive
Non Load Bearing Fixing	FRAMECAD 10g-19mm XDrive
Strap Brace End Fixing	FRAMECAD 10g-16mm Flathead
Strap Brace Intermediate Fixing	FRAMECAD 10g-16mm Flathead
Single Lintel Fixing	FRAMECAD 10g-16mm Flathead
Double Lintel Fixing	FRAMECAD 10g-16mm Flathead
Supplimentry Fixing	FRAMECAD 10g-16mm Flathead
▣ Calculated Loads	
▣ Search Options	

Fixings Information

Amend Re-Code Cancel

Calculated Loads:

Panel Properties Editor

Property	Value
▣ Fixings Information	
▣ Calculated Loads	
Dead Load (kN/m)	0.00
Roof Live Load (kN/m)	0.00
Floor Live Load (kN/m)	0.00
Wind Up (kN/m)	0.00
Wind Down (kN/m)	0.00
Horizontal Wind (kPa)	0.86
Snow Load (kN/m)	0.00
Self Weight (kN/m)	0.26
TP Reaction Down (kN/m)	0.00
TP Reaction Up (kN/m)	0.00
BP Reaction Down (kN/m)	0.31
BP Reaction Up (kN/m)	0.00
▣ Search Options	

Calculated Loads

Amend Re-Code Cancel

Search Options:

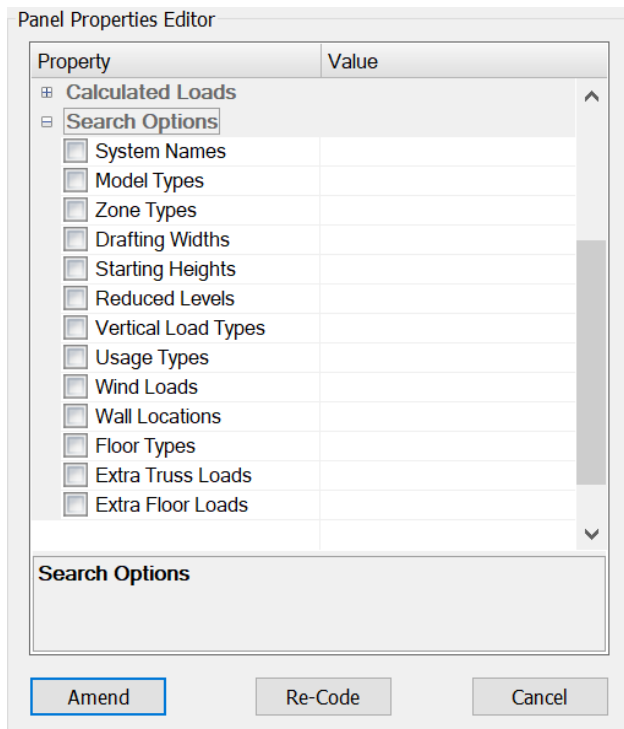

3.24.11 Reference Point Editor

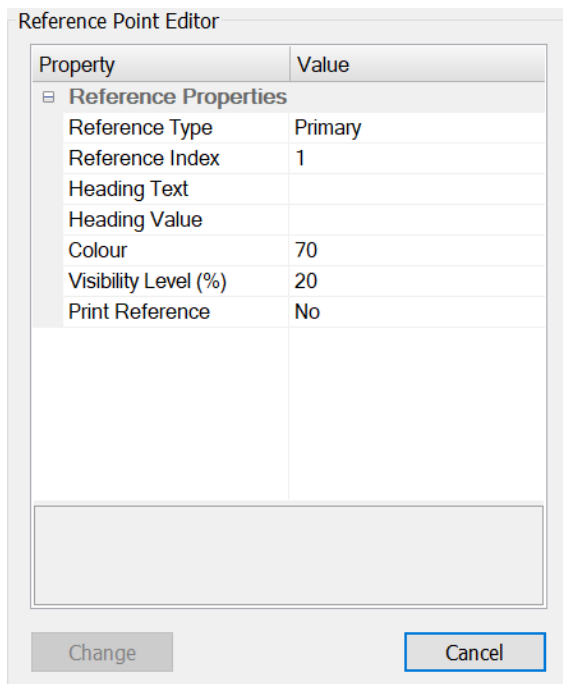

- Reference Type - Primary or Secondary
- Reference Index
- Heading Text - Adds extra information above the leader line
- Heading Value - Adds extra information below the leader line
- Colour

- Visibility Level (%)
- Print Reference - Default is 'No'

3.24.12 Section Marker Editor

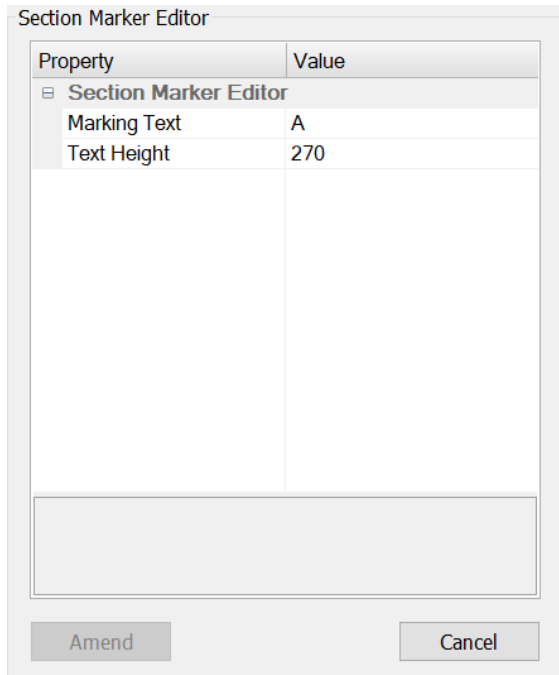

Property	Value
<div style="border: 1px solid gray; padding: 2px;"> ▣ Section Marker Editor </div>	
Marking Text	A
Text Height	270

- Marking Text
- Text Height

3.24.13 Smart Panel Editor

3.24.14 Stick Editor (v11.1 onwards only) – previously Member Editor

This is used to edit “stick” members in the detail sheet (frame elevations) and is only applicable to jobs that have been created in Structure v11.1 onwards. The only additions are the ‘Drawing Options’.

3.24.15 Stud Editor

If the stud location is to be fixed, select 'True' from the drop-down list next to 'Location Fixed'.

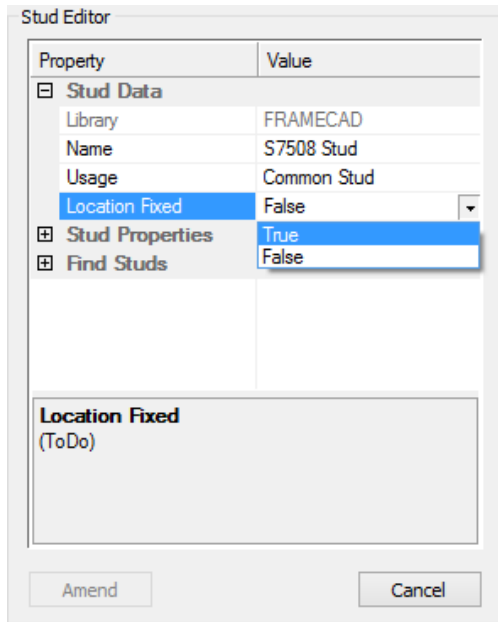

3.24.16 Tool Action Editor

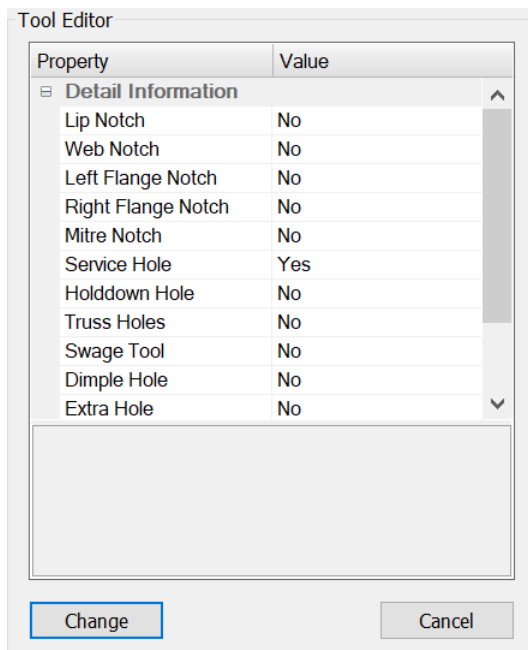

Lists the tool type that was used on Explicit Tool input. This can then be changed in the editor if required.

3.24.17 Truss Editor

Trusses can be listed from the layout or from the Truss Builder (by double clicking on the truss in the list).

General Information:

Truss Editor

Property	Value
General Information	
System Name*	FRAMECAD_FT_m
Truss Type	Standard Truss
Model Name	Default
Zone Location	Zone Not Used
Truss Orientation	Left Handed
Roof Load	SHEET
Wind Speed (AS 4055)	N2
Ground Snow Load (kPa)	0.00
Truss Label	Nil
Drafting Colour	
Redline Text	
Engineering Status	Unknown
Go to detailed truss	Click to go
Detail This Item	Yes
Show in 3D Model	Yes
Construction Information	
Truss Spacing	818
Span Information	
Pitch Information	
Height Information	
Eave Information	
Web Information	
Materials	
Fixings	
Editing Tools	
Effective Length Factors	
General Information	

Keep Discard

- System Name – As set in TSET
- Truss Type – As defined on input
- Model Name – As set in TSET
- Zone Location – This allows a selection of trusses to be grouped into areas.
- To use this, select and list a group of trusses, then in the Zone Location, overwrite 'Zone Not Used' with a label that best describes the location of the selected frames, e.g. Unit1. Select the next set of frames and type in Unit2. When you perform a TTD, these trusses can then be filtered by zone when building. The zone label will be shown in front of the truss label in the elevation views.
- In TSET – Options – Labelling Option Information, you can set 'Restart Zone Numbering' to 'False' to have continuous numbering through all zones, i.e. all numbers will only be used once and not repeated.
- Note: Do not start the zone location description with 'Z' or 'X' or a number. Description length must be greater than 2 characters long and is limited to 6 characters. Spaces will be eliminated.

- This option is ideal for large commercial or multi-unit buildings.
- Truss Orientation – ‘Right Handed’ trusses will display only for LC (B2B) half trusses on hip ends and only if that option is set to be used in the data file, otherwise, all trusses will be displayed as ‘Left Handed’.
- Roof Load – As set in TSET
- Wind Speed – As set in BSET
- Ground Snow Load – As set in TSET
- Truss Label – As set when using LA
- Drafting Colour – As defined in the data file
- Redline Text – User option – will be displayed in truss elevation view
- Engineering Status – Changes from ‘Unknown’ after trusses have been built (TTD)
- Go to detailed truss – If trusses have already been built, clicking on the button to the right of ‘Click to go’ will jump directly to the selected truss elevation in the truss detailing tab.
- Detail This Item – Item to be detailed or ignored
- Show in 3D Model – Item to be displayed in model view or ignored

Construction Information:

- Truss Spacing – By default, this is the actual spacing as determined by the software on TD (Truss Layout) input.
- End Web Setback (v11.1.6.0) – Allows for the end vertical web at the high end of half trusses or the cut-off end of stop ended trusses to be edited to a set distance from the end of the truss.

Span Information:

Pitch Information:

Height Information:

Eave Information:

Web Information:

Materials:

Fixings:

Editing Tools:

Effective Length Factor:

- Effective Length (Kx)
- Effective Length (Ky)
- Torsional Length (Kt)
- Horizontal Restraint (Lh)
 - This allows the horizontal top chord restraint spacings to be modified in situations where the hip end rafters or half truss top chords don’t run over the horizontal top chord of the truncated truss, e.g. where the horizontal top chord is flush with the roof plane.

- By default, a calculated value is applied to truncated trusses that have been input automatically using the JD command. If a truncated truss of any type is manually input using the ADD command or if a truss is listed and changed to any truncated type truss, then this value will be reset to zero which is the default setting that uses the roof batten spacing and the following warning message will be displayed:

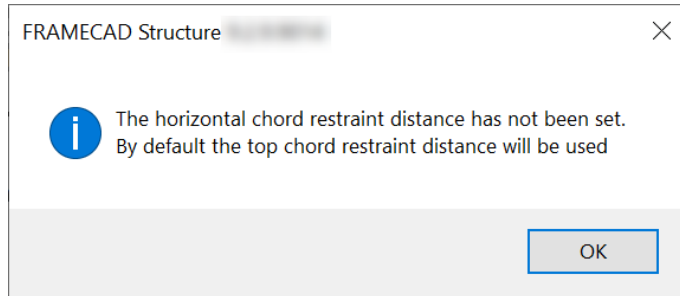

- You can then change the restraint value if required, as described above.

Split in Height

- Split in Height - Click on the button to the right of 'Click to Split' to activate the split.
- Split Height - This is the height required to split the trusses.
- Split Gap - This is the gap required between the base truss (truncated truss) and the top hat truss (saddle truss) to run horizontal restraint members.
- Split Pitch - This is the pitch that will be applied to the top hat truss.

Additional Information:

* Alt + right click on 'System Name' to save user settings.

3.25 MV – Move View

Commands:

Global name:	<code>_MOVEVIEW</code>
Local name:	<code>MOVEVIEW</code>
Alias:	<code>MV</code>
Space:	Layout and Detailing Space

Purpose:

Moves entities from one border to another.

Process:

- Type MV then press enter.
- Select the entities that you wish to move then enter.
- The display will zoom out to show all borders.
- Select anywhere within the border that you wish to move the selected items to.

3.26 QT – Quick Text Input

Commands:

Global name:	_QUICK_TEXT
Local name:	QUICK_TEXT
Alias:	QT
Space:	Layout and Detailing Space

Purpose:

To quickly add commonly used text to plans - generally plan labels.

Process:

- Type QT then press Enter.
- Select the required text from the Quick Text Options dialogue box predefined list.
- Click on any line on the title box to place the text in the recommended location (or select a different location if required).
- Dialogue Box Options:
 - Category: Select a category from the drop down menu for more text. Click on the hash # button next to Category to add or amend categories.
 - Add Text: Type in any required text and click on this button to add it to the selected category.
 - Insert: Inserts any selected text onto the plan.
 - Delete Text: Highlight text in the list and click on this button to delete.

3.27 REF – Reference Point Input

Commands:

Global name:	_REF_POINT
Local name:	REF_POINT
Alias:	REF
Space:	Layout Space

Purpose:

References one plan to another for the purpose of transferring loads from one layout to the other (specifically from trusses or joists through to walls).

The software is basically a 2D program however with the 'Reference Point' system, it has all the functionality of a 3D program. By inserting a 'Reference Point' on the wall layouts and corresponding 'Reference Points' on a truss layout or floor layout, the software will see this as an overlay, thus loads will be transferred automatically.

The first point inserted is called the 'Primary' point and subsequent points are called 'Secondary' points. The primary point is the point where the structure is built from. When the software needs to transfer loads, or build 3D views etc, the primary point is where they are built from, and all entities associated with secondary points are transferred to the primary point location.

For the 'Reference Point' system to work correctly there are four rules which must apply:

1. The first rule is that there can only be one 'Reference Point' within a border.

2. The second rule is that there must be a minimum of two 'Reference Points' for each reference number used.
3. The third rule is that there can only be one 'Reference Point' number for each structure.
4. The final rule is that each 'Reference Point' must be placed in a corresponding point within a border to the primary 'Reference Point'.

The 'CHECK' command will check and warn if any of the rules one to three are broken, however the software cannot check the fourth rule, so it is up to the user be aware and be careful.

Process:

- Type REF then press Enter.
- Select a location on the wall framing plan to place the primary marker which is common on all other plans (make sure end snap is on). When the first 'Reference Point' is inserted into the drawing, it is automatically a primary marker and will be given an ID of one.
- Right click to repeat command to insert a secondary marker. All subsequent markers inserted will be secondary markers given the same ID number.
- Additional Information:
- The ID number will not change until such time as a new primary 'Reference Point' is inserted. To insert a new primary point, press 'P' before inserting the 'Reference Point'. The ID number will be automatically incremented. There is no way to add a specific ID number however, the ID number can be edited through the 'LI' command.
- When a 'Reference Point' is inserted, it is placed on the layer 'Defpoints'. This is a special layer that **does not print** therefore 'Reference Points' are only visible to the operator. The primary reference marker is shown in a bright green colour and secondary reference markers are shown in a dull green colour.
- Note: It is essential that the DEFPOINTS layer is visible at all times. Items drawn on this layer never get printed.
- **Ensure that the reference marker and number lie on or within the border.** If it sits outside the border, it will not be recognised. The ideal recommended location is at the bottom left-hand corner of the building being detailed – this way, if the building layout gets moved for some reason within the border, then the reference marker will get moved with it while remaining in the correct location on the building. Remember: the reference marker does not get printed.
- The primary reference marker can also be placed in the model space. This is useful when working with IFC models and you wish to see the 3D viewed in that exact location.

3.28 RESETALL – Reset Registry

Commands:

Global name:	_RESETALL
Local name:	RESETALL
Alias:	resetall
Space:	Layout and Detailing Space

Purpose:

Deletes all the historical Steelwise information from the computer's registry, thus all settings will be set back to default as if it was a brand-new install on a clean computer.

Process:

Type RESETALL then press Enter.

Additional Information:

Some software issues may be resolved by activating RESETALL.

3.29 REV – Revision Cloud

Commands:

Global name:	_REVISION_CLOUD
Local name:	REVISION_CLOUD
Alias:	REV
Space:	Layout and Detailing Space

Purpose:

To draw in a revision cloud where required.

Process:

- Type REV then press Enter.
- Select one corner to start the revision cloud.
- Select the opposite corner to finish.
- The revision cloud will be input as a rectangular shape.

3.30 SECT – Section Properties and Capacities

Commands:

Global name:	SECT
Local name:	_SECT
Alias:	SECT
Space:	Layout and Detailing Space

Purpose:

This tool shows the properties and capacities of any profile as entered in by the user.

Process:

- Type SECT then right click or press Enter.
- Select the appropriate Design Code.
- Select the appropriate Section Profile. The user must have some knowledge of the various section types if they wish to use this tool.
- Type in the appropriate size parameters.
- Click on the 'Calc' button to update the properties and capacities.

3.31 SETREF – Set 3D Marker in Model Space

Commands:

Global name: _SETREF

Local name: SETREF

Alias: SETREF

Space: Layout Space

Purpose:

Allows the user to place a locating reference mark in Model space by selecting a point on the Layout space. This allows the user to copy and paste entities in exactly the right location from the layout to the model.

Process:

- Ensure that the REF reference markers are placed in the layout space plans to ensure that the layouts are all linked.
- Staying in the layout space, type SETREF
- Click on the required location on the plan. A 3D Marker will be placed in that location on the border which contains the primary reference marker - if one exists. A corresponding 3D Marker will be placed in the Model space.
- Type COPYBASE. You will be prompted to select the base point. Select the corner of the entity which intersects with the 3D Marker.
- Go to the Model space tab and ensure the 'Node' snap is set.

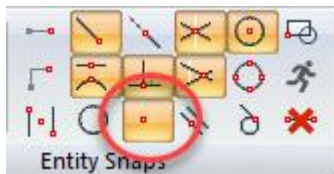

- Paste the entity using ctrl+v and click on the 3D Marker.

3.32 SHOW – Show Start End of Entities and Show Engineering Failures

Commands:

Global name: _SHOW

Local name: SHOW

Alias: SHOW

Space: Layout and Detailing Space

Purpose:

Shows the starting end of an entity and also shows any truss or wall lintel engineering failures.

Process to show start end:

- Type SHOW then press Enter.

- Select the member to query.
- An asterisk is placed at the start end.

Process to show engineering failures:

- Type SHOW then press Enter.
- Press Enter again to show engineering failures.
- An asterisk is placed over all failed trusses or openings.

3.33 SL – Code Support Line

Commands:

Global name:	_TRUSS_SLINE
Local name:	TRUSS_SLINE
Alias:	SL
Space:	Layout and Detailing Space

Purpose:

Codes a line as a support line. Its main purpose is to enable the software to see where the trusses or joists are being supported. The support line intelligence is transferred through to the truss/joist builder as a support point on each truss/joist.

Process:

- Type SL then press Enter.
- Select the lines to be coded.
- Additional Information:
- If you select a polyline, it will be converted to ordinary lines.

3.34 SN – Cursor Snap Angle at 45°

Commands:

Global name:	_SN
Local name:	SN
Alias:	SN
Space:	Layout and Detailing Space

Purpose:

Rotates the cursor crosshair snap angle to 45°

Process:

- Type SN then press Enter.

3.35 SP – Spool Print

Commands:

Global name:
Local name: SPOOL_PRINT
Alias: SP
Space: Layout and Detailing Space

Purpose:

Displays the Print dialogue box so you can print the current drawing.
Prints layouts or elevations from layout space.

Process:

Type SP then press Enter.

Dialogue Box Options:

Printer Name - Select the printer and view its details.

Orientation - Select the paper orientation from the printer setup.

Paper Size - Select the paper size from the printer setup.

Pen Library -

Process:

- Selected Window - Drag a window out to the required print area.
- Auto Borders - Select this option to print all borders.
- Current Screen - Select this option to print current screen.
- Selected Borders - Click on borders that are required to print (borders will be printed in the same order as selected; dragging a window to select borders may not print in the order expected).
- Quantity - Either type in a number or use the up or down arrows to change.
- Select GO to start the print or select Cad Print to go to the standard IntelliCAD print dialogue box.

3.36 SS – Steel Profiles

Commands:

Global name: _STEEL_PROFILES
Local name: STEEL_PROFILES
Alias: SS
Space: Layout and Detailing Space

Purpose:

Adds a steel profile to your drawing.

Process:

Type SS then press Enter.

Select the profile type then the member from the Steel Profiles Selection dialogue box.

Change the alignment method and scale if required.

Click on Draw then select the location to add the steel profile to.

3.37 TCNC – Text/Lines to CNC

Commands:

Global name:	_TEXT_CNC
Local name:	TEXT_CNC
Alias:	TCNC
Space:	Detailing Space

Purpose:

Use this command to send additional text that is manually added to an elevation to the .xml file during the CNC operation.

This command can also be used to send lines through to the .xml file.

Process:

- Type TCNC then press Enter. The command can also be found under 'Miscellaneous' in the Steelwise drop down menu.
- Select the required text. This will only work for standard text input and will not work for multiline text.
- And/or:
- Select the required lines. This will only work for lines and will not work for polylines or any other shapes.

3.38 VER – Software Version

Commands:

Global name:	_VERSION
Local name:	VERSION
Alias:	VER
Space:	Layout and Detailing Space

Purpose:

Displays all the version information relating to the installed software.

Displays the Licence Information.

Process:

- Type VER then press Enter.
- The following information is displayed:
 - 'Cad Module Version' - This is the version of the IntelliCAD platform.
 - 'Initial IRX Version' - When a drawing is started, and on the initial save, the current version of Steelwise that is being used is saved with the job.
 - 'Last IRX Version' - When a drawing is last saved, the current version of Steelwise that is being used is saved with the job.
 - 'Current IRX Version' - This is the version of Steelwise that is currently installed. This is the number that should be quoted whenever asked for a Steelwise version number

by FRAMECAD support staff. This number also appears at the top of all Steelwise dialogue boxes.

- 'Platform' - This is the Operating System bitrate that is loaded on the computer (64-bit or 32-bit).
 - 'Operating System' - This is the version of the Windows OS that is loaded on the computer.
 - 'Expiry Date' - Softkey licence expiry.
- Scroll down to view other features enabled in your licence.

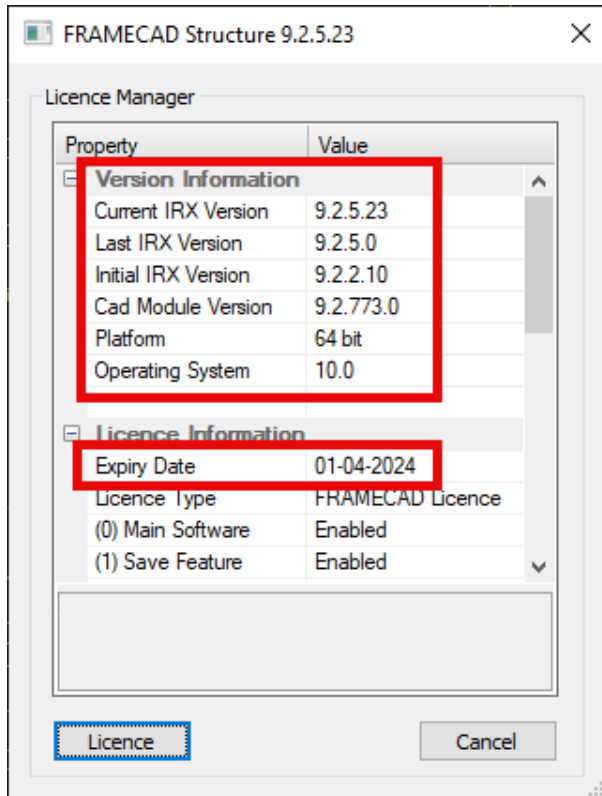

- Softkey licence expiry date also appears in the Command Bar when the program is first opened.

```
Command:
Command:Loaded FRAMECAD Structure IRX Module
Command:
Command: Software expires 01-04-2024
Rendering support loaded.
Raster image support loaded.
```

- Click on the 'Licence' button at the bottom left to open the Licensing dialogue box.

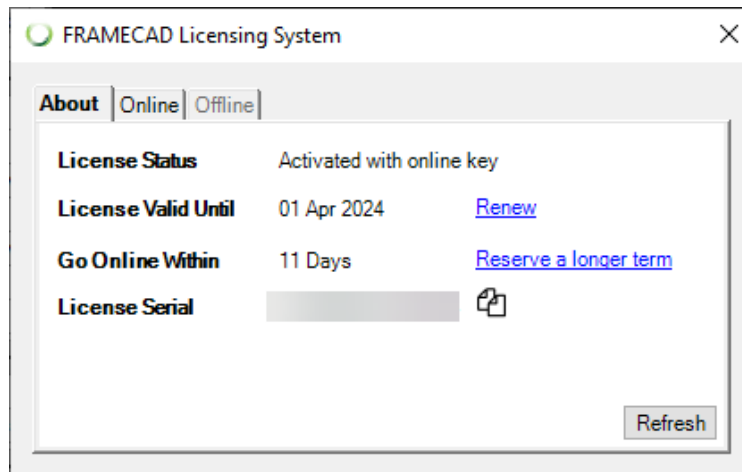

4 Exports

4.1 ACNC – Common CNC Export

Commands:

Global name:	_CNCALL
Local name:	CNCALL
Alias:	ACNC
Space:	Layout and Detailing Space

Purpose:

Creates separate XML files from all detailing space tabs at once.

Process:

- From within any space within the job, type ACNC then press Enter.
- Wait for process to finish.
- Upon completion of this routine, the 'CNC Files' are deposited in the 'C:\Users\username\Documents\CNC' folder.

4.2 CNC - Common CNC Export

Commands:

Global name:	_ CNC
Local name:	CNC
Alias:	CNC
Space:	Detailing Space (Layout Space for deep C joists)

Purpose:

Creates an XML file from the current detailing space tab ready for sending to the rollforming machine.

The XML file for deep C joists is created straight from the joist layout plan.

Process:

- Go to the required detailing space tab or the layout plan for deep C joists.
- Type CNC then press Enter.
- Wait for process to finish.
- Upon completion of this routine, the 'CNC File' is created in the 'C:\Users\username\Documents\CNC' folder.

4.3 IFC - IFC Export

Commands:

Global name:	_IFC
--------------	------

Local name: IFC
 Alias: IFC
 Space: Model Space

Purpose:

Creates an Industry Foundation Classes (IFC) file which is used by Building Information Modelling (BIM) programs (e.g. Tekla, Revit, SAP, etc.)

Process:

- In the 'BSET' command, go to the 3D Options in the 'Options' tab and select the type of IFC you will be creating. Some trial and error may be required when selecting these options for other programs.

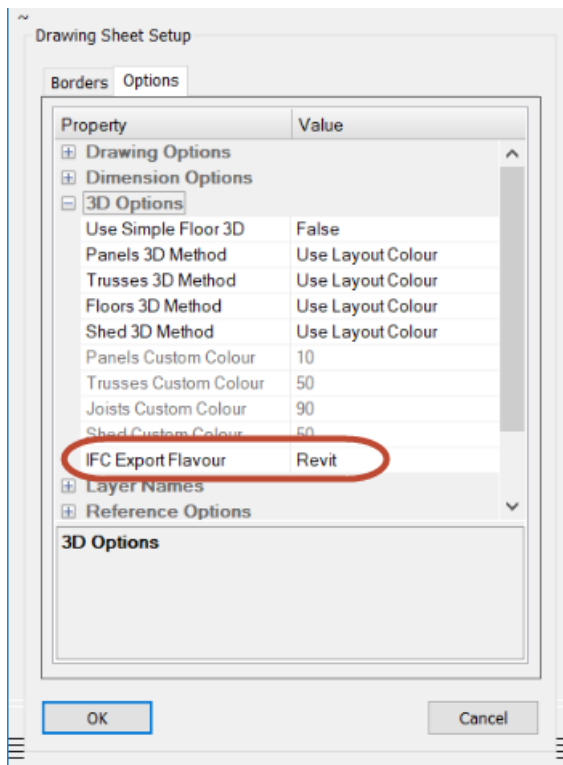

- Create a 3D model using the 'A3D' command in the 'Model' tab

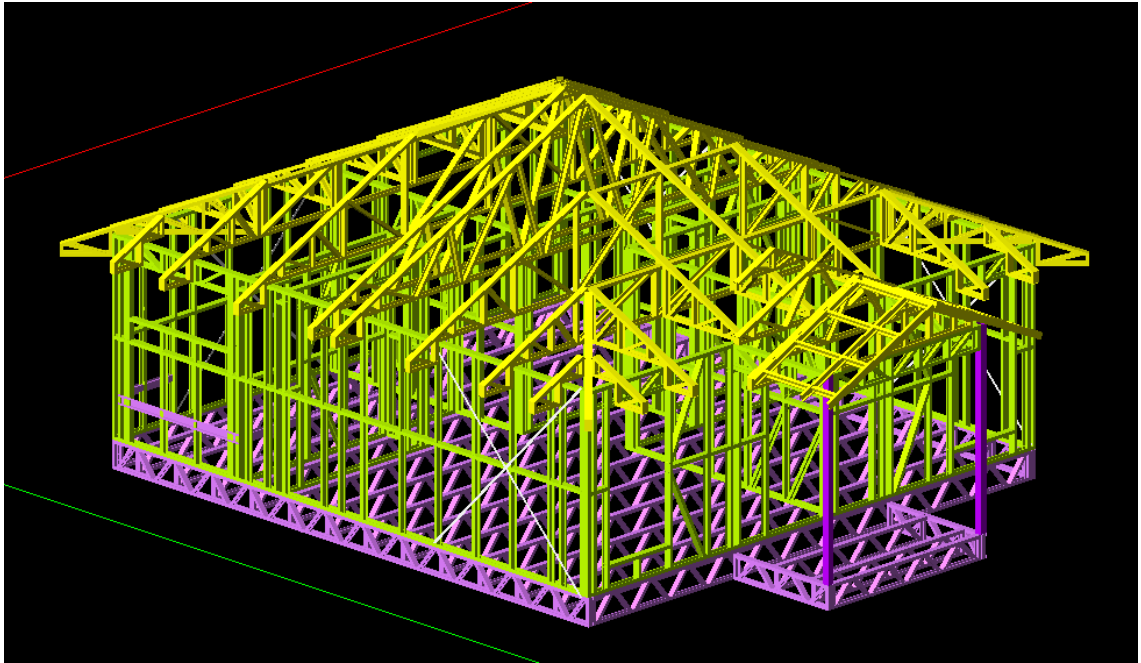

- From the model space, type IFC then right click or press Enter.
- The IFC file is created in ../Documents/CNC
- You can now open your IFC with the software you created the model for.

Additional Information:

Currently, hot rolled steel beams will export as long as they are detailed, i.e. sent to CAD from PPD. Posts will export straight from the 3D as long as they have been input using one of the BeamsPosts data files (see BSET – Options – Drawing Options to set the correct beams and posts data file usage for your region).

Gridlines can be exported in the IFC by using the C3D (CopyModel) command to copy them from the layout space to the model space. However, note that not all applications are capable of displaying gridlines from the IFC file.

4.4 PDF - PDF Export

Commands:

Global name:	_PDFSPOOL
Local name:	PDFSPOOL
Alias:	PDF
Space:	Layout and Detailing Space

Purpose:

To export views to a pdf file.

Process:

- Type PDF then right click or press Enter.
- Select required views to export from the Tables list in the Export to PDF dialogue box.
- Change any other parameters if required.

- Press 'OK' to export.

Additional Information:

When viewing PDF's, sometimes the fonts don't view correctly because the computer or device does not have the required true type fonts installed. In this situation you will need to tick on the Embed and/or Convert TTF options when creating the PDF.

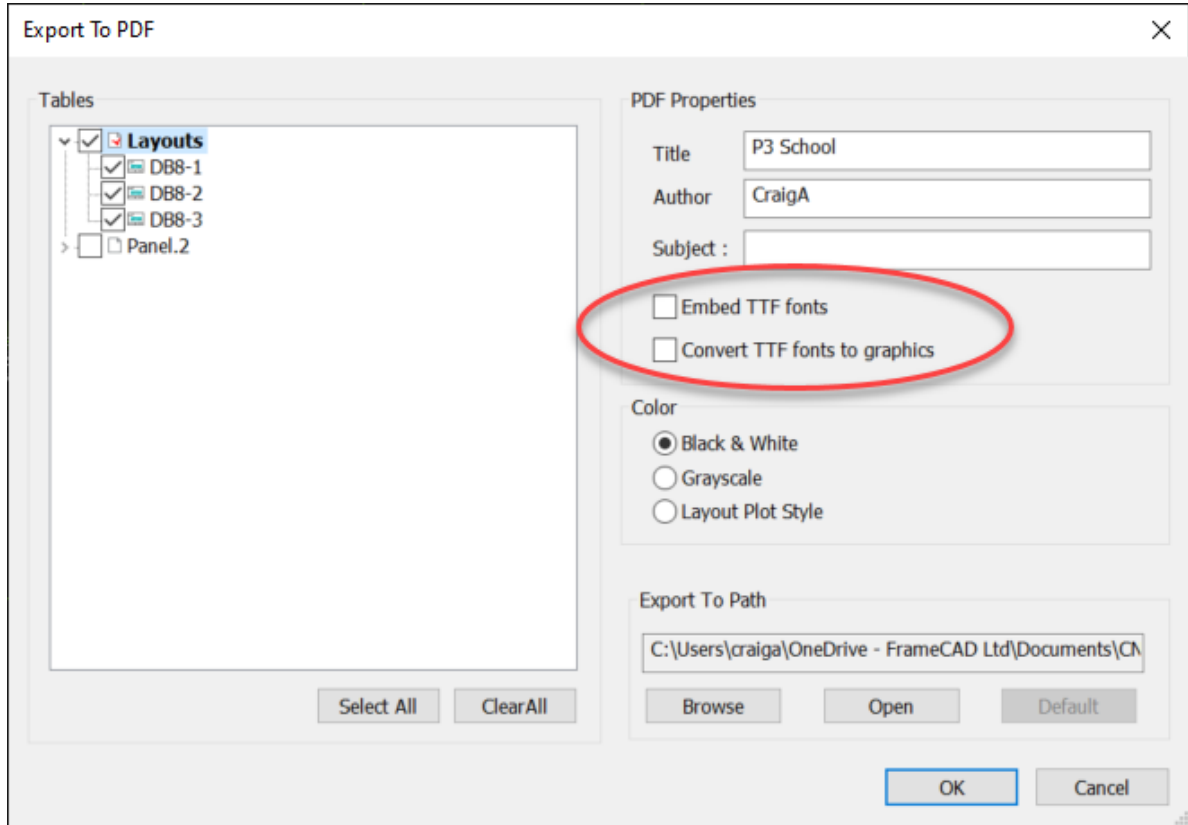

Please note that doing this will increase the file size.

4.5 RFY – Machine File Export

Commands:

Global name:	_ RFYEXPORT
Local name:	RFYEXPORT
Alias:	RFY
Space:	Layout and Detailing Space

Purpose:

Creates an RFY file ready for sending to the roll forming machine.

Note: The RFY output for deep C joists is created straight from the joist layout plan, therefore JJD is not required.

Process:

- Type RFY then press Enter – this opens the Export RFY dialog box.

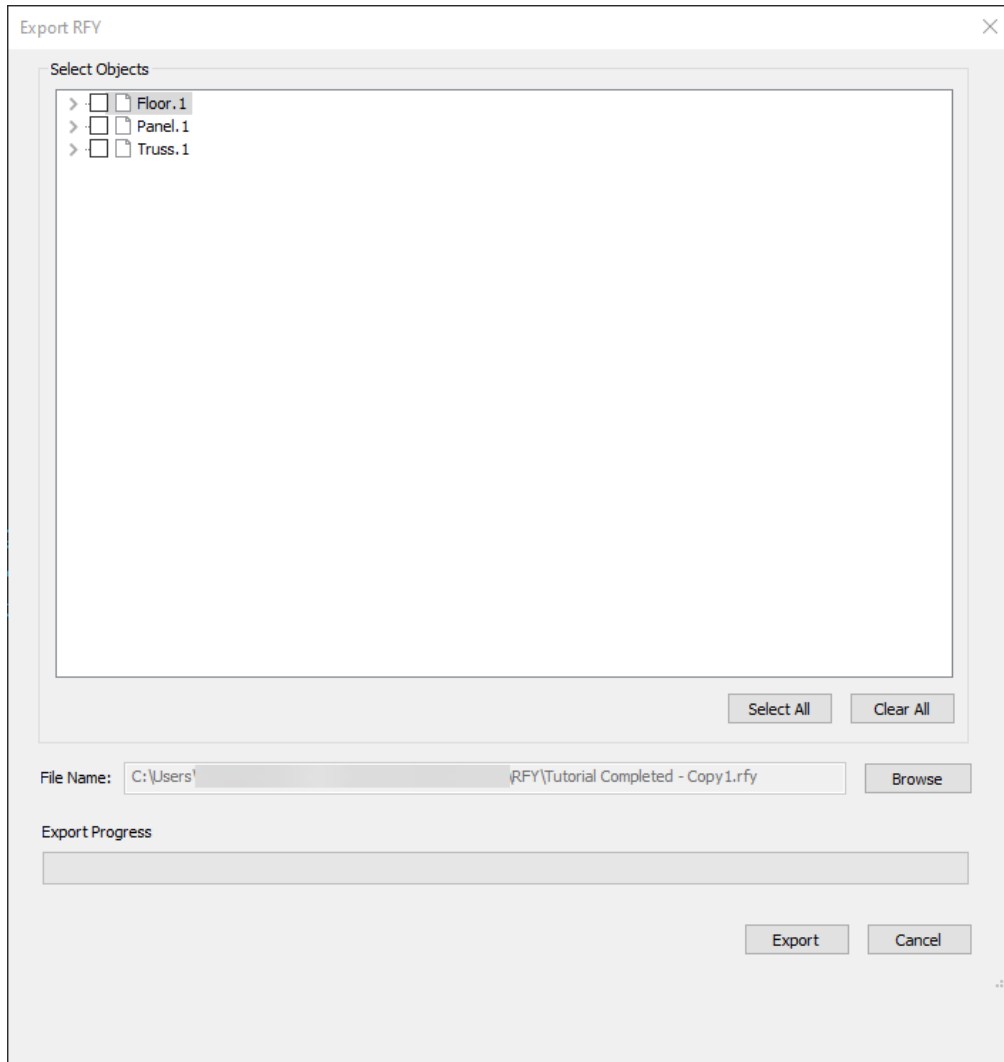

- Select the required tabs/frames to export.
- Edit the required filename and location if required.
- Click on Export to create the RFY file.

Additional Information:

- All RFY export options that were in Detailer can now be found in BSET – Options – Export Options.
- Detail sheet tabs and Frames within those tabs can be moved around by clicking and dragging to change the sort order.

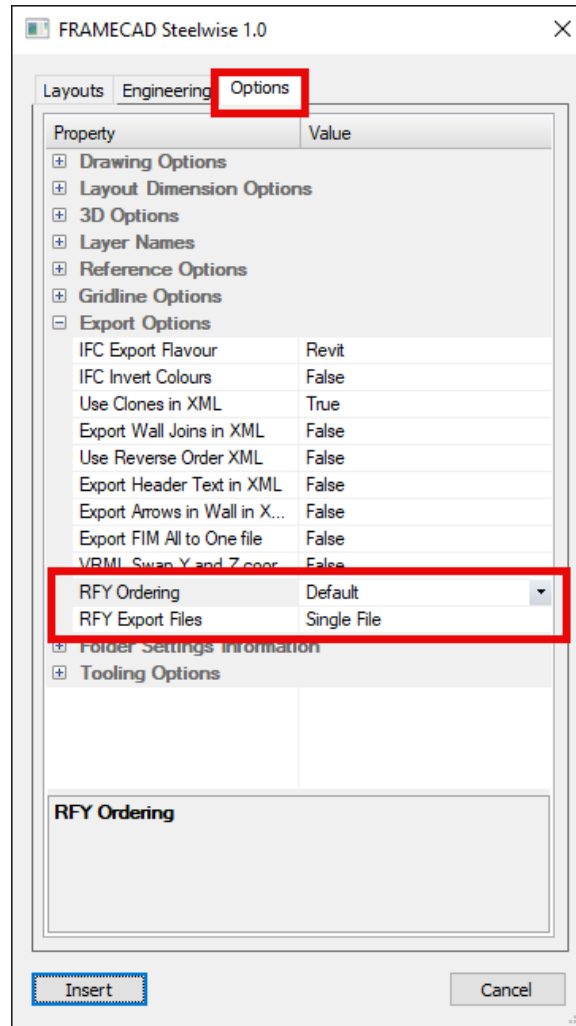

<ul style="list-style-type: none"> ▪ RFY Ordering 	<p>Default – Material exported in order from top left of frame to bottom right.</p> <p>Plates First – Horizontal members</p> <p>Studs First – Vertical members</p> <p>Assembly Priority – For walls, this will export the top plate first; then nogs and studs up to the first opening; then opening material; then nogs and studs to the next opening; etc; then bottom plate.</p>
<ul style="list-style-type: none"> ▪ RFY Export Files 	<p>Single File – All material will be exported in the one RFY file. The roll forming machines Factory software will then filter out any material that exists in the file that is not set up to be run through that machine. This allows for the one file to be used in all machines as long as they are setup to filter.</p> <p>By Section – Different material sections will be split into separate RFY files.</p>

5 Wall Framing Commands

5.1 AB – Auto Brace

Commands:

Global name: _AUTO_BRACE
 Local name: AUTO_BRACE
 Alias: AB
 Space: Layout Space

Purpose:

Places K-Bracing on a panel layout based on the parameters set in PSET.

Process:

- Open PSET and go to the Auto Brace Options
- Set the frequency options to your requirements. This value will place a maximum number of braces in that wall type if there is a sufficient number of stud bays to do so.
- The 'Minimum Wall Height' will not allow braces to be placed in any wall less than or equal to this value.
- Click on 'Save' or 'Cancel'
- Ensure the wall layout border is in focus.
- Type AB then press Enter.
- Once the braces have been placed, make any required edits.
- Then run the PUA command again to reposition and correctly orientate the studs to suit.

5.2 Defined Door Input Commands

Commands:

Global name:
 Local name:
 Alias: As per list below
 Space: Layout Space

Purpose:

To insert door openings based on the actual door leaf size (actual physical width of door component).

Process:

The following commands are used in conjunction with the parameters set in the PSET – Windows options. When a door leaf size is entered into the relevant command, the set clearances are added to create the correct trim opening size in the wall frame.

Command	Type	PSET Openings Settings
---------	------	------------------------

AR	Archway Opening (Square Set)	
CS	Cavity Slider	Cavity Sliding Door
ED	External Door	External Hung Door
FS	Face Slider	Face of wall sliding door
PA	Passage Door	Internal Hung Door
R1	Robe Door x1	Hinged Robe Doors - Single Width Factor
R2	Robe Door x2	Hinged Robe Doors - Double Width Factor
R3	Robe Door x3	Hinged Robe Doors - Triple Width Factor
S2	Internal Slider x2	Sliding Robe Doors - Double Width Factor
S3	Internal Slider x3	Sliding Robe Doors - Triple Width Factor
S4	Internal Slider x4	Sliding Robe Doors - Quad Width Factor

5.3 LP - Load Path

Commands:

Global name:	<code>_SHOW_LOAD</code>
Local name:	<code>SHOW_LOAD</code>
Alias:	<code>LP</code>
Space:	Layout Space

Purpose:

To show the referenced load paths of trusses or joists down onto walls below.

Process:

- Ensure reference markers are present on plans. See REF - Reference Point Input.
- Ensure wall layout border is in focus.
- Type LP then press Enter. Layout will zoom to extents.
- Select border containing supported truss or joist layout. Truss/joist load paths are indicated by lines.
- Type LP then press Enter to erase load path lines.

Additional Information:

Lines coloured orange indicate that the loads are being transferred correctly.

Lines coloured red indicate that no loads are being transferred. Generally, this indicates that the height settings are incorrect, i.e. the heights are greater than +/-100mm from one plan to another.

Note: If walls are set as "Structural", then the truss or joist lines will show as being red. The loads are still being transferred but only as evenly distributed loads, not as concentrated loads.

This is purely a visual representation of the load paths and is not a required step of the load transfer process. Loads are only transferred once the reference markers have been placed and the wall engineering has been activated using either the PCB, PPD or PUA commands.

5.4 PAB - Auto Break Panel

Commands:

Global name:	_PANEL_AUTO
Local name:	PANEL_AUTO
Alias:	PAB
Space:	Layout Space

Purpose:

Automatically break panels at optimum frame junction locations only while taking into account the maximum wall length setting. If the distance between junctions is greater than this length, no break will occur along this section of wall.

Method:

Type PAB then enter.

5.5 PBN - Bath Noggin

Commands:

Global name:	_PANEL_BATH
Local name:	PANEL_BATH
Alias:	PBN
Space:	Layout Space

Purpose:

Used to insert a bath or shower as a rectangular object which in turn automatically inserts a wall noggin at the specified height.

Process:

5.6 PBS - Build Studs

Commands:

Global name:	_PANEL_STUD
Local name:	PANEL_STUD
Alias:	PBS
Space:	Layout space only

Purpose:

Generates or regenerates studs in the wall frames with no engineering considered.

Process:

Type PBS then press Enter.

Additional Information:

All studs (except for PSA or locked studs) will be regenerated.
To re-engineer and rebuild studs, use the PUA command.

5.7 PCB - Calculate Bracing

Commands:

Global name:	_PANEL_WIND
Local name:	PANEL_WIND
Alias:	PCB
Space:	Layout Space

Purpose:

Calculates the bracing requirements for wall framing and allows the user to insert bracing elements, wind force markers and racking resistance markers, creates a bracing plan and produces a bracing report.

Process:

Inserting Braces

Note: Make sure the truss and floor layouts have been completed before proceeding with this stage of the Wall Detailing Process as roof and floor loads must be applied to the walls.

Note: Bracing should not be inserted until the 'Reference Points' markers have been placed on all wall framing, floor framing and truss layout plans. For the bracing calculations to be accurate, the applied loads must all be known.

- Ensure the wall framing layout is in focus on the screen.
- Type PCB and press Enter.
- Look at the 'Shortage X and Y' figures.
- If the 'Shortage X and Y' values are less than the 'Wind Force X and Y' values, this usually means that there are other bracing options selected. Go to 'Bracing Options' section and select or de-select whatever is or is not required.

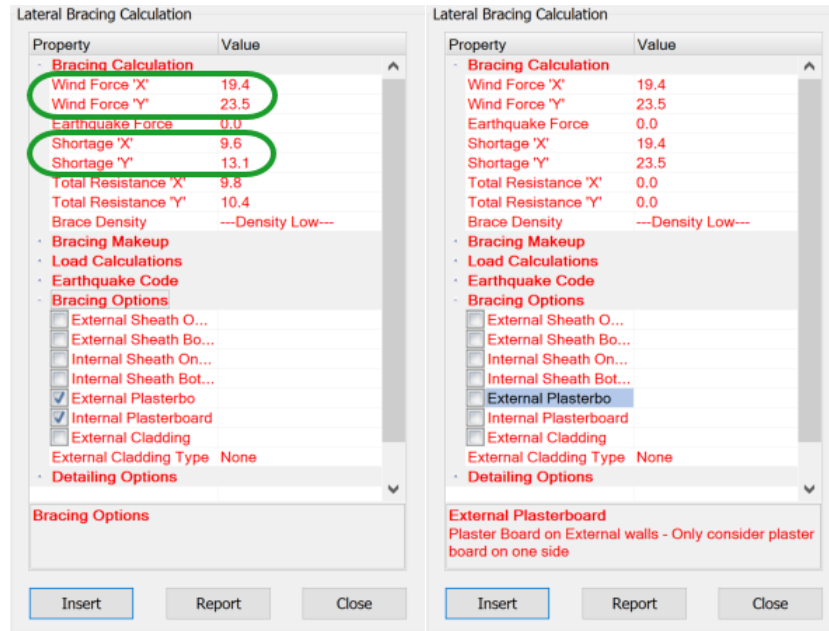

- Click on 'Insert Brace' or use the command - Panel Insert Brace (PIB) to insert braces. Return for Setup to set required Brace Type. Refer to PIB – Insert Brace for more detailed brace input and editing information.
- Check PCB periodically to see remaining number of bracing requirements in each direction. Add more bracing until the 'Shortage' figures read zero in both the 'X' and 'Y' directions.

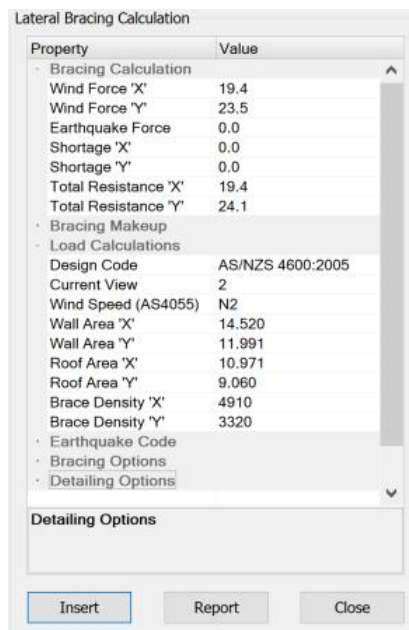

Creating a Bracing Plan

- To create a Bracing and Racking Resistance Plan, ensure that the Wall Layout Plan is in focus on the screen, then re-activate Panel Calculate Brace (PCB).
- In the PCB form, go to Detailing Options and select 'Create Bracing Plan' then click on 'Insert'. The plan will 'zoom to extents' to display all the borders
- Select an empty border to create the bracing plan in.

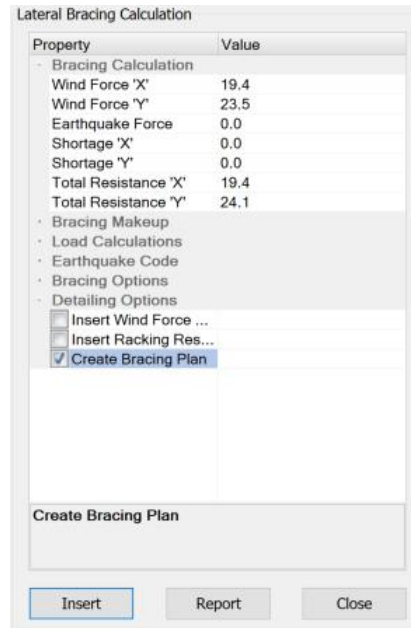

Creating a Bracing Report

- To create a Bracing Report, ensure that the Wall Layout Plan is in focus on the screen, then re-activate Panel Calculate Brace (PCB).
- Click on the 'Report' button at the bottom of the dialogue box.

5.8 PD - Wall Input (Panel Draw)

Commands:

Global name:	_ PANEL_TRACE
Local name:	PANEL_TRACE
Alias:	PD (Panel Draw)
Space:	Layout Space

Purpose:

Function for drawing in un-coded wall frames between two selected points. There are a number of other options associated with this command as detailed below. These options are Model, Query, Undo, Setup and Rectangle.

Process:

- Input by points method:
- The input works on a three-point selection process.
- Type PD then press Enter (press Enter again to go to the setup options if required).
- Select the start point of the wall.
- Select the end point of the wall.
- Select which side of the line between these two points that you wish to place the wall.
- If a third point is not selected, then the wall will be centred through the first two points selected.

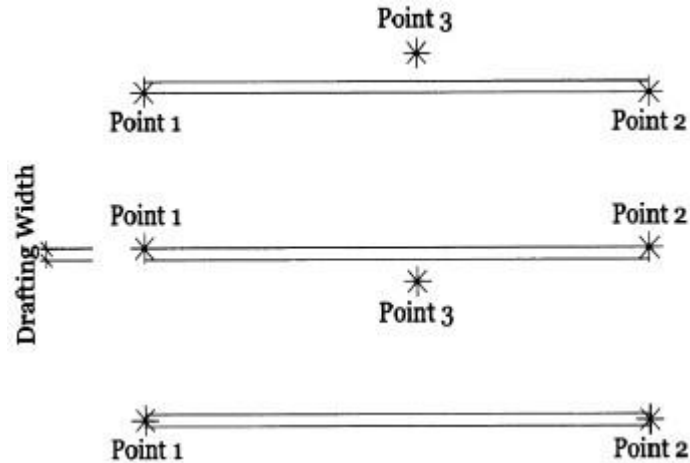

- Input by Rectangle method: This method is useful when tracing walls over an imported dwg or dxf plan (see LX and LS under Layer Commands).
- Type PD then press Enter.
- Type R for rectangle input method.
- Select the first point by clicking on one internal corner of a room then the second point by clicking on the opposite corner of the room. The walls will automatically be placed on the outside of this rectangle. Walls in subsequent rooms will automatically merge with existing walls.
- If walls need to be placed on the inside of the rectangle, hold the ALT key down when selecting the first corner point.

Additional Information:

Model: Type M to change to the various available wall models sequentially.

Query: Type Q to display the various models available.

Undo: Type U at any stage during the wall input to delete the last panel.

Setup: Type S to open the PSET settings.

5.9 PFB - Opening to Fit Brick

Commands:

Global name: _ PANEL_ BRICK

Local name: PANEL_ BRICK

Alias: PFB

Space: Layout Space

Purpose:

Moves openings to suit brick module sizes.

Process:

- Type PFB then press Enter.
- Select the opening to move.

5.10 PIB - Insert Brace

Commands:

Global name:	_ PANEL_ BRACE
Local name:	PANEL_ BRACE
Alias:	PIB
Space:	Layout Space

Purpose:

Allows the operator to insert bracing into the wall panels at layout stage. This command works with several different types of bracing. The available types are K-Brace, Bridging Brace, Double Strap brace, Single Strap brace, Engineered Wood and Wallboard Panel.

Process:

- Type PIB then press Enter.
- Press Enter again to go to the Brace Information section of the PSET dialogue box.
- After selecting the required brace type and making any other changes required, click on Save.
- Click on the panel locations where you wish to input any braces.
- Brace Types:
 - Bridging Brace

This provides an angle member between 2 studs and below the bottom nog of a wall frame. This bracing type is more commonly used in the American market, but could also be used for frame squaring purposes.

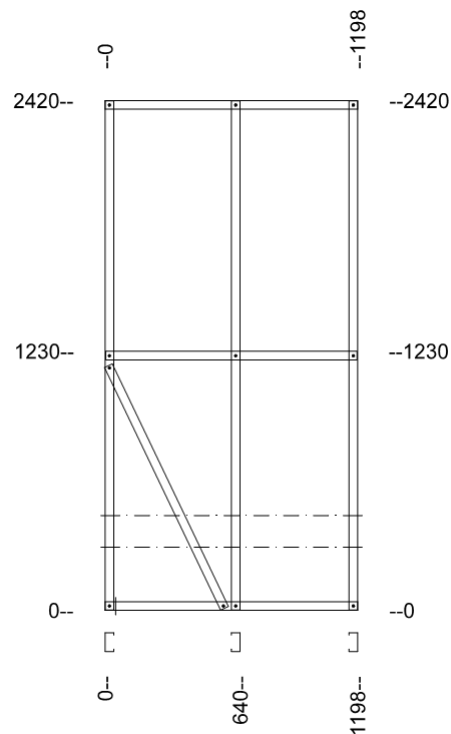

Additional Information:

K-Braces at the end of panels are orientated to allow for easier panel-to-panel fixing access at the top of the frame.

Type U at any stage during input to remove the last brace.

Reverse Brace Direction:

K-Braces and Bridging Braces show an arrow at one end on the plan view. This indicates the start end of the brace member at the bottom plate of the wall. Strap braces and sheet braces show an arrow at both ends. You are able to reverse the direction of K-Braces and Bridging Braces in both the plan layout view and the detail (elevation) view as per the instructions below:

- If you list (LI) a k-brace (or bridging brace) on the layout plan, there is now a 'Reverse Brace' option in the Brace Editor. The Reverse Frame/Reverse Member (RF/MR) command also works on the layout plan.
- If the elevation has already been built, you will need to run PUA for the brace direction to update in the detail sheet.
- If you list (LI) a k-brace (or bridging brace) on the detail sheet, there is now a 'Reverse Brace' option in the Panel Member Editor. The Reverse Frame/Reverse Member (RF/MR) command does not reverse the brace in the detail sheet. It will only flip the selected member orientation.
- Reversing the brace direction in the detail sheet will also reverse the brace in the layout plan.

K-Braces, Bridging Braces and Strap Braces can be input directly onto a wall panel in the detail sheet using the Insert Brace (**PIB**) command.

When running the command, the user is asked to select the start and finish studs. You must have the End Snap turned on and selection must be one end of the stud.

Note: Inputting K-Braces in the detail sheet will not automatically reverse the direction of the right-hand stud.

5.11 PLB - Lap Beam

Commands:

Global name:	_ PANEL_ LAP
Local name:	PANEL_ LAP
Alias:	PLB
Space:	Layout Space

Purpose:

To lap a beam into a wall panel thus creating a beam pocket within the wall.

Process:

- Insert a beam to meet the wall (not extending into or crossing the wall).
- Type PLB then press Enter.
- Enter a distance to lap the beam.
- Click on the end of the beam to lap. The length of the beam in plan view does not change, however the detailed length and reported length will be adjusted by these amounts.
- A "+" symbol will be placed on the side of the label that is extended.
- If you click on that beam end again, the lap will be removed and the "+" symbol will also be removed from the label.

Additional Information:

For beams that are perpendicular to a wall and extend over the wall, the pocket will automatically be inserted.

A pocket will not automatically be inserted into walls where the beam is in line and passing over the wall.

5.12 PN - Panel Notch

Commands:

Global name:	_ PANEL_ NOTCH
Local name:	PANEL_ NOTCH
Alias:	PN
Space:	Layout Space

Purpose:

Places a notch at the start or end of a wall frame along the bottom of the frame at a user specified height and width. Generally this notch would be used to facilitate and access the hold down flange of a structural steel post placed between wall frames.

Process:

- Type PN then right click or press Enter.
- Edit the height and width as required. The height refers to the distance from the bottom of the frame to the top of the notch. The width refers to the width of the notch from the end of the frame selected. Alternatively, select 'S' to go to the PSET settings to set a default size.

- Select close to the end of the wall in the layout that requires the notch.
- Selecting the same location again will remove the notch.

Additional Information:

After a notch is inserted, an asterisk is placed at the start or end of the wall label to indicate which end of the wall that the notch was placed.

When you list a notched frame, the Notching Information will show the show of the notches at the start end and finish end of the frame.

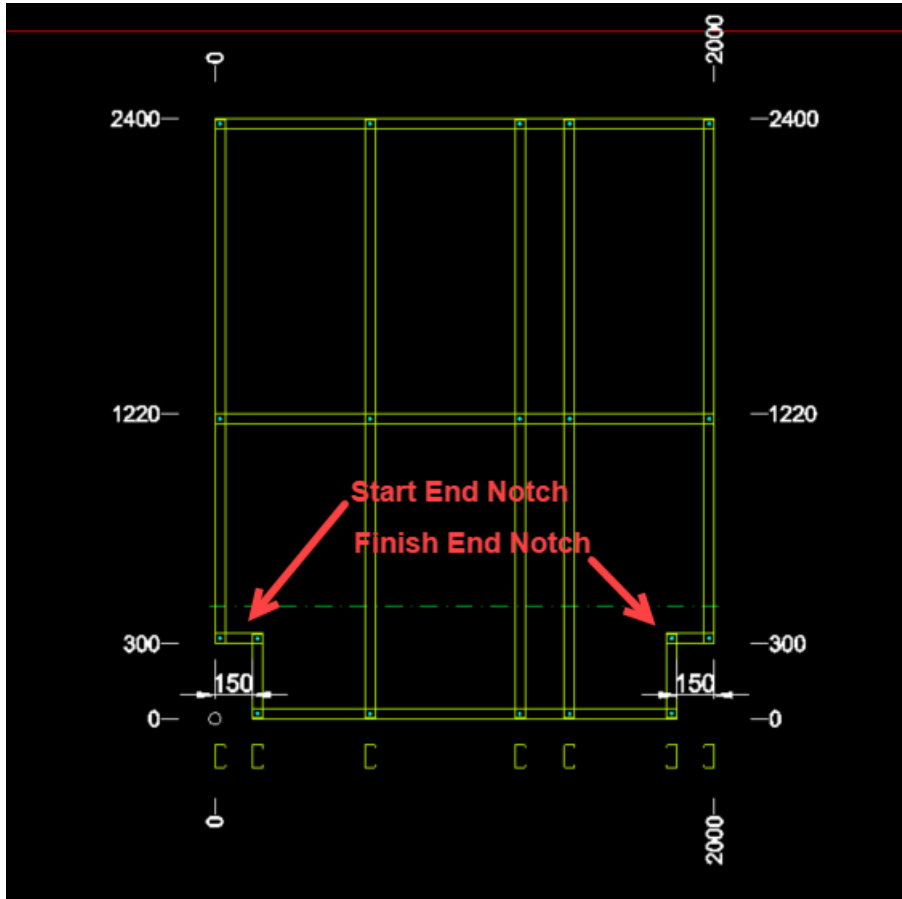

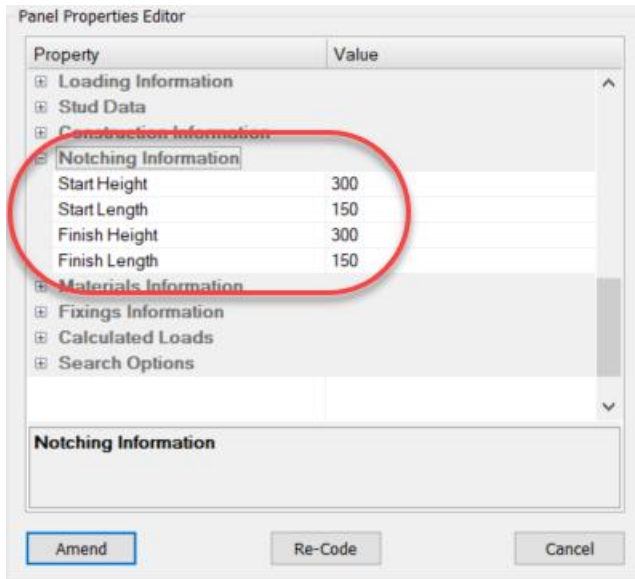

5.13 PPD - Panel Builder

Commands:

Global name:	<code>_ PANEL_ BUILDER</code>
Local name:	<code>PANEL_ BUILDER</code>
Alias:	<code>PPD</code>
Space:	Layout and Detailing Space

Purpose:

Exports wall panels, ceiling panels and beams to the 'Panel Builder'.

Process:

- From the wall framing layout, type PPD then press Enter. This will update all the studs and engineering for the walls then export them to the 'Panel Builder' dialogue box.
- From here the user can check each wall/beam individually in the 'Fabrication' window (or click on the Check button to do an automatic check). Other options available here are to be able to check the quantities for each wall/beam in the 'Bill of Materials' window, print or locate.
- Next, select the required walls/beams and click on To Cad to export to detailing space.

Additional Information:

To export frames one level at a time using the filter option:

Ensure that the border for the required layout is in focus.

Activate the PPD command.

Within the Panel Builder, select the 'Filters Are Off' option.

Change the 'Current View Only' option to 'True' and click on Change.

All other frames that are not within the initial screen view will be filtered out.

5.14 PPD - Panel Builder (Silent)

Commands:

Global name:	_PANEL_BUILDER
Local name:	-PANEL_BUILDER
Alias:	-PPD
Space:	Layout and Detailing Space

Purpose:

Allows the user to build panels from the layout while by-passing the Panel Builder dialogue box.

Process:

- From the wall layout type -PPD then press Enter.
- A new detailing space will be created within the job labelled 'Panel.1' into which the panels will be exported to.

5.15 PRA - Rake Panel

Commands:

Global name:	_PANEL_RAKE
Local name:	PANEL_RAKE
Alias:	PRA
Space:	Layout Space

Purpose:

To slope the top plate of a wall panel.

Process:

- Type PRA then press Enter.
- Select the walls to rake.
- Select two points to define the raking plane.
- Select the direction of the raking plane.
- Enter the required raking angle.

Additional Information:

Walls running parallel to the rake will have their height changed to suit the rake plane.

5.16 PRP – Panel Reaction Plan

Commands:

Global name:	_PANEL_REACTION
Local name:	PANEL_REACTION

Alias: PRP
 Space: Layout Space

Purpose:

This is basically a gravity reaction plan which shows the average uniform load from supported trusses, joists and wall panels. It also shows any point load reactions for jamb studs, both within a wall and from walls above, and from girder trusses and floor joist beam bearers.

Process:

- Ensure the wall layout plan is centred on the workspace.
- Type PRP then Enter.
- Layout will zoom to extents to show all borders.
- Click anywhere within the border that you wish to display the panel reaction plan.
- Enter or Esc to finish.

5.17 PSA - Stud Array Input

Commands:

Global name: `_PANEL_ARRAY`
 Local name: `PANEL_ARRAY`
 Alias: PSA
 Space: Layout Space

Purpose:

The stud array routine is used to place studs at specific locations overriding the automatic stud placement routines. This is very useful when studs need to be located at specific locations for the fixing of claddings.

This command also facilitates the insertion of single studs.

Process:

- For this command to work correctly the wall panel must already be coded.
- Type PSA then press Enter. The Stud Array Options Information in the PSET dialogue box will open.
- Make any changes and click on Save or click on Cancel if no changes are required. See 'Options' below for further detail.
- Once these settings have been saved, the command will default to these settings every time the command is used in this session.
- If settings need to be changed any time after the initial use, press Enter again to open the Stud Array Options Information in the PSET dialogue box.
- Make the necessary adjustments and Save.

Options – Stud Array Options Information:

<ul style="list-style-type: none"> ▪ Material Type 	Select material from the dropdown box if a specific material is required otherwise, leaving set to 'Auto' will use whatever
---	---

	material that has been set by the data file for the default system.
▪ Starting Position	This is the location of the first stud that will be inserted. This option is only available when using the 'By Points' insert option.
▪ Stud Spacing	This is the stud to stud spacing, i.e. the distance from the centre of one stud to the centre of the next stud.
▪ Stud Type	This is the stud arrangement of the studs that will be used. Boxed studs will only be shown if it is enabled in the data file. If using boxed studs, please ensure that the material is boxable, as the software will not check for this.
▪ Stud insert Type	Allows the user to select either 'Single Insert', 'By Points' or 'By Entities' methods. With the 'Single Insert', the user selects a single point anywhere along a wall frame, the cursor snap mode remains set at end point or intersection. The stud is inserted in the wall with the insertion point being dictated by the 'Stud Setout' option. With the 'By Entities' method, the user is prompted to select a wall entity, then for a starting point. Set out is calculated from this point. With the 'By Points' method, the studs are set out from the first point selected through to the second point selected. This selection can be applied along multiple walls.
▪	

The 'Material Type' combo box shows the type of stud to be used. To change stud type, select a stud as required from the drop-down list. Only studs available within your system are shown within this list. If the user selects 'Auto' then whatever type of common stud that would normally be used in that wall would be used.

The 'Starting Position' field is the location or position of the first stud. This is the distance from the starting point to the face or web of the stud. If the 'By Entity' or 'Single Insert' options were selected in the 'Insert Type' field then this field would be disabled.

The 'Stud Spacing' field is the spacing of all the other studs after the first stud. This distance is measured from face to face of the studs. If the 'Single Insert' options were selected in the 'Insert Type' field then this field would be disabled.

The 'Stud Type' combo box shows the available methods of insertion that will be used. The options available are 'Single Stud', 'Back to Back Studs' and 'Boxed Studs'.

The 'Insert Type' option allows the user to select either 'Single Insert', 'By Points' or 'By Entities' methods. With the 'Single Insert', the user selects a single point anywhere along a wall frame, the cursor snap mode remains set at end point or intersection. The stud is inserted in the wall with the insertion point being the middle of the flange of the stud unless a 'Back to Back' option was selected. In this case the insert point is the middle of the 'Back to Back' studs. With the 'By Entities' method, the user is prompted for a reference point and the set out is calculated from this point. For the selection of the set-out point, the cursor snap mode has been set to select end points or intersection and may be overridden using the standard Cad object snaps. With the 'By Points' method, the studs are set out from the first point selected through to the second point selected.

These dialogue settings are stored in your systems register and within 'Layer Zero' of the current drawing for future reference. When studs are inserted, the software will not insert studs at the ends of each wall panel or within a stud's thickness of the starting and ending point of a window. The tolerance for this is 1.25 times the stud width.

5.18 PSC - Stud Array Copy

Commands:

Global name:	<code>_ARRAY_COPY</code>
Local name:	<code>ARRAY_COPY</code>
Alias:	<code>PSC</code>
Space:	Layout Space

Purpose:

Copies the arrayed studs that were input using the PSA command, from one layout to another.

Process:

- Ensure that the border containing the stud array to be copied and the border that the stud array is to be copied to both have reference markers.
- The border that contains the stud array to be copied must be in focus.
- Type PSC then press Enter. The drawing will zoom out to show all the available borders.
- Select the border to copy the stud array to. Remember - this border must have a reference marker allocated to it.

5.19 PSN - Special Noggin Input

Commands:

Global name:	<code>_SPECIAL_NOGGIN</code>
Local name:	<code>SPECIAL_NOGGIN</code>
Alias:	<code>PSN</code> or <code>PSX</code>
Space:	Layout Space

Purpose:

To set up and place any special nog inputs that are used regularly.

Process:

- Type PSN then press Enter.

- Select an item from the description list.
- Select a point on a wall to locate the item.

Additional Information:

To add more special noggin options, go to the dialogue box, hold down the 'Alt' key and click on 'Description*'. This will change the options to enable a new special nog to be added or to amend an existing entry.

5.20 PST – Panel Stacks

Commands:

Global name: _PANEL_STACK

Local name: PANEL_STACK

Alias: PST

Space: Layout Space

Purpose:

To create a panel stacking order diagram. The order of the panels in the consecutive stacks will determine the order in which the panels will be sent out in the XML file during the CNC process starting with the frames from bottom to top of each stack.

Process:

- Type PST then press Enter.
- Enter again to go to the Panel Stacking Options.

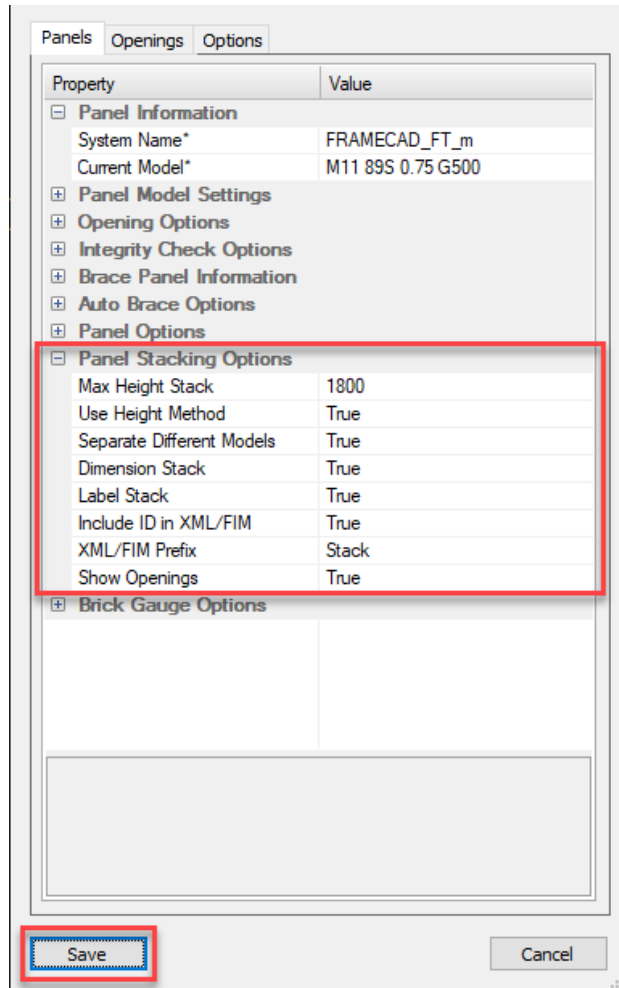

- Press 'Save' to save any changes and return to the next step, which is to select entities for stacking.
- Drag a fence over the panels within the layout to be included in the stacks.
- Select a location on a plan to display the stacks.
- By default, the panel stack order is based on panel length starting from longest on the bottom of the stack.
- Panels can be moved around within a stack using standard CAD operations.
- When moving panels within a stack or when moving panels from one stack to another, the recommended procedure is to run the MOVE command first, and then select and move the panels.
- If your preference is to use the context menu, i.e. select the panel first, then right click to select the Move command from the context menu, then you must run the LA command and select the amended stacks individually to update them prior to running the CNC command in the panel tab.
- There is a limitation of six panels that can be moved between stacks.
- If the stack information does not update correctly after any editing, i.e. dimensions or weights, then run the LA command and drag a fence over the stack to update.
- Stack label names can be changed by running the LA command and selecting the stack.

Additional Information:

PSET - Panel Stacking Options	Description
-------------------------------	-------------

Max Height Stack	Determines the maximum stack height before a new stack is created.
Use Height Method	Allows the user to create stacks based on maximum height or total stack quantities.
Separate Different Models	Separates the different wall models into different stacks.
Label Stack	Determines whether the stacks require labelling or not.
Include ID in XML/FIM	Includes the stack ID in the panel label when exported.
XML/FIM Prefix	Sets the required ID prefix.
Show Openings	Displays a representation of any openings on the end of each panel.

5.21 PUA - Update Panels

Commands:

Global name:	_PANEL_UPDATE
Local name:	PANEL_UPDATE
Alias:	PUA
Space:	Layout Space

Purpose:

Engines and updates wall panels.

Process:

- Type PUA then press Enter.

Additional Information:

All studs (except for PSA or locked studs) will be regenerated based on engineering requirements.

To rebuild studs without any re-engineering, use the **PBS** command.

This command will also re-engineer all the wall panels in the detail sheet elevations when run in the wall panel Detail Space.

5.22 SB - Show Brick

Commands:

Global name:	_SHOW_BRICK
Local name:	SHOW_BRICK
Alias:	SB
Space:	Layout Space

Purpose:

This is a checking command which shows indicative brick set out along a specified wall. Bricks are shown as half brick modules.

Process:

- Ensure correct brick size dimensions and brick cavity dimensions are set correctly in the PSET settings under 'Brick Gauge Options'.
- Type SB then press Enter.
- Select the wall to check then enter or right click.
- Select the end of the wall from where the brick veneer is to set out.
- If the brick veneer is set out from an internal corner, type 'I' then enter, then select the internal corner location.
- Enter again to remove brick or type SB and enter.

Additional Information:

5.23 SH - Show Heights

Commands:

Global name:	_SHOW_HEIGHTS
Local name:	SHOW_HEIGHTS
Alias:	SH
Space:	Layout Space

Purpose:

Shows walls in different fill colours according to height for checking purposes only.

Process:

- Ensure wall framing plan is in focus.
- Type SH then press Enter.

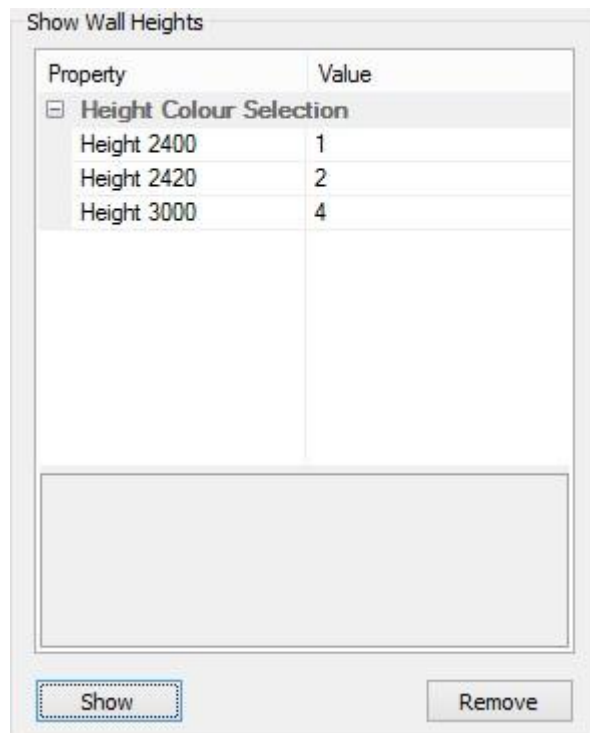

- Click on 'Show' to activate colours.

- Hold mouse button while selecting top bar of dialogue box and drag to one side to uncover the plan or
- Click on 'Remove' to uncover the plan.
- Click on 'Remove' to remove colours and revert plan back to normal.

Additional Information:

Colours can be changed by changing the numbers or clicking on the button to the right of the numbers and selecting the required colour.

6 Truss Commands

6.1 BG - Box Gutter

Commands:

Global name:	_BOX_GUTTER
Local name:	BOX_GUTTER
Alias:	BG
Space:	Detailing Space

Purpose:

This option allows the user to input a notch in the end of a truss which would generally be used for a boxed gutter situation.

Process:

- In the truss detailing space, ensure the truss to be modified is in focus.
- Type BG then right click or press Enter.
- In the command bar, enter in the size required.
- Click on the bottom chord and closest to the end of the truss where the boxed gutter is to be applied.

Additional Information:

Note: The use of this command will require some manual modification in most cases. Member reinforcing may be required for engineering to work.

6.2 CM - Code Member

Commands:

Global name:	_LAYOUT_MANAGER
Local name:	LAYOUT_MANAGER
Alias:	CM or ADD
Space:	Detailing Space

Purpose:

Allows the user to code a line as a member (i.e. web, chord or rail).

Process:

- Draw a line or lines at the required location and length.
- Type CM then press Enter. This launches a 'Code to a Member' dialogue box.
- Select the member type from the Material Usage list. Select the correct Material Name.

6.3 CRL - Create Roof Lines

Commands:

Global name: _ROOF_LINES
 Local name: ROOF_LINES
 Alias: CRL
 Space: Layout Space

Purpose:

Creates Hip, Valley and Ridge lines by selecting Roof Blocks on the Eave Lines (Blue lines only)

Process:

- Type CRL then press Enter
- Select first and second points for roof lines; points 1 and 2 determine the common truss orientation (roof width)
- Select third point for roof lines; point 3 determines the extent of the trusses (roof length)
- Select the roof type for the first roof end as indicated by the asterisk:
- o Dutch (D), Hip (H), Gable (G), Valley (V), GAmbrel (GA), Boomerang (B), Radial (R), Unequal Radial (U), DOrmer (DO) and DRopped Valley (DR); enter the upper case letter(s) □
 Select the roof type for the second roof end as indicated by the asterisk.
- The following images show the three selection points and examples of several roof type selections:

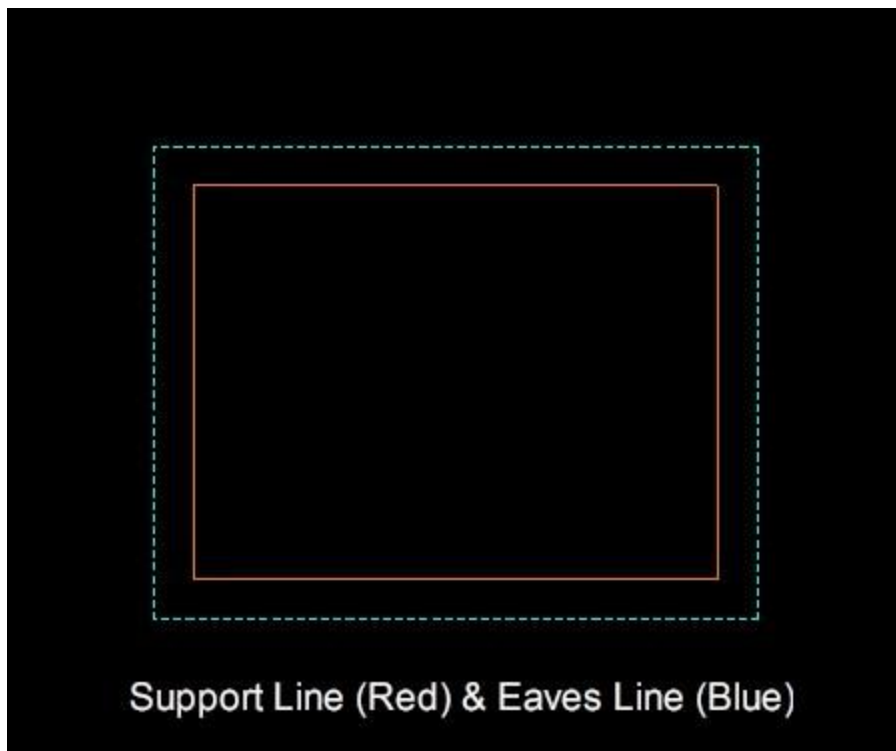

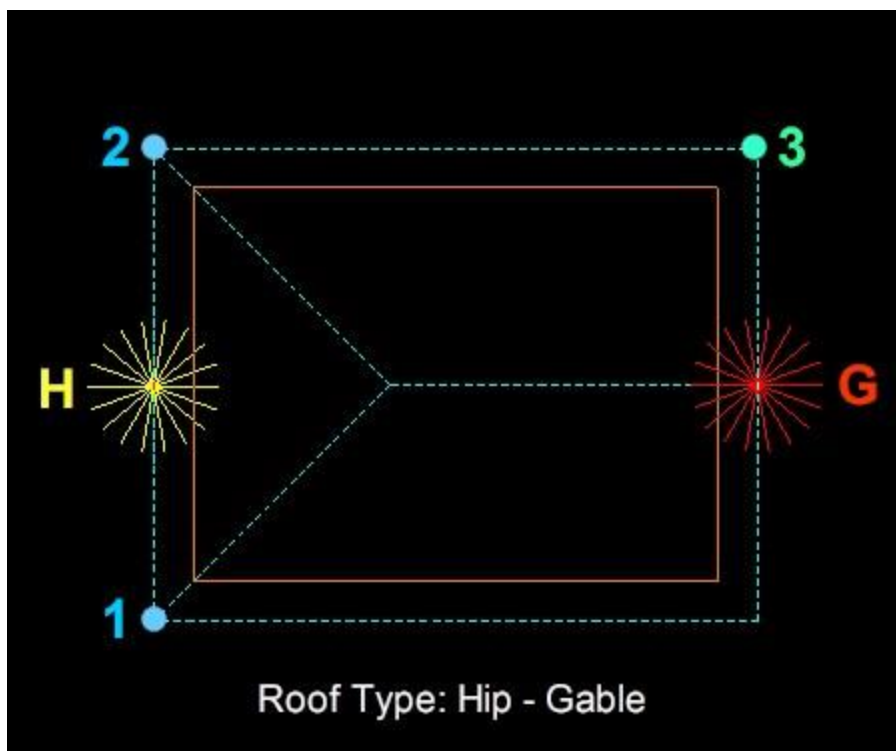
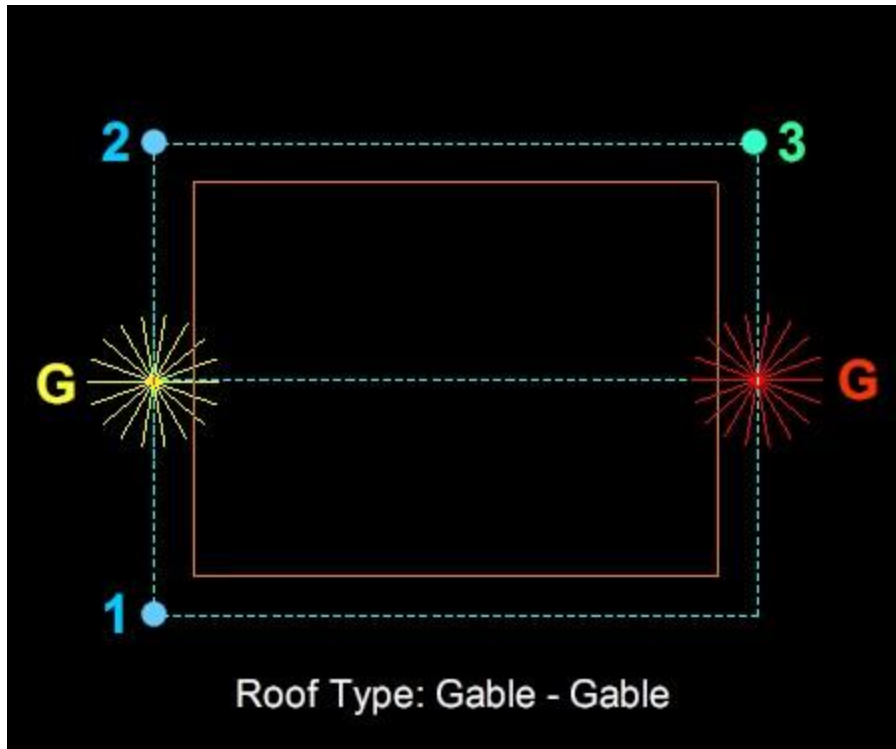

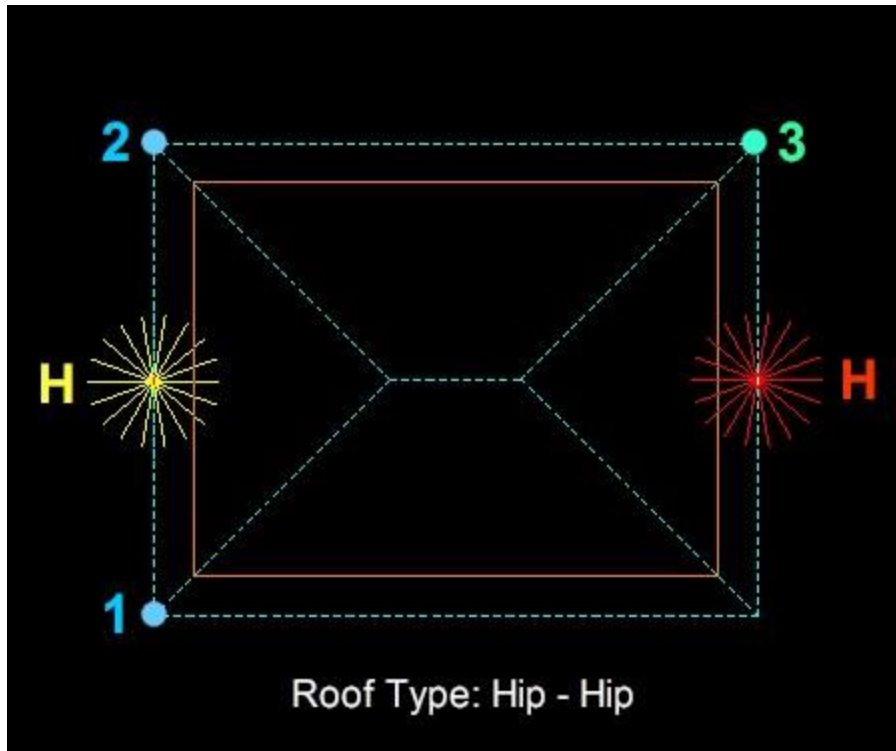

Additional Information:

By default, the Roof Type is Gable which is the simplest type; if no letter is entered the roof type is assumed Gable

6.4 RCR - Copy Roof

Commands:

Global name:	_ROOF_COPY
Local name:	ROOF_COPY
Alias:	RCR
Space:	Layout Space

Purpose:

Copies the roof lines and support lines from one plan to another.

Process:

- Ensure that the border of the roof outline that you wish to copy is in focus on the screen.
- Type RCR then press Enter. The plan will zoom to extents.
- Select the border that you require the roof and support lines to be copied to.
- Press Enter or Escape to exit the command. The plan will zoom back into the original roof border.

6.5 RL - Code Roof Line

Commands:

Global name:	_TRUSS_RLINE
Local name:	TRUSS_RLINE
Alias:	RL
Space:	Layout Space

Purpose:

Codes a line as a roof line. The roof lines are a vital part of truss layouts as they are used to detect eave overhangs.

Process:

- Type RL then press Enter.
- Select the lines to be coded then press Enter.

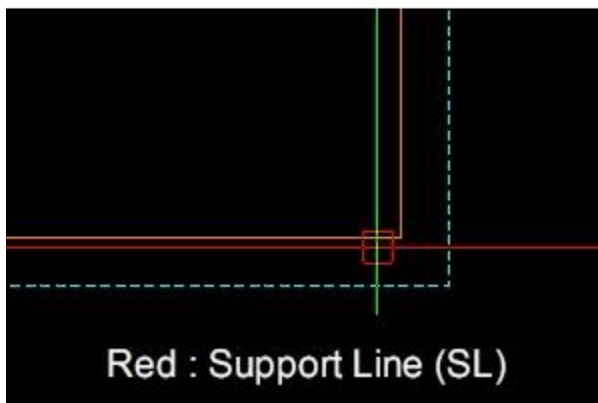
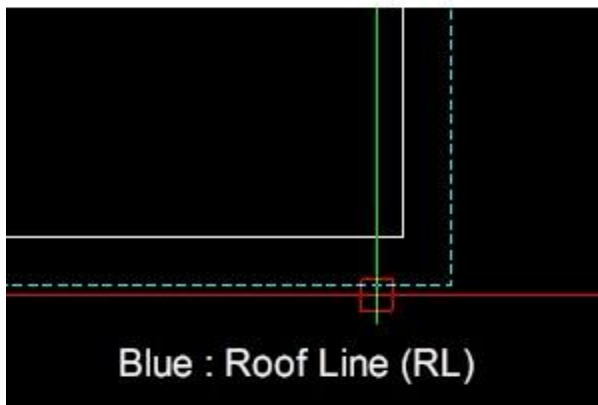
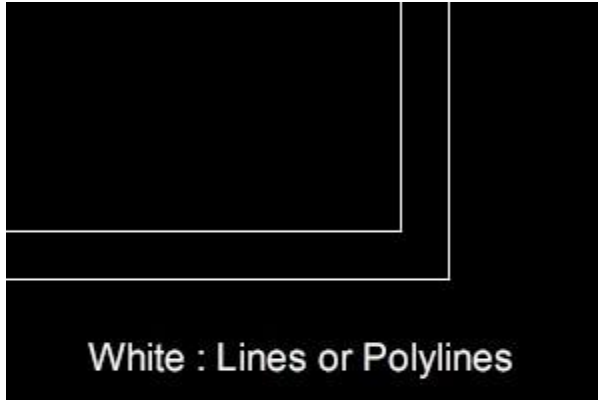

Additional Information:

The line is changed to a different linetype and colour, plus it breaks the lines at all roof line intersection points and embeds a mark to allow the software to recognise it as a roof line. If you select a polyline, it will be converted to ordinary lines.

6.6 RS - Roof Shape Input

Commands:

Global name:	<code>_ROOF_SHAPE</code>
Local name:	<code>ROOF_SHAPE</code>

Alias: RS
 Space: Layout Space

Purpose:

Allows the user to input pre-defined roof shapes and generate trusses for that roof. Generally this command is used as a quick roof input for demonstration purposes.

Process:

- Ensure that the border you wish to use is in focus and centralised on the screen. The best way to ensure this is correct is to type V (Go To View) then Enter, then the border letter then Enter.
- Type RS then press Enter.
- Select the required shape.
- Enter the roof pitches, eaves width and predominant roof type.
- Tick on or off to include roof trusses.
- Roof settings can also be altered here by clicking on the 'Settings' button.
- Click on 'Create' to input the roof.

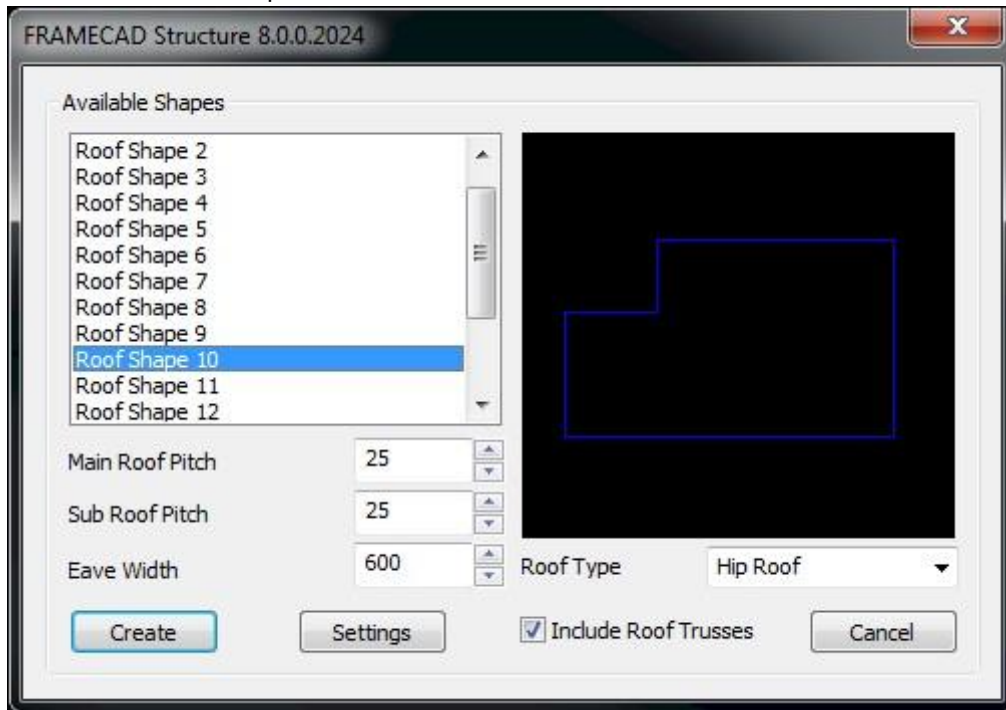

- As the perimeter is being input, the user can edit any of the lengths as required; a marker indicates the current side for length entry.

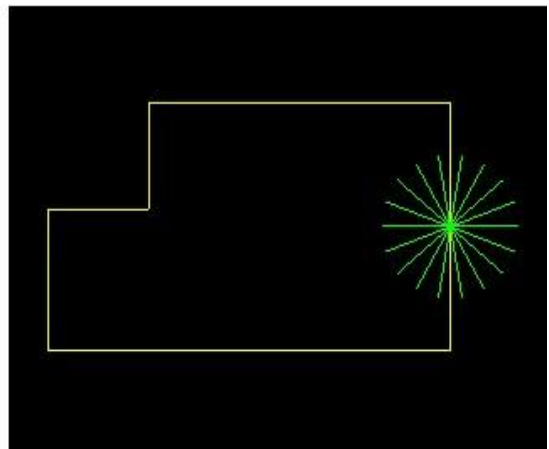
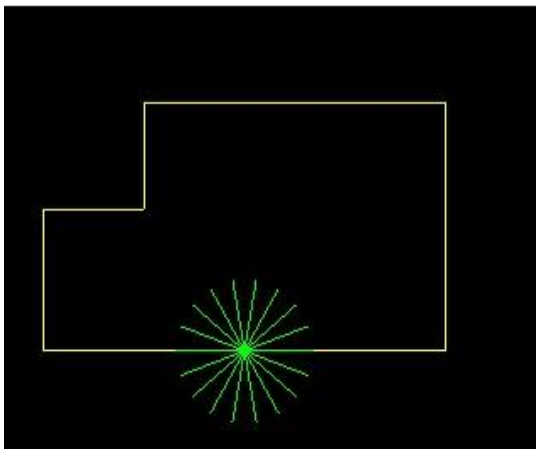
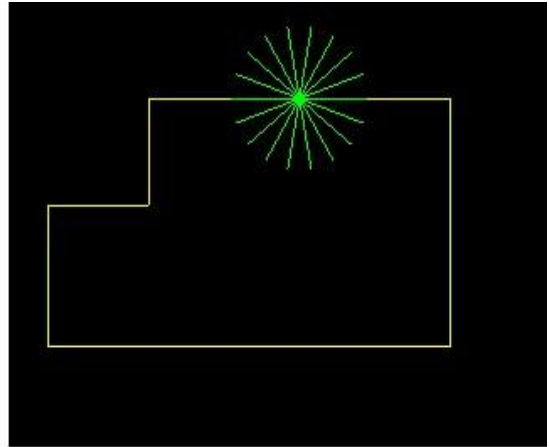
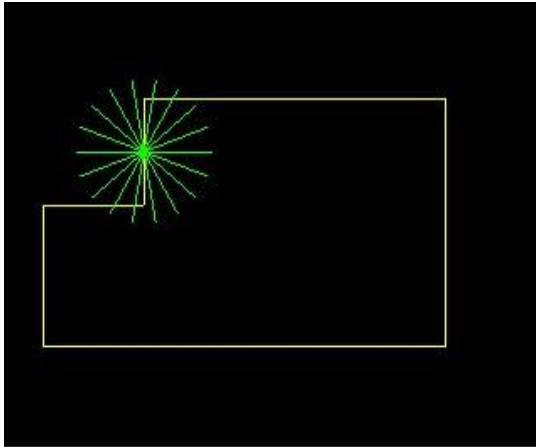

- After length of all required sides are entered, the roof trusses are created if 'Include Roof Trusses' was ticked.

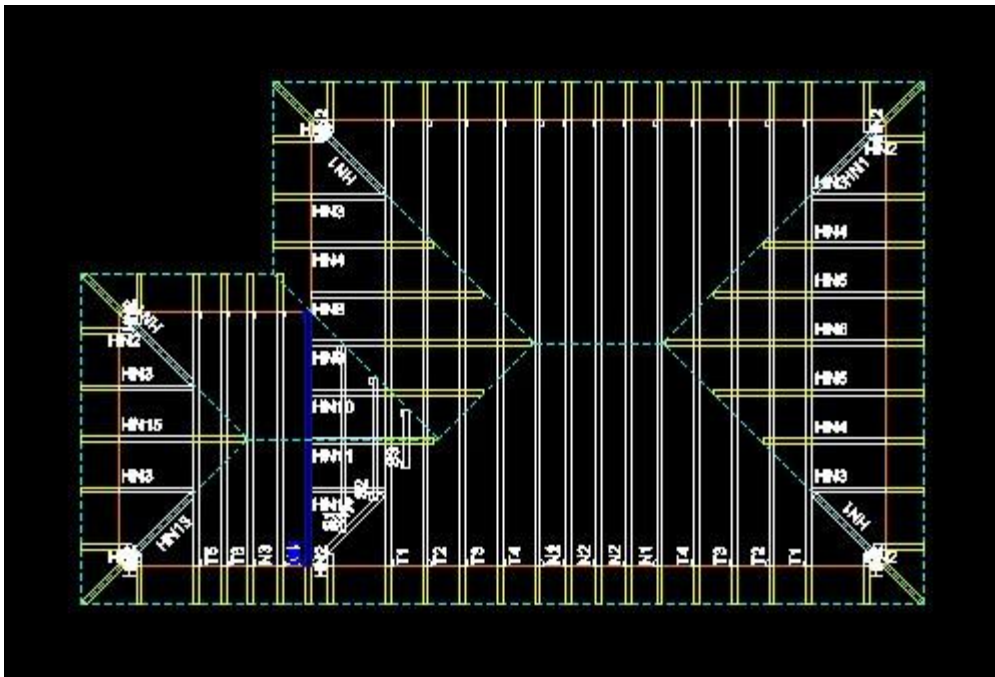

6.7 TC – Truss Connections

Commands:

Global name:	_TRUSSCONNECTIONS
Local name:	TRUSSCONNECTIONS
Alias:	TC
Space:	Layout Space

Purpose:

Allows the user to create a truss connection layout plan. This plan displays the brackets required for truss to top plate connections and truss to truss connections.

Available Options:

Options for this command are located in 'TSET' => 'Options' => 'Connections Option':

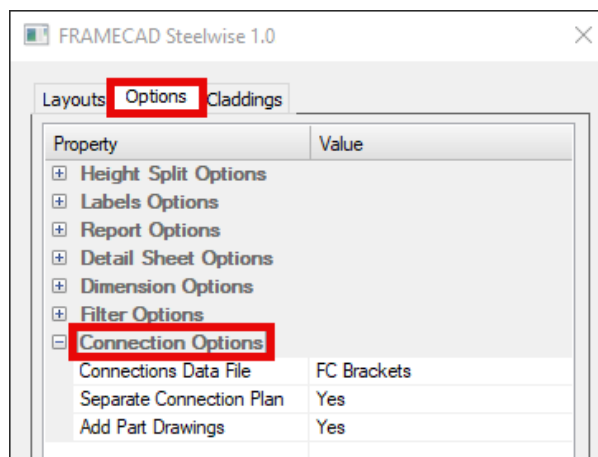

Connection Data File

Here you select the data file you want to use that contains the connection data. This is a point in time setting, meaning that if you create a bracket plan after changing this setting then previous bracket plans will remain unchanged.

Separate Connection Plan

If value is set to 'Yes' the bracket plan will be placed on a separate border prompting the user to select a point within the border. Anything within the selected borders will be deleted. Gridlines and reference points are also copied.

If value is set to 'No' the bracket plan will be placed on top of the roof truss layout, if the bracket plan already exists in the truss layout, it will be deleted and redone not affecting the truss layout. Summaries on page will be added in addition to the layout summaries.

Add Part Drawing

If value is set to 'Yes', when you create a connection plan you will be prompted for the locations of blocks of all the brackets used when the blocks are available. Please note, this is the blocks of brackets and NOT connection details.

If value is set to 'No', no bracket blocks will be inserted. If the user did not opt to insert the bracket drawings at the command time, he/she can do so later with the 'ID' command.

How to Use the command:

Make sure you have a truss layout on the screen before running the command. The command should be run after the trusses have been laid out and built on a detail sheet and after the walls have been laid out and built on a detail sheet. Currently, floor framing has no effect on it.

If the user did not opt to insert the bracket drawings at the command time, he can do so later with the 'ID' command.

Listing:

There are two methods of listing. You can list the individual symbols on the bracket plan, or you can list the symbol in the top left summary box. Listing individual items will change those individual items only and should update the summary boxes when completed.

Listing a symbol in the top left list box will change all symbols (with the same symbol) on the current plan. When complete, it will update the current plan and cutting lists.

Hyperlinks:

Hyperlinks are set to various items on the bracket plans. The text at the top middle of the border has a hyperlink attached to it. This link is set in the data file and is currently set to 'www.framecad.com'. Each bracket block can also have a hyperlink attached to it. Once again that is set in the data file. Currently no blocks have a hyperlink set. To use the hyperlink option, hover over the item, hold your finger on the 'CTRL' key and click on the item. It should then take you directly to the web location. Refer to IntelliCAD help for more information.

Colour Coding:

Symbols are colour coded and are not customizable by the user.

Colour	Purpose
Green (3)	Used prescriptive method
Red (1)	Reactions or data was not found
Yellow (2)	Calculated OK
Dark Green (106)	Amended by user

Reports:

'REP' and 'SUM' commands should pick up the brackets and the relevant fixings. These items are no longer included in the 'TOA' command - existing calculation methods were removed from the 'TOA' command. The 'OR' command should update the on-page summaries.

6.8 TD - Truss Layout Input

Commands:

Global name: _TRUSS_LAYOUT
 Local name: TRUSS_LAYOUT
 Alias: TD (Truss Draw)
 Space: Layout Space

Purpose:

Tool to create roof truss layouts of various roof end types and truss types, e.g. half trusses, parallel chord trusses, etc.

Also used for inputting top chord and bottom chord strap bracing.

Process:

Before any trusses can be input, a polyline must be drawn around the building to represent the external loadbearing support lines. This polyline will represent the heel location (support line) of the trusses and be coded as a Support Line (SL). Roof lines representing the eaves overhang may also be added if required. These lines will have to be coded as Roof Lines (RF).

The TD command can only input trusses onto theoretical rectangular blocks defining the width of a roof block and the length of a roof block, therefore, the building will have to be broken up into theoretical rectangular blocks connected to each other. Once this has been done the truss layout can then commence.

- Type TD then press Enter.
- Right click or press Enter to display the TSET dialogue box.
- Make any setting changes and Save.
- Select the two corners at one end of the rectangular roof block which determine the width of the block and then a point anywhere along the opposite end of the rectangle to establish the length of the roof block. Remember: the first two points determine the width of the block (or the main truss span) and the third point determines the length of the block.
- Next, select the roof type at the first end of the block. This can either be done by typing the shortcut for the roof type (indicated by the uppercase letters of the names displayed in the command bar) or type M for More. 'More' will display the full list of roof end types. Select the roof type option and click on 'OK' or double click on the required roof type if selecting from the More dialogue box.
- Repeat the process for the opposite end of the roof block. The trusses will be placed according to the TSET settings.

Please refer to the **Truss Layout Input** section of the **Procedures Overview** manual for more detailed information.

6.9 TOA - Truss Accessories Report

Commands:

Global name:	_TRUSS_ ACCESSORIES
Local name:	TRUSS_ ACCESSORIES
Alias:	TOA
Space:	Layout Space

Purpose:

Adds an on-page report for the truss accessories to the truss layout.

Process:

- Type TOA then press Enter.
- The accessory report is automatically added to the top right corner of the truss layout plan regardless of where the focus is on the plan.

6.10 TPL - Add Truss Point Load

Commands:

Global name:	_TRUSS_POINT
Local name:	TRUSS_POINT
Alias:	TPL
Space:	Layout and Detailing Space

Purpose:

Allows a point load to be added to a truss.

Process:

- Type TPL then press Enter. This will open the Point Load Editor dialogue box.
- Change the required values then click on 'Add'.
- Select the location for the point load on the truss. Right click for single insert.
- For multiple insert, drag the second point location to the last truss.

Additional Information:

Point loads can only be added to a truss chord member.

6.11 TRE - Rebuild Eaves

Commands:

Global name:	_REBUILD_EAVES
Local name:	REBUILD_EAVES
Alias:	TRE
Space:	Layout Space

Purpose:

Rebuilds any missing truss overhang extensions.

Process:

- Type TRE then press Enter.
- Select the trusses to rebuild the eaves then right click or press Enter.
- Or...
- Press Enter for a global selection then right click or press Enter.

6.12 TS – Solar Panel

Commands:

Global name:	_TRUSS_SOLAR
Local name:	TRUSS_SOLAR
Alias:	TS
Space:	Layout Space

Purpose:

Adds a solar panel to a roof which applies point loads to the trusses.

Process:

- Type TS then right click or press Enter.
- Press Enter again to go to the settings. Select 'Save' if any changes are made or 'Cancel' if no changes are made.
- Select the location to place the solar panel(s).
- Select the orientation of the panel. The label text should run perpendicular to the trusses.
Note: The orientation MUST be correct otherwise the loads will not be applied to the trusses.

Solar Panel Settings:

Panel Height	Vertical dimension
Panel Width	Horizontal dimension
Panel Quantity	Horizontal dimension will be multiplied by this value
Support Spacing	Spacing distance for supports running horizontally
Panel Weight	Weight in kN/m ²
Panel Weight	Weight in kg/m ²
Panel Text	Change to suit
Panel Colour	Change to suit

Additional Information:

Point Load markers are added to the top chord of the trusses at the support member locations in the truss elevations.

6.13 TTD - Truss Builder

Commands:

Global name:	_TRUSS_BUILDER
Local name:	TRUSS_BUILDER
Alias:	TTD
Space:	Layout and Detailing Space

Purpose:

Allows the user to build trusses from the layout or add or amend trusses in detailing space.

This command runs in several modes, each is listed below:

Builds trusses from the layout drawing and displays in a dialogue box. This occurs when the drawing is in layout space and there is a truss layout present.

Allows the user to build a truss and displays it in a dialogue box. When adding to CAD, it adds it to a new detailing space. This occurs when the drawing is in layout mode and there are no trusses present.

Shows the current truss in a dialogue box and allows the user to alter or update this truss with the tools available or shows complete engineering data. This occurs when the drawing is in detailing space and there is a truss current on the screen.

Allows the user to build a truss and displays it in a dialogue box. The user can then add it to the current trusses in the current detailing space. This occurs when the drawing is in detailing space regardless of whether trusses are present or not.

Allows the user to print various engineering reports for individual or multiple trusses at once.

Process:

Exporting Trusses from Layout (Layout Space):

- Type TTD then press Enter.
- The Truss Builder dialogue box will open listing all the trusses in the job. All the trusses have been engineered at this stage. Within this dialogue box you can check the material usage, engineering diagrams and results for each truss. You can also change any individual truss parameters in the Truss Editor dialogue box by double clicking on a truss in the Item list.
- Select the required trusses to export then click the 'To Cad' button.
- A new detailing space will be created within the job labelled 'Truss.1' and all the selected trusses will be drawn in.

Amending Trusses in Elevation View (Detailing Space):

- Ensure that the truss you wish to amend is in focus.
- Type TTD then press Enter. The Truss Builder dialogue box will open listing the truss in focus.
- Double click on the name of the truss in the left pane; this will open the Truss Editor dialogue box.
- Make any changes and click on the 'Amend' button then click on the 'Update' button in Truss Builder. The truss will be updated and engineered.

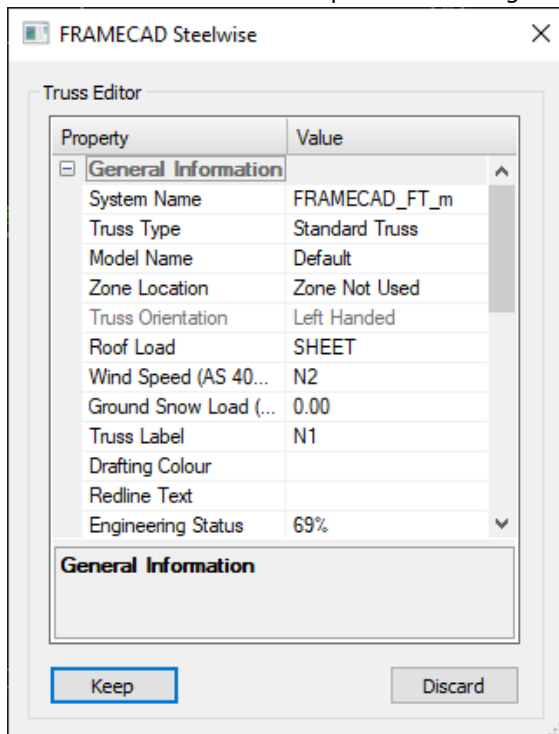

Viewing Bill of Materials:

In the Truss Builder view, select a truss in the left pane
 Click on the Bill of Materials (BOM) tab
 BOM for the selected truss is displayed in a table
 Select another truss in the left pane to display the BOM of that truss

Viewing Engineering Summary & Diagrams:

On the Truss Builder dialogue box select a truss in the left pane
 Click on the Engineering tab

Select an item from the dropdown list at the top-right on the Truss Builder dialogue box. Select a Load Case from adjacent dropdown list, if available, to generate diagrams corresponding to the selected load case.

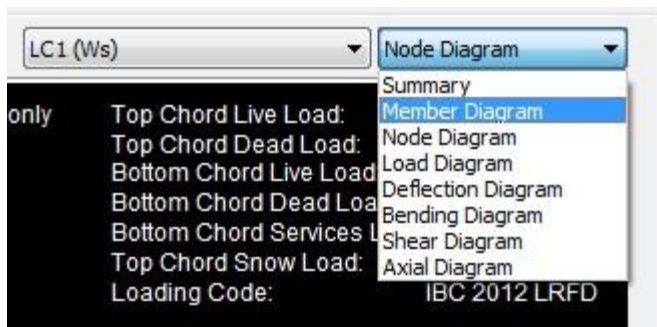

Following diagrams are available:

Summary: Shows engineering summary, including the maximum design index (stress or deflection) for all load cases

Member Diagram: Shows the analytical member numbers (IDs); long segments between two panel points are divided into two or more analytical (finite) members

Node Diagram: Shows the analytical node numbers (IDs); each analytical member has two end nodes - start and end nodes

Load Diagram: Shows load diagrams mainly as distributed loads for different load cases;

including a set of loadings with a moving point load o **Deflection Diagram:** Shows the maximum deflection envelope under selected load case o **Bending Diagram:** Shows the maximum bending moment envelope under selected load case o **Shear Diagram:** Shows the maximum shear envelope under selected load case o **Axial Diagram:** Shows the maximum axial force (compressive or tensile) envelope under selected load case

Viewing Detail and Engineering Results:

On the Truss Builder dialogue box select a truss in the left pane
 Click on the Results tab

Select an item from the dropdown list at the top-right on the Truss Builder dialogue box. Select a Load Case from adjacent dropdown list to generate result table corresponding to the selected load case.

LC16 (1.2G + 1.6P)		Node Inputs
Y Force	Support Type	Node Inputs
kN		Node Results
0.000	Free	Member Input
0.000	Pinned	Member Shape
0.000	Free	Member Properties
0.000	Free	Member Capacities
0.000	Free	Member Forces
0.000	Free	Code Status
		Yes
		Yes

Following result tables are available:

Node Inputs: Lists coordinates, applied node forces, support type, member release, etc. for each Node

Node Results: Lists displacements, reactions, joint load, joint capacity, etc. for each Node

Member Input: Lists IDs of end nodes, segment length, design length, restraint length, forces, member type (BC, TC or Web), etc. for each Member

Member Shape: Lists CFS section profile, profile dimensions, coil thickness, steel properties, etc. for each Member

Member Properties: Lists coil width, cross-section area, linear weight, and other physical and engineering properties for each Member

Member Capacities: Lists member and section capacities (shear, tensile, compressive, bending up, bending down) and sectional properties for each Member

Member Forces: Lists maximum axial force, shear force, bending moment and displacement at characteristic points along each Member

Code Status: Lists shear, tensile, compressive, bending and combined strength index, and deflection index in accordance to selected Design Code, for each Member

Printing Engineering Results:

Select the Engineering tab.

Select all the trusses in the left-hand pane (individual trusses can also be selected if required).

Click on Print to activate the Printing Options.

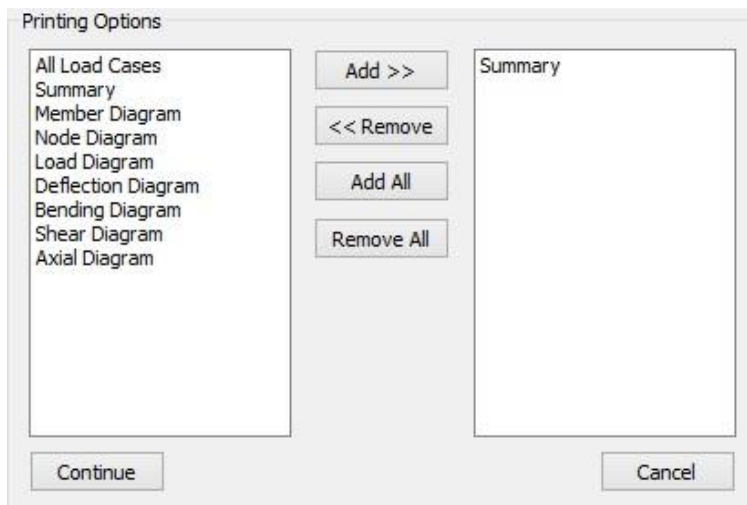

The 'Printing Options' dialog box contains two panes. The left-hand pane lists the following options: All Load Cases, Summary, Member Diagram, Node Diagram, Load Diagram, Deflection Diagram, Bending Diagram, Shear Diagram, and Axial Diagram. The right-hand pane is currently empty and labeled 'Summary'. Between the panes are four buttons: 'Add >>', '<< Remove', 'Add All', and 'Remove All'. At the bottom of the dialog are 'Continue' and 'Cancel' buttons.

Add the required options from the left-hand pane to the right-hand pane.

Click on Continue to print.

Additional Information:

Truss web extension past dimple

There is a data file option which allows individual truss types to have their webs extended to within a given distance of the edge of the chords. This is a data file setting – please create a ticket in MyFramecad to request any data file changes.

6.14 -TTD - Truss Builder (Silent)

Commands:

Global name:	__-TRUSS_BUILDER
Local name:	-TRUSS_ BUILDER
Alias:	-TTD
Space:	Layout and Detailing Space

Purpose:

Allows the user to build trusses from the layout while by-passing the Truss Builder dialogue box or re-engineers a given truss.

This command runs in two modes, each is listed below:

1. Builds all trusses from the layout drawing and sends through to detailing space. This occurs when the drawing is in layout space and there is a layout present. When in this mode all filters are ignored.
2. Updates engineering status of current truss. This occurs when the drawing is in detailing space and there is a truss current on the screen.

Process:

1. Exporting trusses from layout (layout space):
 - Type -TTD then press Enter.
 - A new detailing space will be created within the job labelled 'Truss.1' into which the trusses will be exported to and engineered.
2. Updating engineering status of current truss in elevation view (detailing space):
 - Ensure that the truss you wish to engineer is in focus.
 - Type -TTD then press Enter. The truss will be updated and engineered.

6.15 TUA - Update Truss Engineering

Commands:

Global name:	_PANEL_UPDATE
Local name:	PANEL_UPDATE
Alias:	TUA
Space:	Detail Space

Purpose:

Updates engineering for all trusses in the detail space.

Process:

- Go to the truss detail sheet tab
- Type TUA then press Enter.

Additional Information:

6.16 TUP - Truss Uplift Plan

Commands:

Global name:	_TRUSS_UPLIFT
Local name:	TRUSS_UPLIFT
Alias:	TUP
Space:	Layout Space

Purpose:

Inserts a truss uplift plan into a selected border.

Process:

- Ensure the truss layout plan is in focus.
- Type TUP then press Enter. Plan will zoom out to extents.
- Select the blank border where the truss uplift plan is to be placed. Plan will zoom back to the truss layout plan.

7 Floor Commands

7.1 FD - Draw Floor

Commands:

Global name:	_ ROUGH_IN
Local name:	ROUGH_IN
Alias:	FD
Space:	Layout Space

Purpose:

Creates an underfloor layout in one border and a floor framing layout in the next border. A flooring sheet layout will also be drawn in the next border if the 'Auto Floor Sheet Layout' option is set to 'True' in the Layout Options of the JSET.

Process:

- Ensure you have your floor outline(s) drawn in.
- Type FD then press Enter.
- Select the outline(s) and right click or press Enter.
- Select a set out point from which all the joists will be set from.
- Select the direction that the joists will run. The underfloor piers will be drawn in on the initial border, an identical layout will be reproduced on the next border with the floor joists detailed in, and if the Auto Floor Sheet Layout option is on, a floor sheet layout will appear in the following border.

7.2 FR – Floor Recess

Commands:

Global name:	_ FLOOR_SETDOWN
Local name:	FLOOR_ SETDOWN
Alias:	FR (Floor Recess)
Space:	Layout Space

Purpose:

Allows a top chord recess to be applied to designated area of floor joists.

To be implemented at the users discretion – see additional information below.

Process:

- On the floor joist layout plan, draw a polyline to represent the area to be recessed.
- Type FR
- Enter in the recess drop value.
- Click on the polyline.

Additional information:

Important Note: Recessed floor joist Engineering Status is set to 'Non-Structural'. They are not engineered in the Steelwise software, therefore it is the responsibility of the user to have these joists engineered externally.

7.3 FSD - Floor Sheet Input

Commands:

Global name:	_ FLOOR_SHEET
Local name:	FLOOR_SHEET
Alias:	FSD (Floor Sheet Draw)
Space:	Layout Space

Purpose:

To lay out floor sheathing over a floor joist layout.

This command works similar to the 'JD' command. All you need to do is select the boundaries of the floor you wish to add sheathing to. The boundaries could be either lines or polylines and should be a closed area. The boundaries could consist on any shape or collection of shapes and several separate boundaries could be included.

Process:

- Type FSD then press Enter.
- Press 'Enter' again to go the 'JSET' setup form.
- On completion of 'JSET', you will be returned to this routine. Select a boundary then right click or enter.
- Select a set out point from which all the sheathing is set from.
- Next you will be prompted for the direction of the joists. Drag the mouse and click anywhere along the first joist.
- The floor sheets will be laid out accordingly and an on-page report is generated with sheet, screw and glue quantities.

7.4 JD - Joist Layout Input

Commands:

Global name:	_ FLOOR_LAYOUT
Local name:	FLOOR_LAYOUT
Alias:	JD (Joist Draw)
Space:	Layout Space

Purpose:

Function for inputting floor joist members within a designated area.

To use this command, all you need to do is select the boundaries of the floor you wish to detail. The boundaries could be either lines or polylines and should be a closed area. The boundaries could consist of any shape or collection of shapes and several separate boundaries could be included or excluded.

Process:

- Ensure that you have the correct system, model and other settings correct in JSET.
- Ensure you have your floor outline(s) drawn in.
- Type JD then press Enter.
- Select the outline(s) and right click or press Enter.
- Select a set out point from which all the joists will be set from.
- Next you will be prompted for the direction of the joists. Drag the mouse in the joist direction required and click anywhere along the line adjacent to the setout point.
- The floor joists will be created accordingly and automatically labelled if that option is set to 'True'.

Additional information:

Refer to the Procedures Overview manual for more comprehensive floor input information.

7.5 JJD - Floor Joist Builder

Commands:

Global name:	_ FLOOR_BUILDER
Local name:	FLOOR_BUILDER
Alias:	JJD
Space:	Layout and Detailing Space

Purpose:

Allows the user to build floor joists from the layout or amend floor joists in the detailing space.

This command runs in several modes, each is listed below:

Builds joists from the layout drawing and displays in a dialogue box. This occurs when the drawing is in layout space and there is a joist layout present.

Shows the current truss in a dialogue box and allows the user to alter or update this truss with tools available. This occurs when the drawing is in detailing space and there is a joist current on the screen.

Process:

- Exporting joists from layout (layout space):
- Type JJD then press Enter.
- The Joist Builder dialogue box will open listing all the joists in the job. The materials usage can be checked for each joist from within this dialogue box. You can also change any individual joist parameters in the Joist Editor dialogue box by double clicking on a joist.
- Select the required joists to export then click the 'To Cad' button.
- A new detailing space will be created within the job labelled 'Floor.1' and the joists will be drawn in.

Amending joists in elevation view (detailing space):

- Ensure that the joist you wish to amend is in focus.
- Type JJD then press Enter. The Joist Builder dialogue box will open listing the joist in focus.
- Double click on the name of the joist in the left hand space. This will open the Joist Editor dialogue box.

- Make any changes and click on the 'Amend' button then click on the 'Update' button in Joist Builder. The joist will be updated.

7.6 JSV - Floor Section View

Commands:

Global name:	_ FLOOR_SECTION
Local name:	FLOOR_SECTION
Alias:	JSV
Space:	Layout Space

Purpose:

Creates a cross section through a floor layout.

Process:

- Type JSV then press Enter. If you are in detailing space, actioning this command will revert to layout space.
- Drag a horizontal or vertical line through a floor layout then click on a space to display it.

7.7 Under Floor Pier

Commands:

Global name:	_ ISOLATED_PIER
Local name:	ISOLATED_PIER
Alias:	
Space:	Layout Space

Purpose:

Process:

7.8 Under Floor Post

Commands:

Global name:	_ ISOLATED_POST
Local name:	ISOLATED_POST
Alias:	
Space:	Layout Space

Purpose:

Process:

8 Smart Panel Commands

8.1 SC – Smart Ceiling Panel Input

Commands:

Global name:	_PANEL_CEILING
Local name:	PANEL_CEILING
Alias:	SC (Smart Ceiling)
Space:	Layout space

Purpose:

To create ceiling panels of any shape.

Note: Smart panels are non-structural hence they are not engineered, and loads are not transferred to any frames below. The PPD/SPD command only serves the purpose of building the frame of the panels.

Process:

- Type SC then press Enter.
- If you get a 'Not initialized yet' Message in Command Bar, do the following:
 - Type 'AECOBJECTS' and set to 'ON'
 - Restart IntellCAD
 - In later versions of the software, this is done automatically, however the user will be prompted to save their job and restart the software before the setting will take effect.

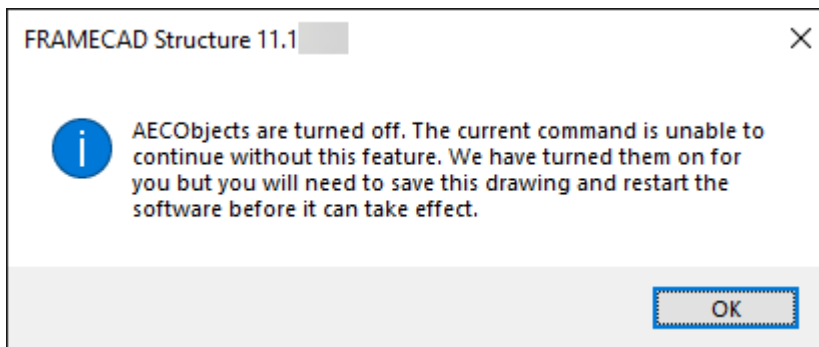

- Select 'S' to go to the Ceiling Panel settings.
- Make any required changes and save.
- Select 'P' to input panel by points.
- OR
- Select 'I' to input panel inside a polygon or closed polyline.
- Label and SPD to build separately from wall panels.
- OR
- Label and PPD to build with wall panels.
- Panels will build as Blocks.

- In the layout space, list (LI) a panel and click on the 'Press to Edit' button to edit members in the Block Editor.
- OR
- In the detail space, double click anywhere on the panel block to edit members in the Block Editor.
- 'Save Block' then 'Close Block Editor' to exit.
- If 'Close Block Editor' is selected first, the user will be prompted to save.

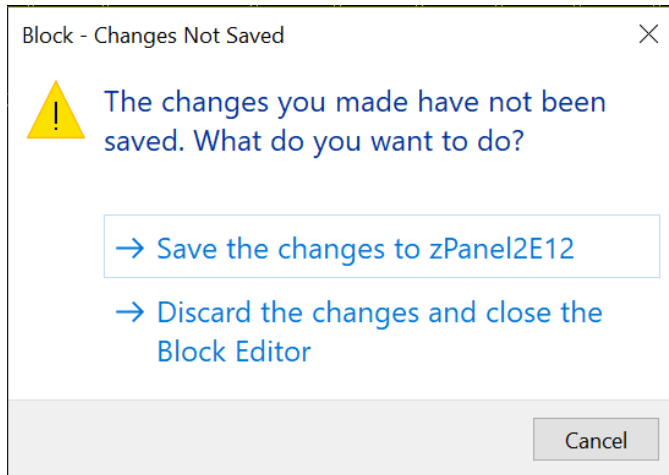

PSET - Ceiling Panel Options Information

Property	Value
<div style="border: 1px solid red; display: inline-block; padding: 2px;">Options</div>	
<div style="background-color: #f2f2f2;"> ▣ Ceiling Panel Options Information </div>	
Ceiling System	FRAMECAD_FT_m
Current Model	Default
AEC Level	Ground Floor
Noggin Spacing	1350
Panel RL	2440
Layout Colour	50
Stud Space	600
Required Shrinkage	0
Stud Type	Single Even
Noggin Type	Continuous
<div style="background-color: #f2f2f2;"> ▣ Floor Panel Options </div>	
<div style="background-color: #f2f2f2;"> ▣ Roof Panel Options </div>	
<div style="background-color: #f2f2f2;"> ▣ Stud Array Options Information </div>	
<div style="background-color: #f2f2f2;"> ▣ Notch Settings </div>	
<div style="background-color: #f2f2f2;"> ▣ Labelling Option Information </div>	
<div style="background-color: #f2f2f2;"> ▣ Detail Sheet Options </div>	
<div style="background-color: #f2f2f2;"> ▣ Panel Builder Filters </div>	

Additional Information:

How to rake (pitch) a smart panel:

- List (LI) the smart panel
- Under AEC Basics, change the '3D Raking Angle' to the desired pitch.
- Change the '2D Raking Direction' to suit the required pitch direction. The arrow indicator on the panel will change to suit.
- You can also use the PRA (Rake Panel) command to create a pitch on a smart panel.

How to add an opening into a smart panel:

- Draw a rectangle of the required size and location within the smart panel.
- Type MJ (MEMBER_JOIN) and select the panel.
- Hold the ALT key down and select the opening polyline. All framing in the opening will be subtracted from the panel.

Note: This process can also be used to create notches in the corners and edges of panels.

How to reshape a smart panel on the layout:

- In the layout, run the MD (MEMBER_DIVIDE) command
- Set the number of segments required to divide the side of a panel by (2 will add one extra grip)
- Click on the smart panel
- Once the panel is selected, then click on the segment that you need to add the extra grip(s) to.
- Select the panel to highlight the grips, then click on the grip that you wish to move.
- Stretch the grip to the required location
- Important: LI the panel and go to 'Other Tools – Rebuild Blocks' and activate the 'Press to Rebuild' button
- Now your panel is ready to send to the Panel Builder (SPD) and/or Insert Block

8.2 SR – Smart Roof Panel Input

Commands:

Global name:	_ROOFPANEL
Local name:	ROOFPANEL
Alias:	SR (Smart Roof)
Space:	Layout space

Purpose:

To create roof panels of any shape.

Note: Smart panels are non-structural hence they are not engineered, and loads are not transferred to any frames below. The SPD/PPD command only serves the purpose of building the frame of the panels.

Process:

Please refer to Ceiling Panel input.

8.3 SF – Smart Floor Panel Input

Commands:

Global name:	_FLOORPANEL
Local name:	FLOORPANEL

Alias: SF (Smart Floor)

Space: Layout space

Purpose:

To create floor panels of any shape.

Note: Smart panels are non-structural hence they are not engineered and loads are not transferred to any frames below. The PPD/SPD command only serves the purpose of building the frame of the panels.

Process:

Please refer to Ceiling Panel input.

8.4 SPD – Smart Panel Builder

Commands:

Global name: _NPANEL_BUILDER

Local name: NPANEL_BUILDER

Alias: SPD (Smart Panel Builder)

Space: Layout space

Purpose:

Exports smart panels to the 'Panel Builder'.

Process:

- From the wall framing layout, type SPD then press Enter. This will export them to the 'Panel Builder' dialogue box.
- From here the user can check each panel individually in the 'Fabrication' window (or click on the Check button to do an automatic check). Other options available here are to be able to check the quantities for each panel in the 'Bill of Materials' window, print or locate.
- Next, select the required panels and click on To Cad to export to detailing space.

Additional Information:

To export panels one layout at a time using the filter option:

Ensure that the border for the required layout is in focus.

Activate the PPD command.

Within the Panel Builder, select the 'Filters Are Off' option.

Change the 'Current View Only' option to 'True' and click on Change.

All other frames that are not within the initial screen view will be filtered out.

9 Editing Commands

9.1 AS - Add Support

Commands:

Global name:	_ TRUSS_SUPPORT
Local name:	TRUSS_SUPPORT
Alias:	AS
Space:	Detailing Space

Purpose:

To add a support point to a truss or floor joist.

Process:

Type AS then press Enter.

Select the location on a truss where the support is to be placed.

The support type (pinned, x-roller or y-roller) is automatically determined by the software according to the location and what supports already exist. A support type can be changed by listing (LI) and editing it.

Additional information:

By default, only one pinned support is applied to a truss, therefore when editing supports, please ensure that you don't end up with multiple pinned supports unless specifically required by an engineer.

9.2 BM - Box Member

Commands:

Global name:	_ TRUSS_BOX
Local name:	TRUSS_BOX
Alias:	BM
Space:	Detailing Space

Purpose:

Allows the user to fully or partially box a member to a detailed truss, floor joist or wall panel. When the command is complete, in the case of a truss, the truss is automatically re-engineered and the material summary list is automatically updated with the individual members being labelled.

Process:

- Type BM then press Enter.
- To fully box a member, click anywhere on the member to select it then right click or press Enter to finish.

Or...

- To partially box a member, select the start location of the boxing member then the finishing location.
- Partial boxing also allows a distance to be entered in as the second point.

Additional information:

- **Note:** Boxing of truss chords is not recommended therefore, holding down the 'ALT' key (as noted in the Command Bar) allows the boxing member to be placed in the alternative axis alongside the main member as a 'reinforcing member'. This must be fixed in accordance with an engineer's specification or as per the software's recommendation. The reason for not boxing chords is that the intersecting webs must have notches taken out of them so they can tab over the boxed chord. This renders the web to be unable to work in compression as the unsupported flanges will buckle under load.
- When a member has been fully boxed, the toolings are automatically updated.
- If a wall member other than a stud is boxed in the elevation view (Detailing Space), then a note is placed in the Panel Properties Editor – General Information – Redline Text to say that the wall has been amended when you list (LI) that wall in plan view.

9.3 C - Copy Member

Commands:

Global name:	_ COPY
Local name:	COPY
Alias:	C or COPY
Space:	Layout and Detailing Space

Purpose:

To copy an entity to another location.

Process:

- Type C then press Enter.
- Select the entity then right mouse click or press Enter.
- Select the location to copy the entity to by first selecting a base point then a displacement point or type in a distance.
- If Orthogonal mode is on, the selected item will only copy horizontally or vertically from its original location. Holding down the 'Shift' key will allow displacement in any direction. The opposite also applies if Ortho mode is disabled.
- Escape to exit the command.

Additional Information:

If multiple copied members are required, continue selecting displacement points, then escape to exit command.

9.4 IP - Inherit Properties

Commands:

Global name:	_MEMBER_ INHERIT
Local name:	MEMBER_ INHERIT

Alias: IP
Space: Layout and Detailing Space

Purpose:

Copies the properties from one member to another.

Process:

- Type IP then press Enter.
- Select the member you wish to copy the properties from.
- Select the member or members you wish to copy the properties to.
- Right click or press Enter to finish.

9.5 IW - Insert Web

Commands:

Global name: _TRUSS_ADDWEB
Local name: TRUSS_ADDWEB
Alias: IW
Space: Detailing Space

Purpose:

Allows the user to insert individual webs to a detailed truss. The user may add any quantity of webs desired and the type of web inserted will be the default type for that frame. If a web is over length then that web will be boxed automatically if the data file allows boxing. Fixings are automatically added to the member. When the command is complete, the truss is automatically re-engineered and the material summary list is automatically updated with the individual members being relabelled. All toolings are updated automatically.

This command also allows webs to be added to wall frames.

Process:

- Type IW then press Enter.
- Click on a chord for the start point for the web.
- Click on a chord for the finish point for the web.

Note: If ORTHO mode is on, toggle it off using the F8 key to make the second point selection.

- Right click or press Enter to place the web.
- A similar procedure is required to add webs to wall frames. See bottom of Additional Information section for wall frames.

Additional Information:

When selecting existing fixing nodes on adjacent webs as starting points and / or ending points, the software sets the starting and ending points of the newly inserted web at the correct location from the selected fixings node. The software also modifies the selected points so that the webs are inserted evenly into the truss.

If absolute web input locations are required, type 'a' after the last entry selection.

Also see: Add - Truss Members for alternative member input method. Use this option for vertical web input.

Wall Frames:

- If a member is inserted vertically (or within 5° of vertical), it will snap into place as a vertical stud member.
- If a member is inserted horizontally (or within 5° of horizontal), it will snap into place as a horizontal web member.
- If a member is inserted diagonally from a member location close to one intersection and then to another intersection, the member will snap to the selected member at a predetermined distance.

9.6 M - Move

Commands:

Global name:	_MEMBER_ MOVE
Local name:	MEMBER_ MOVE
Alias:	M or MOVE
Space:	Layout and Detailing Space

Purpose:

Moves an entity or object by given points.

Process:

- Type M or MOVE then press Enter.
- Select the entity then right mouse click or press Enter.
- Select the location to move the entity to by first selecting a base point then a displacement point or type in a distance.
- If Orthogonal mode is on, the selected item will only move horizontally or vertically from its original location. Holding down the 'Shift' key will allow displacement in any direction. The opposite also applies if Ortho mode is disabled.
- Escape to exit the command.

9.7 MB - Break Member

Commands:

Global name:	_MEMBER_ BREAK
Local name:	MEMBER_ BREAK
Alias:	MB
Space:	Layout and Detailing Space

Purpose:

Breaks multiple members or frame entities (generally joists or trusses) at a given location. This command is generally used to break multiple members along a line.

Process:

- Draw a reference line through one or more members at the break location.
- Type MB then enter.
- Select one end of the reference line then the other.
- Right click to break the members into two pieces or click on the side of the reference line that you wish to delete.

Additional Information:

Do not use this command to break raking walls. The heights will not be maintained correctly across the two panels. You should only use the MC (Member Cut) command.

9.8 MC - Cut Member

Commands:

Global name:	<code>_MEMBER_ CUT</code>
Local name:	<code>MEMBER_ CUT</code>
Alias:	<code>MC</code>
Space:	Layout and Detailing Space

Purpose:

Cuts a member or frame at a selected location. This command can only be used to cut one member or frame at a time. This command is used for:

- Breaking individual wall frames, joists and trusses
- Cutting individual members in frame elevations
- Cutting smart panels
- Splicing truss members in elevation view

Process:

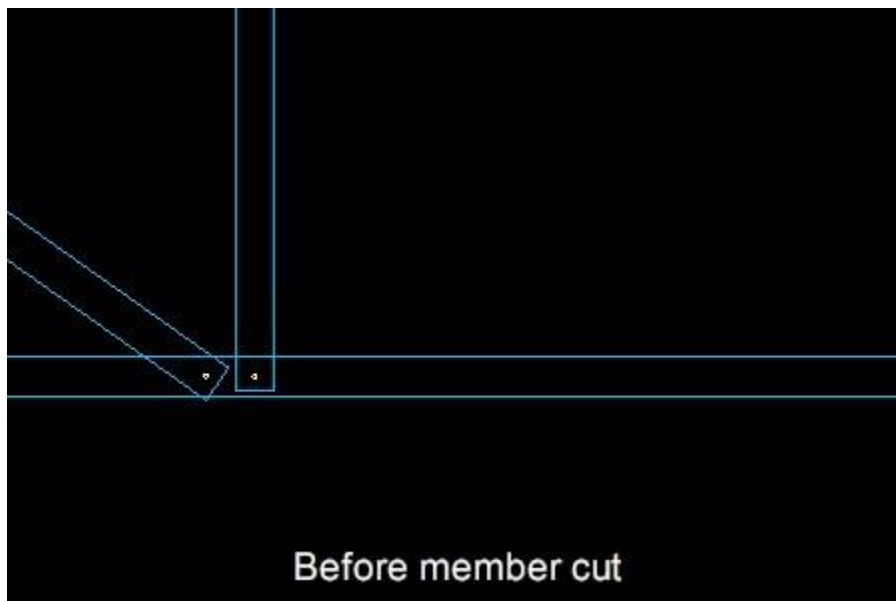

To cut members or frames:

- Type MC then press Enter.
- Select the member or frame to cut.
- Select the location to cut the member at, then right click or press Enter to complete the command.

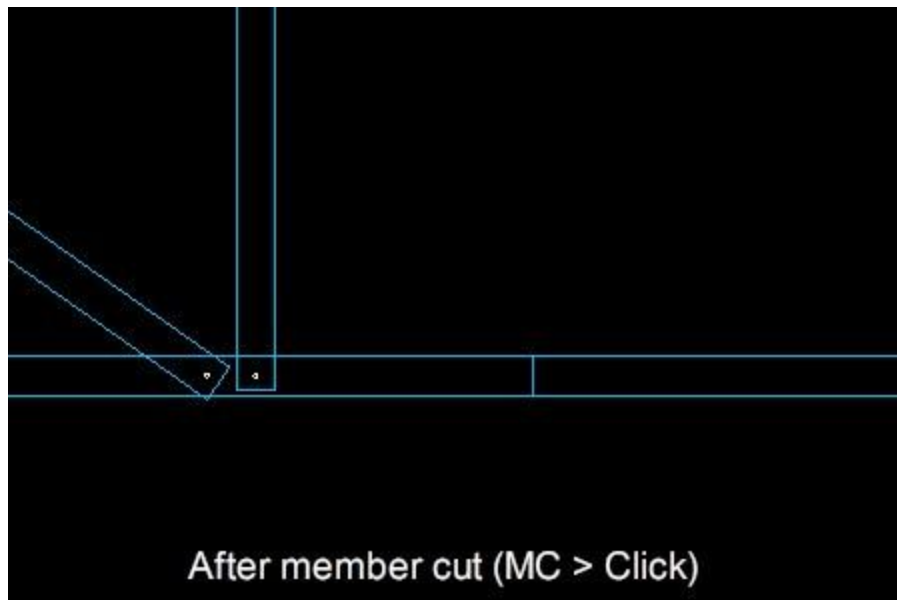

To splice truss members (in detailing space only):

- Type MC then press Enter.
- While holding down the ALT key, select the truss member at the splice location required.
- Right click or press Enter to complete the command.



9.9 MD – Member Divide

Global name:	_MEMBER_DIVIDE
Local name:	MEMBER_DIVIDE
Alias:	MD
Space:	Layout and Detailing Space

Purpose:

Allows frames or members to be equally divided into a set number of pieces, or equally divided into pieces set to a maximum specified length.

Process:

- Type MD then press Enter
- In 'Q' - Quantity Mode – specify the number of segments required.
- Select member to break
- In 'D' – Distance Mode – specify the maximum length of segments required.
- Select member to break

9.10 ME - Extend Member

Commands:

Global name:	_MEMBER_EXTEND
Local name:	MEMBER_EXTEND
Alias:	ME
Space:	Layout and Detailing Space

Purpose:

Extends or trims one member to another selected member.

Process:

- Type ME then press Enter.
- Select the member to extend to.
- Select the member or members to extend then right click to finish.

Additional Information:

This command can also be used to trim an overlapping member back to the member to extend to.

9.11 MF - Fillet Member

Commands:

Global name:	_MEMBER_FILLET
--------------	----------------

Local name:	MEMBER_FILLET
Alias:	MF
Space:	Layout and Detailing Space

Purpose:

To edit the lap order of two members or frames.

Process:

- Type MF then press Enter.
- Select the dominant frame or member.
- Select the second frame or member and right click to re-order and finish.

9.12 MI - Mirror

Commands:

Global name:	_PANEL_MIRROR
Local name:	PANEL_MIRROR
Alias:	MI
Space:	Layout and Detailing Space

Purpose:

Moves or copies the reflected image of selected entities about a line.

This command is an improvement on the standard CAD mirror command with greater intelligence built in. It operates in two distinct modes. If the first item selected is a web of a truss, window head, webbed beam or webbed floor member, then it will operate in 'Mirror Web' mode. If the first item selected is anything but a web then it will operate as a simple mirror command.

Process:

- Type MI then press Enter.
- Select the entities you want to mirror, and then press 'Enter'.

Mirror Web Mode:

In 'Mirror Web' mode there is no need to select anything else except the webs. The software will automatically select any associated parts, fixings and hatch's associated with the webs. When the user is prompted to select a point for the mirror plane, only one point is required as the software assumes that the point will be mirrored around the vertical plane. When selecting the mirror point, the snap mode is automatically set to 'mid', however the user may select or override this as required. When the command is complete, the snap mode will return to whatever it was before the command was run.

If the webs selected were associated with a truss, then when the command is completed, the truss will be automatically re-engineered and the cutting lists will be updated. If the webs selected were a wall frame or a floor joist, then the cutting list will be updated only.

Simple Mirror Mode:

In 'Simple Mode' the operator is given two simple choices as to whether to delete the original entities or not. This choice then determines how the entities will be handled. When selecting trusses from a truss layout there is no need to select other associated parts such as direction marker or eaves as the software will get these items for you. Same applies to openings, there is

no need to select the opening text as the software will automatically select this for you. However, when selecting a wall panel from a layout, it will not automatically select the studs, bracing, etc. It is left to the user to decide on what to select.

Delete Original Entities:

When using this option, the software does very little, it basically just checks the orientation of various items. There is also no need to select the label text of trusses, walls, openings or floors from a layout. The software will do this for you.

Retaining Original Entities:

With this method, truss labels, wall labels and floor labels are not mirrored. The reason for this is that in almost all cases a global relabelling will be required. On completion of this mode, most of the on-page reports are automatically updated.

9.13 MJ - Join Members

Commands:

Global name:	_MEMBER_JOIN
Local name:	MEMBER_JOIN
Alias:	MJ
Space:	Layout and Detailing Space

Purpose:

To join two adjoining members.

Process:

- Type MJ then press Enter.
- Select both members to join.
- Right click or press Enter to finish.

Additional Information:

If the two members are not adjoining or in the same plane, then a new member will be drawn from the furthest points of the members selected.

With this command, it does not matter which end of each member is selected as the new member will be drawn from the furthest points of the members selected. This routine will work on all 'trace' entities.

9.14 ML - Lengthen

Commands:

Global name:	_MEMBER_LENGTHEN
Local name:	MEMBER_LENGTHEN
Alias:	ML or LEN
Space:	Layout and Detailing Space

Purpose:

To lengthen or shorten a member, frame or line by a given distance.

Process:

- Type ML then Press Enter.
- Type in the required length (type in a negative number to shorten a member/frame/line).
- Click close to the end of the member/frame/line to be shortened.

9.15 MO - Offset Member

Commands:

Global name:	_MEMBER_OFFSET
Local name:	MEMBER_OFFSET
Alias:	MO
Space:	Layout and Detailing Space

Purpose:

Offsets a parallel copy of an entity or object by a given distance.

Process:

- Type MO then press Enter.
- Enter the distance to offset by.
- Select the entity to offset.
- Click on the side of the entity that you wish to offset to.
- Press Escape to exit the command.

Additional Information:

- When using the MO command for walls or wall beams, the distance applied is the distance in between members.
- When using the MO command for trusses or joists, the distance applied is the distance from centre to centre of members.

9.16 MP – Match Properties

9.17 MR - Reverse Member

Commands:

Global name:	_PANEL_REVERSE
Local name:	PANEL_REVERSE
Alias:	MR or RF (Reverse Frame)
Space:	Layout Space

Purpose:

Reverses the direction of any member.

Process:

- Type MR then press Enter.
- Select the member to reverse then right click or Enter.

9.18 MU - Update Member (Previously MS – Member Resquare)

Commands:

Global name:	_MEMBER_UPDATE
Local name:	MEMBER_UPDATE
Alias:	MU (Member Update)
Space:	Detailing Space

Purpose:

Updates truss chords and webs, joist webs or wall lintel webs after editing.

Re-populates missing member connection screws in trusses, webbed joists and walls.

Process:

- Type MU then press Enter.
- Select a member to update.
- Right click or press Enter to finish.
- All other webs in the frame (and chords in trusses) will also be updated and member connection screws re-populated.
- Note: The end of a web must be located within the edge of the member it is connected to before the MU command will work.

9.19 MX - Trim Crossing Members

Commands:

Global name:	_MEMBER_CROSS
Local name:	MEMBER_CROSS
Alias:	MX
Space:	Layout and Detailing Space

Purpose:

Breaks one member or frame either side of another crossing member or frame.

Process:

- Type MX then press Enter.
- Select the member/frame to cut first.
- Select the continuous member/frame second. Right click or press Enter to finish.

9.20 RF - Reverse Frame

Commands:

Global name:	_PANEL_REVERSE
Local name:	PANEL_REVERSE
Alias:	RF or MR (Reverse Member)
Space:	Layout Space

Purpose:

Reverses the direction of a frame entity.

Process:

- Type RF then press Enter.
- Select the frame then right click or Enter to reverse its direction.

9.21 SE - Special Erase

Commands:

Global name:	_LAYOUT_ERASE
Local name:	LAYOUT_ERASE
Alias:	SE
Space:	Layout and Detailing Space

Purpose:

Erases all trusses and smart panels on a roof truss layout; all joists in a floor framing layout; all wall studs on a wall frame layout, or selected joists, trusses, wall studs or truss webs.

Method:

Type SE then press Enter.

Select a truss or joist.

Right click or Enter to perform a global erase of all joists or trusses from that plan or select individual joists or trusses to erase.

For wall framing, this command only allows for the deletion of studs within walls - does not delete walls themselves.

For truss webs - in Detailing Space - selecting a web will erase web label and dimples. Will also globally delete all webs within a truss.

9.22 STRIP - Strip Entity Property Intelligence

Commands:

Global name:	_STRIP
Local name:	STRIP
Alias:	

10 Dimension Commands

10.1 DA - Aligned Dimension

Commands:

Global name:	_ DIMENSION_ ALIGNED
Local name:	DIMENSION_ ALIGNED
Alias:	DA
Space:	Layout and Detailing Space

Purpose:

To input dimensions aligned between two points.

Process:

- Type DA then press Enter.
- Select the dimension location.
- Select the points you wish to dimension then right click or enter to finish.
- When selecting points to dimension, the cursor has been set to pick end points or intersections. This routine will dimension at whatever angle the second point is from the first.

10.2 DH - Horizontal Dimension

Commands:

Global name:	_ DIMENSION_ HORIZONTAL
Local name:	DIMENSION_ HORIZONTAL
Alias:	DH
Space:	Layout and Detailing Space

Purpose:

To input a series of running ordinate dimensions from a given reference point. It will only dimension using the 'X' coordinates.

Process:

- Type DH then press Enter.
- Select the location where you want the dimensions to appear.
- Continue selecting points to dimension then right click or enter to finish.
- The first point selected will be considered to be '0', the rest of the points will be set from this point.

10.3 DL - Line Dimension

Commands:

Global name:	_ DIMENSION_ LINE
--------------	-------------------

Local name:	DIMENSION_LINE
Alias:	DL
Space:	Layout and Detailing Space

Purpose:

To dimension the length of a selected line segment. It is a simple routine which labels the length of each segment of the line. It is a very useful routine for producing a simplified concrete slab set out.

Process:

- Type DL then press Enter.
- Select the lines to be dimensioned then right click or enter to finish. Any polylines selected will be exploded into individual lines.

10.4 DM - Dimension Members

Commands:

Global name:	_ DIMENSION_LINEAR
Local name:	DIMENSION_LINEAR
Alias:	DM
Space:	Layout and Detailing Space

Purpose:

To dimension multiple member or frame entity locations.

Process:

- Type DM then press Enter.
- Click on the dimension location.
- Select the entities to be dimensioned then right click or enter to finish. A right to left fence selection can be used to select multiple members at once.

10.5 DO - Ordinate Dimension

Commands:

Global name:	_ DIMENSION_ORDINATE
Local name:	DIMENSION_ORDINATE
Alias:	DO
Space:	Layout and Detailing Space

Purpose:

To produce a series of running ordinate dimensions from a given reference point.

Process:

- Type DO then press Enter.

- Select an approximate location outside the end of the building where you want the dimensions to start from and in line with where you want the ordinate dimension leader lines to start from.

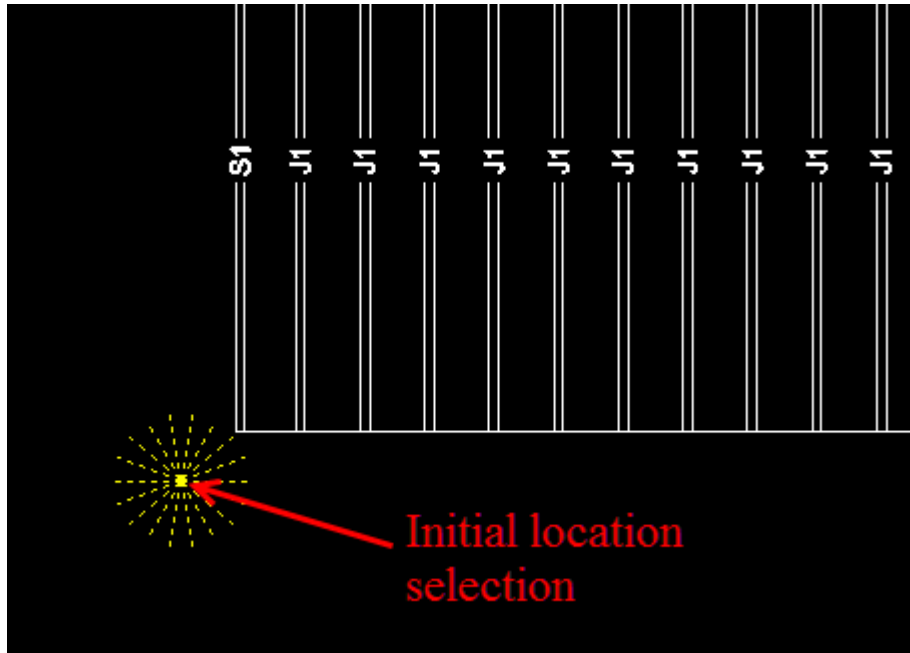

- Select the first entity (or a reference line) from where the dimensions are to start from. The first point selected will be considered to be '0', the rest of the points will be set from this point.

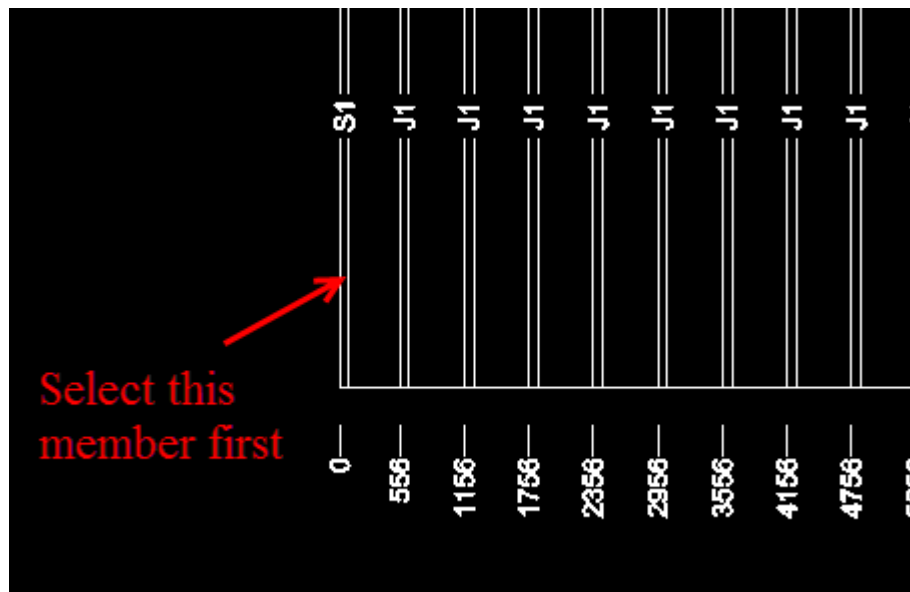

- Continue selecting entities to dimension then right click or enter to finish. A right to left fence selection can be used to select multiple members at once.

Additional Information:

Ordinate dimension can be set to dimension to the front, centre or back of entities by changing the settings in BSET | Options | Dimension Options.

10.6 DV - Vertical Dimension

Commands:

Global name: _ DIMENSION_ VERTICAL
Local name: DIMENSION_ VERTICAL
Alias: DV
Space: Layout and Detailing Space

Purpose:

To input a series of running ordinate dimensions from a given reference point. It will only dimension using the 'Y' coordinates.

Process:

- Type DV then press Enter.
- Select the location where you want the dimensions to appear.
- Continue selecting points to dimension then right click or enter to finish.
- The first point selected will be considered to be '0', the rest of the points will be set from this point.

11 Report Commands

The standard on page design report is created automatically when a wall, joist or truss layout is created. OR will update existing reports or replace missing reports.

Other reports can be found in the Panel Editor (Bill of Materials, Stud Design), Joist Builder (Bill of Materials) and Truss Editor (Bill of Materials, Engineering and Results). These reports can be printed.

11.1 JOA – On Page Joist Accessories Report

Commands:

Global name:	_ JOIST_ACCESSORIES
Local name:	JOIST_ACCESSORIES
Alias:	JOA
Space:	Layout Space

Purpose:

To create an on-page report displaying the floor accessories.

Process:

- Ensure the floor layout plan border is in focus on the screen.
- Type JOA then press Enter.
- The on-page report is automatically placed in the top-right corner of the layout border.

Note: quantities here are not rounded up.

11.2 OR - On Page Summary

Commands:

Global name:	_ ONPAGE_REPORT
Local name:	ONPAGE_REPORT
Alias:	OR
Space:	Layout and Detailing Space

Purpose:

Creates an on-page wall panel design summary.

Creates an on-page truss design summary.

Creates an on-page floor member quantity list summary (size, quantity, length).

Creates an on-page floor sheet quantity list summary.

Updates or creates a detailed wall panels on-page cutting list.

Updates or creates a detailed truss on-page cutting list.

Updates or creates a detailed floor beam on-page cutting list.

Updates or creates floor sheeting on-page summary.

Updates or creates floor layout on-page summary.

Updates or creates or creates roofing materials on-page summary.

Updates or creates truss on-page accessories summary.

Process:

- Ensure the plan or detailed elevation (for material update) for the desired report is in focus on the screen.
- Type OR then press Enter.

11.3 POA – On Page Panel Accessories Report

Commands:

Global name: _ PANEL_ACCESSORIES

Local name: PANEL_ACCESSORIES

Alias: POA

Space: Layout Space

Purpose:

To create an on-page report displaying the wall accessories.

Process:

- Ensure the wall framing plan border is in focus on the screen.
- Type POA then press Enter.
- The on-page report is automatically placed in the top-right corner of the layout border.

Note: quantities here are not rounded up.

11.4 POB - On Page Beam Report

Commands:

Global name: _ ONPAGE_BEAM

Local name: ONPAGE_BEAM

Alias: POB

Space: Layout Space

Purpose:

Places a summary list of beams on the plan.

Process:

- Type POB then press Enter.
- Type 'L' to snap input to top left-hand corner, 'R' to snap input to top right-hand corner, or 'M' to snap input to the middle.
- Select location to place report.

11.5 POO - On Page Opening Report

Commands:

Global name:	_ ONPAGE_OPENINGS
Local name:	ONPAGE_OPENINGS
Alias:	POO
Space:	Layout Space

Purpose:

Places a summary list of openings on the plan.

Process:

- Type POO then press Enter.
- Type 'L' to snap input to top left-hand corner, 'R' to snap input to top right-hand corner, or 'M' to snap input to the middle.
- Select location to place report.

Additional Information:

Column 1 shows the library/input method used (this ensures that the correct opening library has been used).

Column 2 shows the height.

Column 3 shows the width.

Column 4 shows the quantity.

11.6 POP - On Page Post Report

Commands:

Global name:	_ ONPAGE_POSTS
Local name:	ONPAGE_POSTS
Alias:	POP
Space:	Layout Space

Purpose:

Places a summary list of posts on the plan.

Process:

- Type POP then press Enter.
- Type 'L' to snap input to top left-hand corner, 'R' to snap input to top right-hand corner, or 'M' to snap input to the middle.
- Select location to place report.

11.7 POS - On Page Panel Report

Commands:

Global name:	_ ONPAGE_PANEL
--------------	----------------

Local name:	ONPAGE_PANEL
Alias:	POS
Space:	Layout Space

Purpose:

Places a summary list of panels on the plan which contains panel quantities and total length of wall types.

Process:

- Ensure the wall framing plan border is in focus on the screen.
- Type POS then press Enter.
- Type 'L' to snap input to top left-hand corner, 'R' to snap input to top right-hand corner, or 'M' to snap input to the middle.
- Select location to place report.

11.8 RA – On Page Roof Area Report

Commands:

Global name:	_ROOF_AREA
Local name:	ROOF_AREA
Alias:	RA
Space:	Layout Space

Purpose:

To obtain a roof area report.

Process:

- Ensure the correct roof pitch is set in the truss settings (TSET)
- Type RA then press Enter or right mouse click.
- Select the points which determine the perimeter of a roof then Enter or right click.
- Select a location to place the report.

11.9 REP - Report

Commands:

Global name:	_REPORT
Local name:	REPORT
Alias:	REP
Space:	Layout and Detailing Space

Purpose:

In layout space, reports a range of model properties (Framing Construction Accessories, Engineering Summary Outputs, Cladding Geometric parameters). Outputs vary for each sub-assembly type (Walls, Roof, Floor).

In detailing space, reports a range of frame material reports. Outputs vary for each frame type (Panel, Truss, Joist).

Process:

- Make sure the relevant layout is in focus.
- Type REP then press Enter.

Additional Information:

Panel layout space report:

View, Print or Export a csv file from the Panel Layout Report. Options include Openings, Reactions, Loads, Accessories and Statistics reports (Statistics report includes bottom plate lengths, wall surface square areas, wall perimeters and hold down quantities).

Note: quantities are rounded up based on the rounding quantities as set in the data file, e.g. screws are rounded to the nearest 50 when using the default FRAMECAD_FT data files.

Beams and posts included and show RL heights.

The 'Statistics' tab provides the following information when a report is generated from the wall framing layout:

- A list of panel types showing location, floor type, quantity, total length, total area and total perimeter
- The same statistics for the openings
- Bracing quantities and lengths
- Hold-down quantities
- Beam summary.

Panel detailing space report:

View, Print or Export a csv file from the Panel Usage Reports. Options include Panel Report, Material Report and Summary Report.

Truss layout space report:

View, Print or Export a csv from the Truss Layout Report. Options included are Truss Accessories, Engineering Status and Truss Uplift Reactions.

Truss detailing space report:

View, Print or Export a csv from the Truss Usage Report. Options included are Truss Report, Material Report, Summary Report and Engineering Status.

Joist layout space report:

View, Print or Export a csv from the Floor Layout Report. Options included are Member Report, Sheet Report, Batten Report and Accessories Report.

Joist detailing space report:

View, Print or Export a csv from the Floor Usage Report. Options include Beam Report, Material Report and Summary Report.

11.10 TOA – On Page Truss Accessories Report

Commands:

Global name:	_ TRUSS_ACCESSORIES
Local name:	TRUSS_ACCESSORIES
Alias:	TOA

Space: Layout Space

Purpose:

Adds an on-page report for the truss accessories to the truss layout.

Process:

- Type TOA then press Enter.
- The accessory report is automatically added to the top right corner of the truss layout plan border.

Note: quantities here are not rounded up.

11.11 **TOS – On Page Truss Summary**

Commands:

Global name: _ONPAGE_SUMMARY

Local name: ONPAGE_SUMMARY

Alias: TOS

Space: Layout Space

Purpose:

Provides a list showing the total lineal quantity of each truss type.

Process:

- In the truss layout, Type TOS then right click or press Enter.
- Click on a location within the border to place the report.

11.12 **SUM – Report Summary**

Commands:

Global name: _SUMMARY

Local name: SUMMARY

Alias: SUM

Space: Layout Space

Purpose:

Provides a material Site Summary, Manufacturing Summary and L-Plate Summary report for all the individual detail sheet tabs.

Process:

- In the Layouts tab, Type SUM then right click or press Enter.

Additional Information:

Site Summary

- Displays quantities of frames and total lineal material quantities.
- Displays quantities of battens and total lineal quantities.
- Displays quantities of site fixings and fasteners

Manufacturing Summary

- Displays quantities and weights for material used for site manufactured frames for each detail sheet tab.
- Displays full job summary of materials and weights for site manufactured frames.

L-Plate Summary

- Displays all lintel plate information for each detail sheet tab.

All information can be printed and/or export as a CSV file.

12 Viewing Commands

12.1 A3D (or 3D) - Full Layout 3D

Commands:

Global name:	_LAYOUT_3D
Local name:	LAYOUT_3D
Alias:	A3D or 3D
Space:	Layout Space

Purpose:

Creates a full wire frame view of the floor, walls and trusses.

Process:

- From within the Layout space type A3D then press Enter.
- A 3D view of walls, joists and trusses will be created in the Model space.
- Either select a preset viewpoint from the View menu or hold the CTRL key down and use your mouse to rotate the plan.
- Select Plan View from the View menu to revert back to the original plan view. Right click or press Enter to complete the command.
- Type A3D then press Enter to toggle the 3D view on or off.





Additional Information:

Changing to Isometric and Orthographic Views:

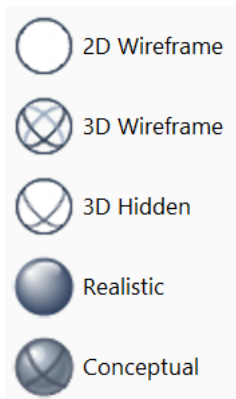
Viewing angle can be changed easily by using the VV (Next 3D View) command or selecting a preset viewpoint; use following steps:

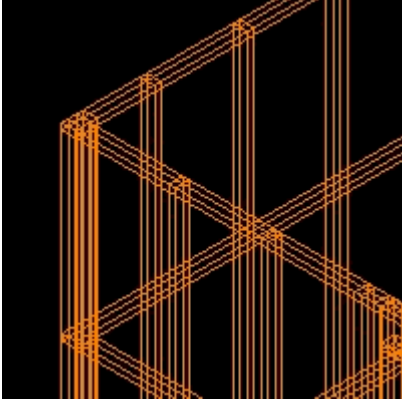
- Click on View – 3D Views on menu bar or from the View ribbon menu.
- Changing Visual Style:
- Click on View – Visual Styles on menu bar or from the View ribbon menu.
- Click on one of the following icons, 3 in the middle are mostly used

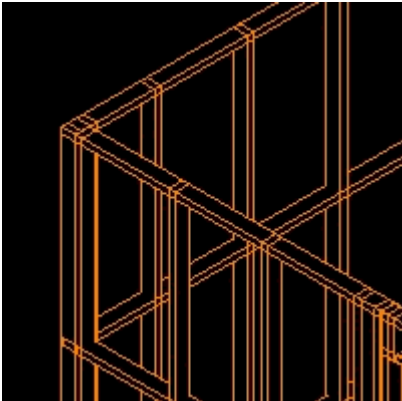

	3D Wireframe	Generates 3D wireframe model turning all surfaces transparent, showing all edges and folds as lines	
	3D Hidden Alias = HI	Generates 3D model turning all surfaces opaque, hiding all edges and folds that are behind any surface	
	Realistic	Generates 3D realistic model showing all surfaces in colour and in different shades for XY, YZ and ZX planes	

12.2 J3D - Floor Joist 3D

Commands:

Global name: _FLOOR_3D

Local name: FLOOR_3D

Alias: J3D

Space: Model space

Purpose:

Creates a 3D of the floor joists or selected floor joists only.

Process:

- From within the Layout space type J3D then press Enter.
- Press enter again for a global selection or select just the joists that you wish to 3D.
- A 3D view of the joists is created in the Model space.
- Type J3D then press Enter to toggle the 3D view on or off.

Additional Information:

To view deep C joists as more realistic 'c' shaped members, first you need to send the joists to CAD using JJD, otherwise they will only appear as rectangular oblongs.

Viewing angle can be changed easily by using the VV (Next 3D View) command.

To select a pre-set viewpoint see **A3D**.

12.3 P3D - Panel 3D

Commands:

Global name:	_PANEL_3D
Local name:	PANEL_3D
Alias:	P3D
Space:	Layout space & Model space

Purpose:

Creates a 3D of the walls only.

Process:

- From within the Layout space type P3D then press Enter.
- Press enter again for a global selection or select just the walls that you wish to 3D.
- A 3D view of the walls is created in the Model space.
- Type P3D then press Enter to toggle the 3D view on or off.

Additional Information:

Viewing angle can be changed easily by using the VV (Next 3D View) command.

To select a pre-set viewpoint see **A3D**.

12.4 R3D – Roof Plane 3D

Commands:

Global name:	_ROOF_3D
Local name:	ROOF_3D
Alias:	R3D
Space:	Model space

Purpose:

Allows a 3D roof plane to be manually created in the model space.

Process:

- Copy the roof lines from the roof layout to the same co-ordinates in Model space (refer to [SETREF – Set 3D Marker in Model Space](#) in the General Section).
- From within the Model space type R3D then press Enter.
- The available command bar options are:
 - P = Point selection input method (allows you to select the outside points of the roof plane).
 - I = Island input method (allows you to select anywhere within bounding lines).
 - S = Opens the TSET settings if required.
- Using the P (Points) input method, select the required roof line points and right click to finish.
- Then select the start and end points of the pitching line. If the first two points selected during the roof plane input are the pitching line, then right click to bypass this option.
- You are then asked to select a third point of reference for the upward direction of the slope.

Additional Information:

You can now list (LI) the roof panel if you need to alter the pitch or the height.

12.5 T3D - Truss 3D

Commands:

Global name:	_TRUSS_3D
Local name:	TRUSS_3D
Alias:	T3D
Space:	Layout space & Model space

Purpose:

Creates a 3D of the trusses only.

Process:

- From within the Layout space type T3D then press Enter.
- Press enter again for a global selection or select just the trusses that you wish to 3D.
- A 3D view of the trusses is created in the Model space.
- Type T3D then press Enter to toggle the 3D view on or off.

Additional Information:

Viewing angle can be changed easily by using the VV (Next 3D View) command.

To select a pre-set viewpoint see **A3D**.

12.6 S3D – Smart Panel 3D

Commands:

Global name:	_SMART_3D
Local name:	SMART_3D

Alias: S3D
Space: Layout space & Model space

Purpose:

Creates a 3D of the smart panels only.

Process:

- From within the Layout space type S3D then press Enter.
- Press enter again for a global selection or select just the panels that you wish to 3D.
- A 3D view of the panels is created in the Model space.
- Type S3D then press Enter to toggle the 3D view on or off.

Additional Information:

Viewing angle can be changed easily by using the VV (Next 3D View) command.

To select a pre-set viewpoint see **A3D**.

12.7 TEMPHIDE

Commands:

Global name: _TEMPHIDE
Local name: TEMPHIDE
Alias:
Space: Layout and Detailing Space

Purpose:

Allows user to temporarily hide a selected entity.

Process:

- Type TEMPHIDE then press Enter.
- Select the entity (or entities) that you wish to hide.
- To show entities again, simply run the command again and type 'S' to show.

12.8 V - Go to View...

Commands:

Global name: _VIEW_GOTO
Local name: VIEW_GOTO
Alias: V
Space: Layout and Detailing Space

Purpose:

Allows user to jump to any view.

Process:

- Type V then press Enter.
- Type the number of the view you wish to jump to.

12.9 VM - Make View

Commands:

Global name:	_VIEW_MAKE
Local name:	VIEW_MAKE
Alias:	VM
Space:	Layout and Detailing Space

Definition of a View: 2 points in space diagonally opposite each other that define a viewing area on the screen.

Purpose:

- Create a new view within a drawing. This is handy if you have drawn a detail outside of the standard borders that you wish to refer to periodically.
- Create a new border in an elevation tab for the purposes of adding a new frame.
- Updates an existing view within a drawing. This is an important step in the process of changing a frame and re-exporting it to use to update a previously exported frame.
- Repair views.

Process:

When creating a new view:

1. Type VM then press Enter.
2. Enter a name or number for the view.
3. Select the view area by clicking on 2 points diagonally opposite each other.

When updating a frame:

Use these steps to update a wall, joist or truss frame in the detailing space.

This assumes that the wall, joist or truss frames have already been built and you need to rebuild one or more frames but don't want to re-export all the frames again. This could be because too much editing has already been carried out on a number of the existing frames.

1. Re-export the required frame(s) to a new tab.
2. Copy the new frame to the initial tab containing the original frame.
3. Delete the old frame and move the new one into its place.
4. Type VM then press Enter.
5. Enter the number of the border view.
6. Select the view area by selecting 2 diagonally opposite corners of the border.

When repairing views:

The 'Repair' option repairs views that have been added, deleted or moved by the user and maybe causing issues.

- Deletes vacant views and updates any out of sequence remaining views.
- Resets tabs with Walls, Trusses or Joists to the correct type.

1. Type VM then press Enter.
2. Type R then press Enter.

Additional Information:

Copy a border to a new location if you wish to use a border as your new view and select this as your new view area.

12.10 VR - Restore View

Commands:

Global name:	_VIEW_RESTORE
Local name:	VIEW_RESTORE
Alias:	VR
Space:	Layout and Detailing Space

Purpose:

Jumps to the first drawing border in layout or detailing space.

Process:

Type VR then press Enter.

12.11 VV - View Next

Commands:

Global name:	_VIEW_NEXT
Local name:	VIEW_NEXT
Alias:	VV
Space:	Layout and Detailing Space

Purpose:

Scrolls sequentially to the next view.

Process:

- Type VV then press Enter.
- Continue to press Enter to scroll through subsequent views.
- To go back to previous views, type X.

12.12 VV - Next 3D View

Commands:

Global name:	_VIEW_NEXT
--------------	------------

Local name: VIEW_NEXT
Alias: VV
Space: Model Space

Purpose:

Toggles between pre-set viewpoints of a 3D view in the Model Space.

Process:

- Create a 3D model using one or more of the 3D create commands. See: J3D, P3D, T3D, S3D.
- From within the Model space type VV then press Enter.
- Continue entering the command to simultaneously toggle through the various views.

12.13 VVD – 3D Views

Commands:

Global name: _VVD
Local name: VVD
Alias: VVD
Space: Model Space or Detailing Space

Purpose:

Creates a new tab with 4x different isometric 3D views of your building from the Model.

Process:

- Create your 3D in Model Space using either the A3D, T3D, P3D, J3D or S3D commands.
- Run the VVD (3D Views) command from anywhere within the job.
- A new tab will be created called 3D Views. This will have four borders showing the four different aerial isometric views from the 3D that is generated in Model Space.

12.14 X - View Previous

Commands:

Global name: _X
Local name: X
Alias: X
Space: Layout and Detailing Space

Purpose:

Scrolls sequentially to the previous view.

Process:

- After scrolling through views using VV, type X then press Enter.
- Continue to press Enter to scroll through preceding views.

12.15 ZZ - Layout/Detailing Space Toggle

Commands:

Global name:	_NEXTTAB
Local name:	NEXTTAB
Alias:	ZZ
Space:	Layout and Detailing Space

Purpose:

Toggles between the Layout space and last viewed detailing space.

Process:

Type ZZ then press Enter.

Additional Information:

If you are in a detailing space tab, this command will toggle between that tab and the Layouts space tab.

If you are in the Layouts space tab, this command will toggle between that tab and the last detailing space tab selected.

13 Layer Commands

13.1 CL - Copy Layer

Commands:

Global name:	_LAYER_COPY
Local name:	LAYER_COPY
Alias:	CL
Space:	Layout Space

Purpose:

The purpose of this command is to copy layers from one layout border to another. It only works in the layout drawing space and will not work anywhere else. If a border is not found within the centre point of a screen then it will not work. If the second point selected is not within a different border then it will not work either.

Process:

- Ensure the source border is in focus.
- Type CL then right click or press Enter.
- Select one item of a layer(s) to be copied. View zooms out to display all the borders.
- Click within a border to copy the layer(s) to.

13.2 IL - Isolate Layer

Commands:

Global name:	_LAYER_ISOLATE
Local name:	LAYER_ISOLATE
Alias:	IL
Space:	Layout and Detailing Space

Purpose:

Isolates a selected layer.

Process:

- Type IL then enter.
- Click on an entity that belongs to the layer you wish to isolate.

13.3 LC - Current Layer

Commands:

Global name:	_LAYER_CURRENT
Local name:	LAYER_CURRENT
Alias:	LC

Space: Layout and Detailing Space

Purpose:

Selects layer to make current.

Process:

- Type LC then press Enter.
- Select an object belonging to the layer that you wish to make current.

13.4 LE - Erase Layer

Commands:

Global name: _LAYER_ERASE

Local name: LAYER_ERASE

Alias: LE

Space: Layout and Detailing Space

Purpose:

To erase a selected layer or objects within a selected layer.

Process:

- Type LE then press Enter.
- Select an entity from the layer you wish to erase.
- If you wish to erase all objects within the layer, press Enter again.
- If you wish to only erase selected objects within the layer, select them individually or by dragging a fence over them. Objects from any other layers will not be selected.
- Right click or press Enter to finish.

Additional Information:

This command allows multiple layers to be erased at once.

13.5 LF - Freeze Layer

Commands:

Global name: _LAYER_FREEZE

Local name: LAYER_FREEZE

Alias: LF or FL

Space: Layout and Detailing Space

Purpose:

Freezes a selected layer. Entities drawn on frozen layers do not display, do not print, and do not regenerate. When you freeze a layer, its entities do not affect the display or printing of other entities. For example, entities on frozen layers do not hide other entities when you use the Hide command to remove hidden lines. In addition, you cannot draw on a frozen layer until you thaw it, and you cannot make a fro-zen layer current.

You cannot freeze the current layer. If you attempt to freeze the current layer, a dialogue box appears prompting you to specify a different layer. You also cannot freeze or thaw a viewport layer unless you are working in a Layout tab.

Process:

- Type LF then press Enter
- Select an object to freeze the layer on which the object belongs to

Additional Information:

This command allows multiple layers to be frozen at once.

13.6 LS - Show All Layers

Commands:

Global name:	_LAYER_ALL
Local name:	LAYER_ALL
Alias:	LS (Layer Show)
Space:	Layout and Detailing Space

Purpose:

Turns on all frozen layers.

Process:

- Type LS then press Enter.
- All frozen layers will be thawed.

13.7 LT - Toggle Temporary Layer On/Off

Commands:

Global name:	_LAYER_SHOW / _LAYER_SHOW1 / _LAYER_SHOW2 / _LAYER_SHOW3 / _LAYER_SHOW4 / _LAYER_SHOW5
Local name:	LAYER_SHOW / LAYER_SHOW1 / LAYER_SHOW2 / LAYER_SHOW3 / LAYER_SHOW4 / LAYER_SHOW5
Alias:	LT / LT1 / LT2 / LT3 / LT4 / LT5
Space:	Layout and Detailing Space

Purpose:

Toggles the temporary layer (Temp_Layer) on or off. If the Temp_layer does not already exist, the command will prompt the user to select entities to add to the toggle layer. This can also be done using the LX, LX1, etc. (Layer_Add) commands.

Process:

- Type LT then press Enter.
- If temp_layer has already been created and is displayed, it will turn off.
- If temp_layer has already been created and is not displayed, it will turn on.
- If temp_layer does not exist, select entities to add and right click or press Enter to finish.

Additional Information:

LT1 toggles on or off the second temporary layer created using LX1.

LT2 toggles on or off the third temporary layer created using LX2.

LT3 toggles on or off the fourth temporary layer created using LX3.

LT4 toggles on or off the fifth temporary layer created using LX4.

LT5 toggles on or off the sixth temporary layer created using LX5.

Temporary layer can be turned on or off while inputting walls using the Panel Draw (PD) command without having to exit out of the wall input command.

Warning: Never put Steelwise entities into temp layers. Doing so will disable any intelligence required for engineering purposes and other important functionality.

13.8 LX - Add Layer

Commands:

Global name:	<code>_LAYER_ADD / _LAYER_ADD1 / _LAYER_ADD2 / _LAYER_ADD3 / _LAYER_ADD4 / _LAYER_ADD5</code>
Local name:	<code>LAYER_ADD / LAYER_ADD1 / LAYER_ADD2 / LAYER_ADD3 / LAYER_ADD4 / LAYER_ADD5</code>
Alias:	<code>LX / LX1 / LX2 / LX3 / LX4 / LX5</code>
Space:	Layout and Detailing Space

Purpose:

Adds a temporary layer (Temp_Layer / Temp_Layer1 / Temp_Layer2 / Temp_Layer3 / Temp_Layer4 / Temp_Layer5).

Process:

- Type LX then press Enter.
- Select entities to put into the temporary layer (Temp_Layer).
- Right click or press Enter to finish.

Additional Information:

These temporary layers are what is known as toggle layers. Use the LT, LT1, etc. (Show_Layer, Show_Layer1, etc.) command to toggle the temporary layers on or off.

Warning: Never put Steelwise entities into temp layers. Doing so will disable any intelligence required for engineering purposes and other important functionality.

13.9 VC - Visual Controls

Commands:

Global name:	<code>_VISUAL</code>
Local name:	<code>VISUAL</code>
Alias:	<code>VC</code>
Space:	Layout and Detailing Space

Purpose:

Allows the user to turn layers on or off easily.

Process:

- Type VC then press Enter.
- From the Visual Controls dialogue box untick any layers to be turned off.

Additional Information:

- Click on the Press to Lock Job button to lock all labels.
- Click again to unlock job.

14 How To's (and other general information)

14.1 General

14.1.1 RESETALL

Some issues with the software might be able to be rectified by activating the RESETALL command.

This deletes all historical Steelwise information from the computer's registry, thus all user applied settings will revert back to the default settings as if it was a brand-new install on a clean computer.

14.1.2 A3D - Frames Not Lining Up

If for some reason your trusses, wall and/or joists are not lining up with each other in the 3D Model Space, firstly check that you have inserted your reference markers (REF) on the layouts prior to building your frames. If you are sure this procedure has been followed correctly, try turning off your 3D by activating the A3D command, then turn the individual layouts by using the J3D, P3D and T3D commands.

14.1.3 Checklist

In both the SUM and REP reports, there is now a 'Checklist' tab. This is designed to be printed out for the factory as a manual checklist for the factory for Rolled, Built and Stacked frames.

ID	Rolled	Built	Stacked	ID	Rolled	Built	Stacked
Wall Frames:							
L1 (1)	<input type="checkbox"/>	<input type="checkbox"/>	<input type="checkbox"/>	L10 (1)	<input type="checkbox"/>	<input type="checkbox"/>	<input type="checkbox"/>
L11 (1)	<input type="checkbox"/>	<input type="checkbox"/>	<input type="checkbox"/>	L12 (1)	<input type="checkbox"/>	<input type="checkbox"/>	<input type="checkbox"/>
L13 (1)	<input type="checkbox"/>	<input type="checkbox"/>	<input type="checkbox"/>	L14 (1)	<input type="checkbox"/>	<input type="checkbox"/>	<input type="checkbox"/>
L15 (1)	<input type="checkbox"/>	<input type="checkbox"/>	<input type="checkbox"/>	L16 (1)	<input type="checkbox"/>	<input type="checkbox"/>	<input type="checkbox"/>
L17 (1)	<input type="checkbox"/>	<input type="checkbox"/>	<input type="checkbox"/>	L18 (1)	<input type="checkbox"/>	<input type="checkbox"/>	<input type="checkbox"/>
L19 (1)	<input type="checkbox"/>	<input type="checkbox"/>	<input type="checkbox"/>	L2 (1)	<input type="checkbox"/>	<input type="checkbox"/>	<input type="checkbox"/>
L20 (1)	<input type="checkbox"/>	<input type="checkbox"/>	<input type="checkbox"/>	L21 (1)	<input type="checkbox"/>	<input type="checkbox"/>	<input type="checkbox"/>
L22 (1)	<input type="checkbox"/>	<input type="checkbox"/>	<input type="checkbox"/>	L23 (1)	<input type="checkbox"/>	<input type="checkbox"/>	<input type="checkbox"/>
L24 (1)	<input type="checkbox"/>	<input type="checkbox"/>	<input type="checkbox"/>	L25 (1)	<input type="checkbox"/>	<input type="checkbox"/>	<input type="checkbox"/>

To print the checklist, go to the 'Checklist' tab and click on the 'Print Current' button at the bottom of the dialogue box.

14.1.4 Command Aliases (Shortcuts) Missing

If the Steelwise alias commands do not work after loading the software, you can reload them by typing in the DO_ONCE command.

14.1.5 Command Bar Missing

If, for some reason your Command Bar has disappeared, there are a number of options to turn it on again.

1. Click anywhere in a blank area of the Status Bar at the bottom of program display. This option is possibly the most common reason the Command Bar may have disappeared in the first place.
2. Press Ctrl+9 to turn it on or off.
3. Right click anywhere on the Menu Bar and select it from the display options.
4. In the Menu Bar go to View – Display and select it from the display list.
5. In the Ribbon menu go to View – Display and click on Command Bar.

14.1.6 Copy

The Copy command uses the standard IntelliCAD COPY command instead of the old Structure MEMBER_COPY command. This means that when copying multi-faceted members such as trusses, all the components must be selected i.e. overhangs and truss markers. This resolves some of the crashing issues associated with the MEMBER_COPY command.

14.1.7 Creating a Custom Border

By default, the FRAMECAD Steelwise border setup routines use a border called 'BR FRAMECAD'. However, customers have the facility to create a customized border to reflect their company's image.

There is a blank border located in the 'C:\ProgramData\FRAMECAD\FRAMECAD Steelwise\Blocks' directory called 'BR Blank Border.dwg'. To create a custom border, open this drawing in Steelwise and use the 'Save As' command to rename the drawing to the desired name. You must keep the 'BR' with a space after in the name.

In the blank border, a space has been left where you may insert your company logo or any required text. You may alter or rearrange any text within the blank border as you see fit. Lines may be copied, moved or erased as required.

Please do not delete any of the attributes. These attributes are vital to the border's operation. Existing attributes may be moved or rearranged as required. If desired, attributes visibility may be changed from visible to invisible.

When inserting your company's logo, make sure they are in dwg format. Inserting bitmaps seldom work and is generally a waste of time. Also watch the size of the logo used. There is no point creating a custom border if it winds up several megabytes in size. Whilst the border may look pretty the speed penalty taken will certainly overrule the file size.

The FRAMECAD logo can be moved but it must remain present within the border.

Once you have created your custom border you must go to BSET and change the border name to the same as which you have called your filename.

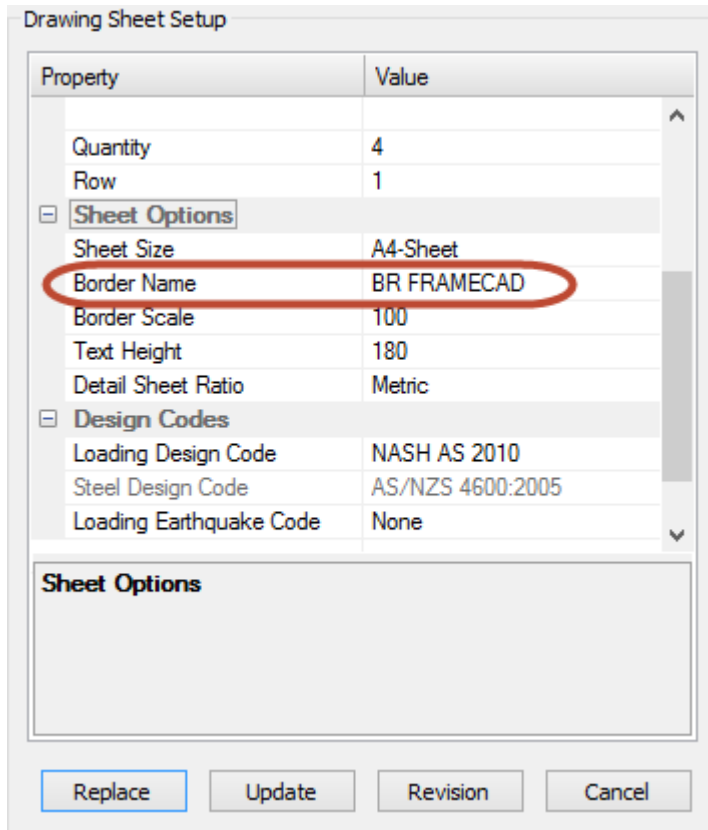

14.1.8 Data File Updates

Whenever a data file is updated, any setting changes will only be obvious if you change to another data file then change back again in the settings dialogue boxes. Some changes also require the Model Name to be changed to a different model then changed back again.

14.1.9 ELEVATIONLINE Command Not Recognised

If the **ELEVATIONLINE** command is not recognised, run the **AECOBJECTS** command and ensure it is set to **'ON'**. The program will need to be restarted for any changes to take effect.

In later versions of the software, this is done automatically, however the user will be prompted to save their job and restart the software before the setting will take effect.

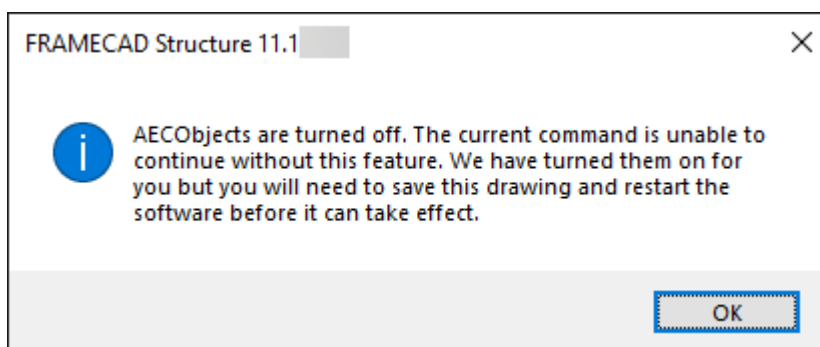

14.1.10 Export

14.1.10.1 Export As...

Exports job to various file formats such as pdf, svg, bmp, wmf, emf, dwf, stl, dae.

14.1.10.2 Nexa Upload

14.1.10.3 RFY Export

Launches the RFY Export dialogue for RFY Rollformer file creation.

Refer to section 4.5

14.1.10.4 PDF Export

Creates a single pdf file of the selected borders.

Refer to section 4.4

14.1.10.5 CNC Export

Creates an XML file in the C:\Documents\CNC directory from the current detailing space tab.

14.1.10.6 ACNC Export All

Creates XML files from all detailing space tabs at once.

- Type ACNC
- Separate XML files will be created in the C:\Documents\CNC directory for each existing detailing space tab.

14.1.10.7 VRML Export

Creates a 3D .wrl file to be viewed in other software (e.g. SAP Enterprise).

- Create a 3D view of the plan in the Model Space by using A3D or T3D/P3D/J3D.
- From the Model Space, use the VRML command.
- A .wrl file will be created in the C:\Documents\CNC directory.

14.1.10.8 IFC Export

Creates an .ifc file for use in other software (e.g. Tekla, Revit, SAP, etc.)

Refer to section 4.3

14.1.10.9 STP Export

Creates an .stp file for use in other software (e.g. SolidWorks).

14.1.11 Exporting Gridlines to IFC

Use the C3D (CopyModel) command to copy the gridlines from the Layout space to the Model space, then create the .ifc file using the IFC command.

14.1.12 File Dialogue Boxes Missing

'Save As' or 'Open Drawing' dialogue boxes are missing. Some other dialogue boxes are also affected. To rectify this issue, run the FILEDIA command and set to 'ON' by either typing in 'ON' or '1' in the command line.

14.1.13 Imperial Measurement Input Method

Imperial measurements are generally shown as 8'-6 1/2", but must be typed in as 8'6-1/2" when inputting values on the command bar.

You **can't** include a space as the space bar performs the same function as the Enter button or right mouse click.

14.1.14 Importing an Architectural Into a Job as a Block

- Open the dwg/dxf file in Steelwise.
- Freeze any unwanted layers on the plan (using the LF command will help with this).
- Go to 'Save Block to Disk' in the 'Tools' menu.
- Click on the 'Select Entities' icon.
- Set the name and destination to save the block.

14.1.15 Importing IFC file into REVIT

1. If you haven't before, define the IFC Import Options to a setting that matches the type of structures and BIM model you are trying to achieve. To do that, select the "R" button (1) then select the right arrow next to 'Open' (2) and select 'IFC Options' (3) as shown below.

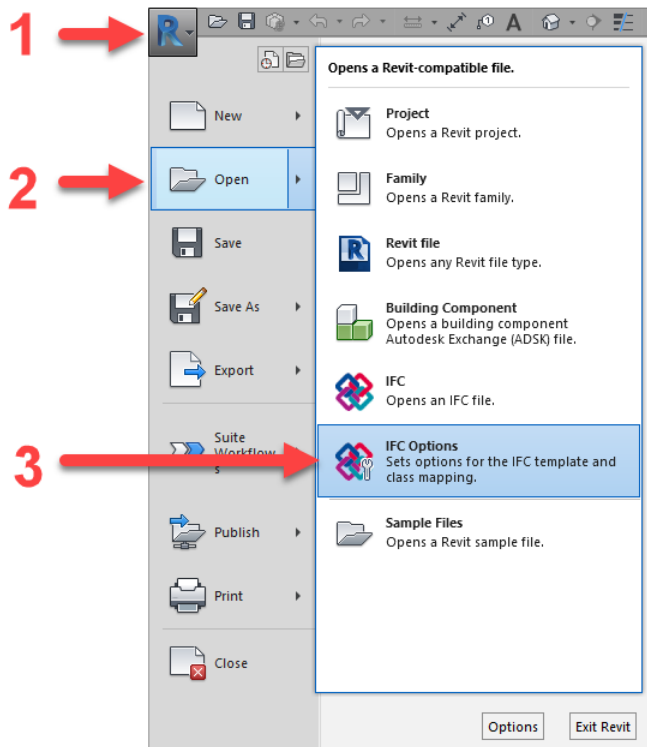

2. In the IFC Options dialogue box, select the template to use for IFC Imports (1) and define the Revit Category to use for each IFC Class / Type (2)

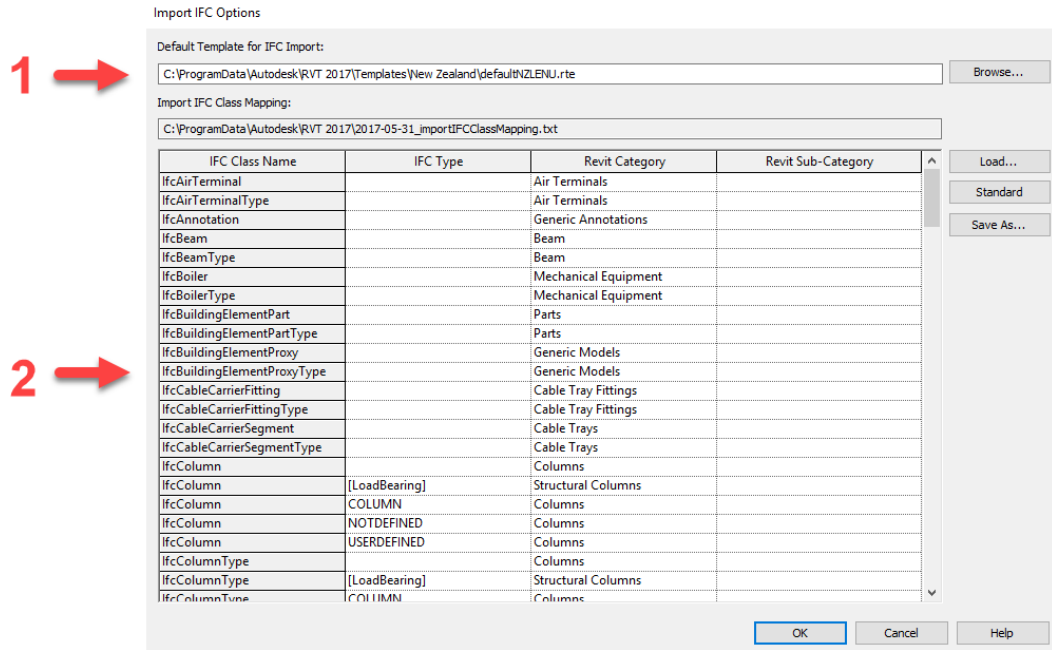

- Once all your settings are defined, import the IFC file. To do that, select the "R" button (1) then select the right arrow next to 'Open' (2) and select 'IFC' (3) as shown below.

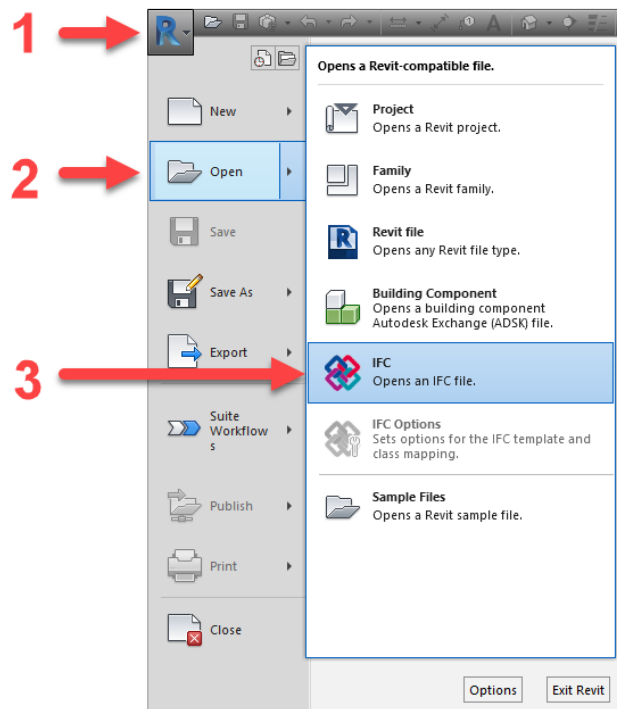

14.1.16 Labelling Issue

Wall, beam, truss and joist labels must not start with an 'X' as X is the default value used for unlabelled frames.

14.1.17 Menus – How to Resolve Missing Menus

If the Steelwise menu is missing from the menu bar when loading the software, you can reload it by activating the DO_ONCE command.

14.1.18 **Mirroring Jobs** (New)

This is a general guide only – some trial and error may be required to ensure that you get the correct desired outcome.

Wall Frame Layout

- Mirror the wall layout
- Turn off (LF) or delete (LE) the studs.
- Run the Panel_Reverse (RF) command on any walls that you want to view from the opposite side.
- PUA the walls to update the studs. Run LS to show the studs if you ran the LF command in step 2.
- Re-PPD the walls.
- Re-P3D the walls.

The above steps will also depend on the complexity of the job and how much editing has initially been done.

Truss Layout – LE Inline Truss System

- Mirror the truss layout
- No other steps are required

Truss Layout – LC Back-to-Back Truss System

- Mirror the truss layout
- Re-TTD the trusses

Floor Joist Layout

- Mirror the floor layout
- No other steps required

14.1.19 **Move**

The Move command uses the standard IntellCAD MOVE command instead of the old Structure MEMBER_MOVE command. This means that when moving multi-faceted members such as trusses, all the components must be selected i.e. overhangs and truss markers. This resolves some of the crashing issues associated with the MEMBER_MOVE command.

14.1.20 **PCB (Calculate Wind) Not Working**

Ensure you have reference markers (REF) on your plans.

14.1.21 **PDF (PDFSPOOL) Bad Fonts**

The fonts on pdf exports appear as hieroglyphics rather than proper text. This is due to the fact that fonts are not embedded into the pdf. As a result, the device that you try to view the pdf on may not have the matching fonts installed in it. This is a bigger issue with Apple devices as Apple choose not to conform with anyone else.

In the PDF dialogue box there is an option to tick on 'Embed TTF Fonts' and 'Convert TTF fonts to graphics'. Tick the first option to see if this resolves the issue. Failing that, try the second option as well. The only downside is that the file size of the pdf will increase.

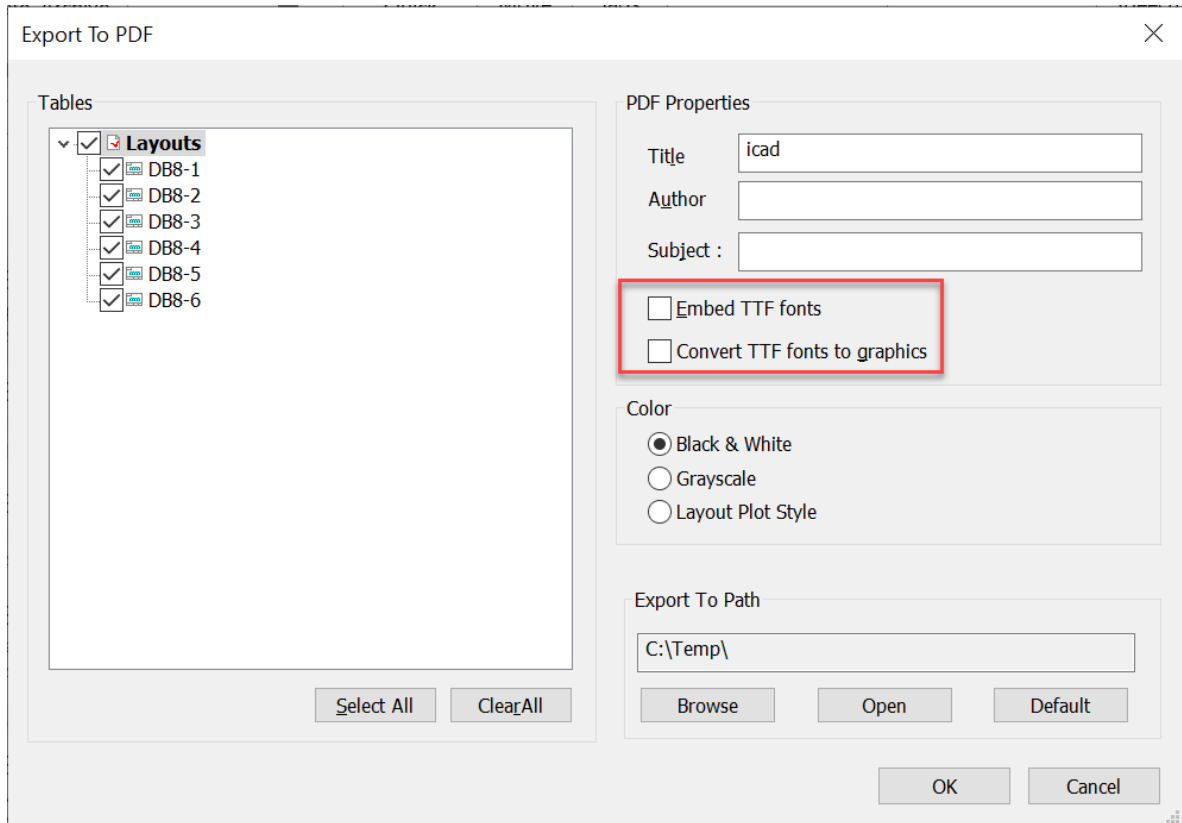

14.1.22 PDF (PDFSPPOOL) Not Working

In version 8.1.100.9 and later, the border logo had been updated which may cause issues with the PDF command for some users with custom borders. This also depends on how the custom border has been created. In these cases, you will need to send the file through to FRAMECAD to be edited.

The use of 'Splines' within custom border logos or any imported details will also cause issues with the PDF functionality. Splines must be converted to polylines.

14.1.23 REF – Multiple Reference Marker Placement

To add reference markers to every border in the same location, hold the 'Alt' key down while placing the Primary marker.

14.1.24 Restoring an 'AutoSave' Drawing

To restore an 'AutoSave' drawing:

- Go to Tools – Options on the menu, go to the Paths/Files tab, expand the 'Auto backup' section, right click on the directory location displayed and select 'Open Containing Folder'.

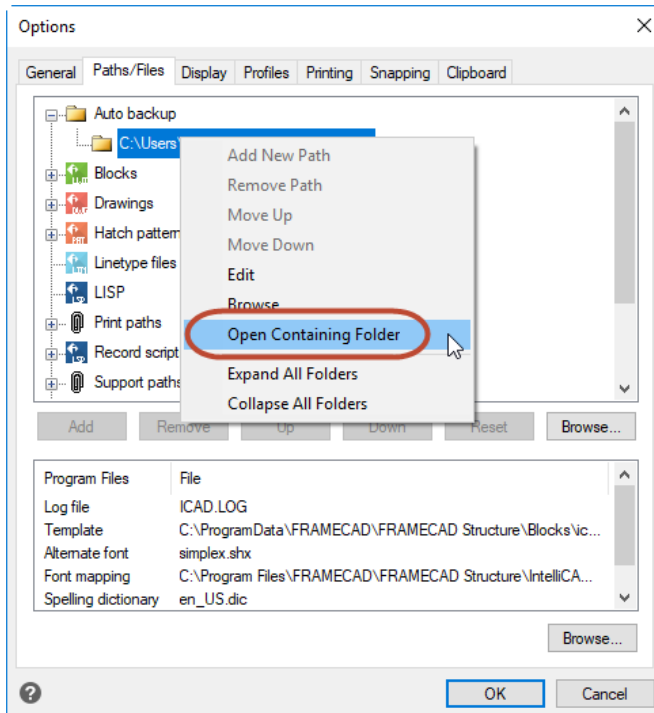

- Find the file of the appropriate name. Sort the files in order of 'Type' if this makes searching easier. You will be looking for files under the 'SV\$ File' type.
- Copy the file to the directory where you would normally keep your job files.
- Change the files extension name from '.SV\$' to '.dwg'.
- Open the file as normal in Steelwise.

14.1.25 Scroll Between 3D Views

Use VV to scroll between various 3D views.

14.1.26 SECTION MARK

Cross section markers can be added to a drawing using the SECTION_MARK command.

14.1.27 SECTIONLINE Command Not Recognised

If the **SECTIONLINE** command is not recognised, run the **AECOBJECTS** command and ensure it is set to **ON**. The program will need to be restarted for any changes to take effect.

In later versions of the software, this is done automatically, however the user will be prompted to save their job and restart the software before the setting will take effect.

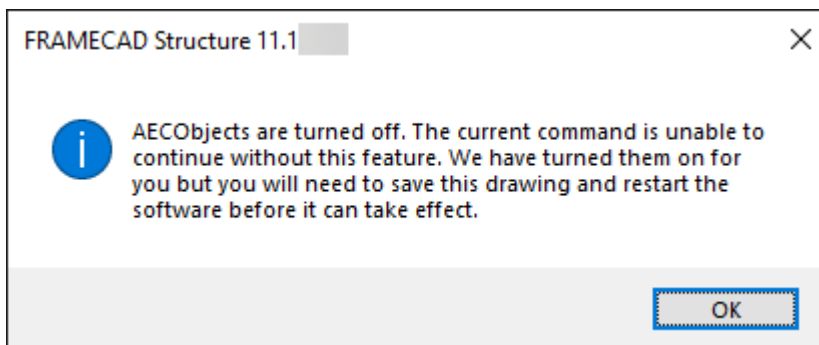

14.1.28 **SHOW – Engineering Failures**

To show engineering failures press return while in the command.

14.1.29 **STRIP – Strip Entity Property Intelligence**

Strips any of Steelwise's entities of all property intelligence.

This is useful when copying walls or beams to another layout for set out purposes, e.g. using walls or beams on a joist layout for better clarity when inputting joists. If these members are left as they are, you end up with a double up of members in the job. You must not combine walls, trusses and joists on the same layout plan as it will cause issues with labelling, frame building and reporting.

Exploding entities does not remove the data. If you explode them, you end up with a series of individual lines that still contain entity data. Stripping the data from these entities also leaves them as complete polylines.

14.1.30 **SUM – Report Summary**

Provides a material summary report for all the individual tabs and a total job summary.

14.1.31 **TEMPHIDE**

Allows to temporarily hide an entity (or entities).

14.1.32 **-TTD – Truss Builder (Silent)**

This command allows the user to re-engineer a given truss from within the elevation view (detailing space).

What this means is that when modifications are made to a truss in elevation view (detailing space), the user can then re-engineer the truss without bringing up the Truss Builder dialogue box, which can result in the truss reverting back to its original state prior to any modifications when clicking on the Update button.

It also allows you to build trusses from the layout while by-passing the Truss Builder dialogue box.

14.1.33 **Using Viewports (Standard IntelliCAD usage not directly related to Steelwise usage)**

The maximum number of viewports that can be opened in one tab is 64, which is the same limitation as AutoCAD. However, there is also a 'SETVAR' called 'MAXACTVP' which also limits the number of viewports (value must be between 2 and 64). By default, the 'MAXACTVP' is set to 48. To increase its quantity to the maximum, just type 'MAXACTVP' in the command line and increase the quantity as required. Should more viewports be required, I would suggest that the user starts off a new tab, as there is no way around the 64 limitation.

14.1.34 **VM – Make View**

In addition to being able to make new views in Detailing Space, use the following steps to update a wall, joist or truss frame in the detailing space.

This assumes that the wall, joist or truss frames have already been built and you need to rebuild one or more frames but don't want to re-export all the frames again. The reason for this could be because too much editing has already been carried out on a number of existing frames.

- Re-export the required frame(s) to a new tab.
- Delete the old frame from the border in the initial tab.

- Copy the new frame into its place.
- Type VM then press Enter.
- Enter the number of the border view.
- Select the view area by selecting the opposite corners of the border.
- Delete the new tab.

14.1.35 X – Previous Zoom

Enter 'X' to go to the previous zoom.

14.1.36 Zone Labelling

When Listing (LI) walls, trusses or joists, the listing dialogue box shows an option in General Information called 'Zone Location'. This allows a selection of entities (walls, trusses or joists) to be grouped into areas.

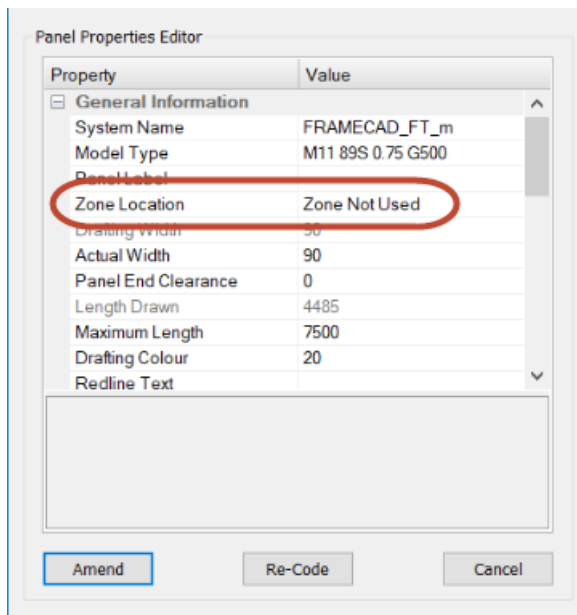

To use this, select and list (LI) a group of walls or joists, then in the Zone Location, overwrite 'Zone Not Used' with a label that best describes the location of the selected frames, e.g. Unit1. Select the next set of frames and type in Unit2. When you perform a PPD, TTD or JJD, these frames can then be filtered by zone when building. The zone label will be shown in front of the panel or joist label in the elevation views.

In PSET – Options – Labelling Option Information, you can set 'Restart Zone Numbering' to 'False' to have continuous numbering through all zones, i.e. all numbers will only be used once and not repeated.

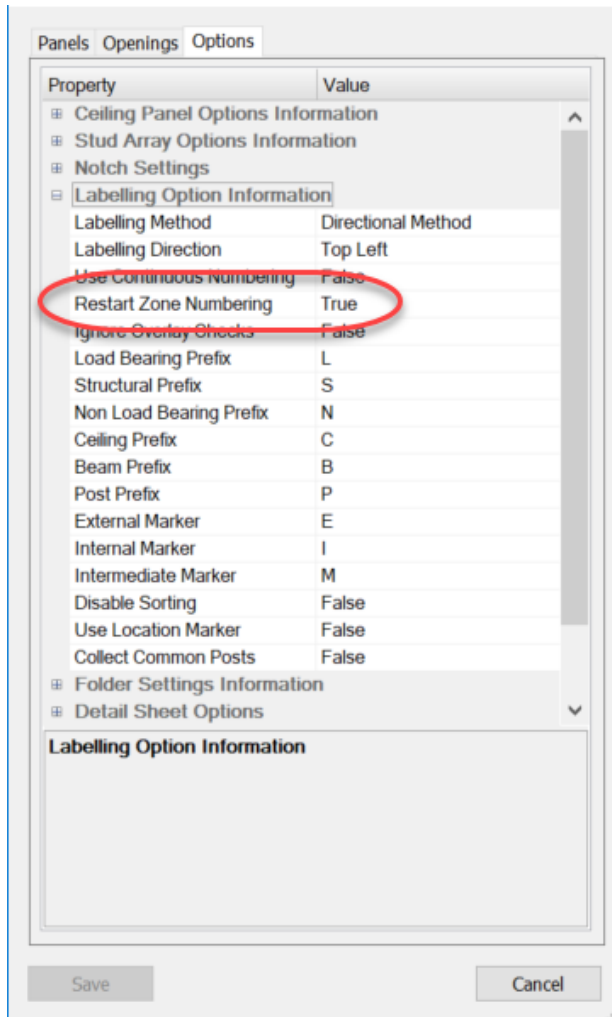

Note: Do not start the zone location description with 'Z' or 'X' or a number. Description length must be greater than 2 characters long and is limited to 6 characters. Spaces will be eliminated. This option is ideal for large commercial or multi-unit buildings.

14.1.37 ZZ – Toggle Tabs

Switches between current tab and last active tab in a job.

14.2 Floor Detailing

14.2.1 Add or Amend Floor Beams

- Make sure you have the correct System Name selected in the PSET settings.
- Activate the ADD command and go to the Joist tab
- Ensure you have the correct System Name selected
- Hold the ALT key down and left mouse click on 'Member*'. This will open a Floor Beam Editor dialogue box. Please contact your system administrator if access is denied.
- Add or amend floor beams as required.
- Click on Add/Amend.

Adding or amending floor beams will create a new user data file in the C:\ProgramData\FRAMECAD\FRAMECAD Steelwise\Library directory with the same name as the System Name selected but with 'USER' at the end of the name. Any information within this data file will take precedence over the parent data file.

14.2.2 Adjusting Floor Joist Web Spacing

Floor Member Editor - Web Spacing

When changing the depth of a joist, the user must List (LI) the joists and change the web spacing under Material Information. This should be changed to be equivalent to the joist depth to achieve an approximate web angle of 45°. The default web spacing is set to 300mm.

14.2.3 Automatically Hide Layout Layers on PPD (PSET – Options)

Detail Sheet Options:

'Hide After to CAD' gives the option to hide (or leave unhidden) the following layers: Opening Label, Panel Brace, Panel Opening, Panel Stud. Leaving these layers hidden allows for an uncluttered plan for easier viewing on site by the framing erector.

14.2.4 Deep C Floor Joists – Creating RFY File to Send to Rollformer

When detailing a deep C floor layout in Steelwise, you must create the RFY file from within the layout space. You don't need to build (JJD) the deep C joists as there is nothing to build. The only reason you may wish the JJD them is to see the engineering results.

14.2.5 Deep C Floor Joist – Service Hole Engineering

Scenarios:

For pre-existing system data files and jobs where the 'Standard (service) hole included' option in the Floor Member Editor is set to 'False' – holes are not considered.

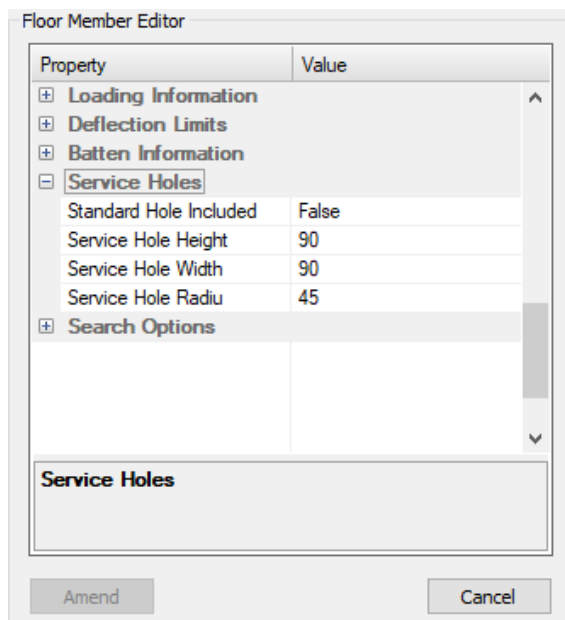

The Detail Design Drawing in the Joist Builder (**JJD**) specifies hole end distances that puts holes outside web crippling zone.

DESIGN LOADING		SERVICE HOLE		BR	
FLOOR NOTES: 1. Joists and Bearers NOT designed for any applied wall loads. 2. Engineer to spe es: Type Gravity (Dead) Floor Live Load Concentrated Live		No Service Holes Considered for Engineering		No Lip Cuts permitted Provide Chord Restraints at s Provide Intermediate Span Br Member Effective Lengths fo Type Kx Lx Ky Member 1.0 Panel 1.0	

Pre-existing data file and jobs where "service hole included" option in Floor Member Editor has been set to 'True', or has been changed and service hole lines drawn: - holes considered anywhere, but with minimum edge distance of 10 inches (US Standard). One-page report specifies 10"-hole end distances.

DESIGN LOADING		SERVICE HOLE				BRA	
FLOOR NOTES: 1. Joists and Bearers NOT designed for any applied wall loads. 2. Engineer to spec es: Type Gravity (Dead) Floor Live Load Concentrated Live		Type	Height	Width	Hole Edge	No Lip Cuts permitted Provide Chord Restraints at sp Provide Intermediate Span Bra Member Effective Lengths for Type Kx Lx Ky Member 1.0 Panel 1.0 Panel 'denotes distance betwe Rest. 'denotes lateral restrain	
		90x90	90.0	90.0			
		Minimum Clear Distance to Support:					
		Interior Support: 254 mm					
		End Support: 254 mm					
		Minimum Clear Hole Spacing: 450 mm					

New hole data file system:

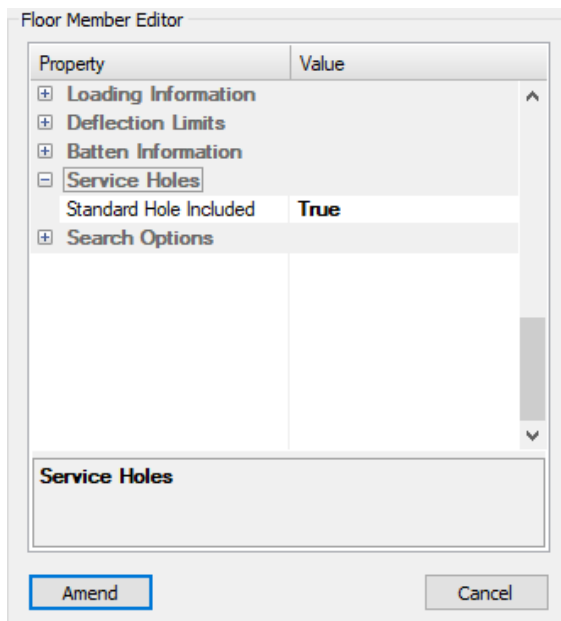

Where "service hole included" option in joist LI has been set to 'True' - holes considered anywhere, but with minimum edge distance of 10 inches (US Standard). The one-page report specifies 10"-hole end distances.

Where service hole lines are drawn - holes are considered at the drawn location. The one-page report specifies the hole locations.

14.2.6 Detail Sheet Border Size

'Border Sized to Fit' option added which makes all the floor joist elevation borders the same size if preferred. The 'Detail Sheet Options' can be found on the 'Others' tab in JSET.

14.2.7 Floor Member Summary – No Ceiling Batten Material Displayed

If you require ceiling batten material to show in the Floor Member Summary, you must make sure that you have set the Ceiling Batten Spacing value in the Joist Settings (JSET).

14.2.8 Move Joist Labels

To move a joist label in v8.1.8 and later, the user can select the grip on the centre of the label and move it horizontally or vertically. Also, the STRETCH command can be used by dragging a right to left selection box over the label and moving it by base point and displacement point or distance.

Likewise, if a series of labels needs to be moved, use the STRETCH command and select all the required labels.

14.2.9 Opening Joist in Detail Space from the Layout

When listing (LI) a joist on the layout, the option to 'Go to detailed beam' in the Floor Member Editor will open the joist elevation in Detailing Space.

14.3 Wall Detailing

14.3.1 Add Lintel Plates to a Frame

Lintel plates can be added anywhere within a wall frame in Detailing Space by drawing a line and using the ADD command to code that line as a 'Lintel'.

Note: Lintel plates over openings should only ever be added or changed by listing the opening and making the change in the 'Construction Methods' section of the Opening Editor.

14.3.2 ADD – Beam Heights

The level to the underside of beams is displayed in the **ADD – Beam** dialogue box and the **Panel Coding Editor** when changing a wall to a beam. Changing this value will not alter the Top Level, it will only change the beam height value.

Property	Value
<input type="checkbox"/> General Values	
System Name	FRAMECAD_FT_m
Beam Name*	Webbed Beam
Model Type	Default
Beam Top Level+	2930
Beam Base Level+	2630
Beam Height+	300
Beam Width+	90
Beam Type	Webbed
Drafting Colour	1
<input type="checkbox"/> Creation Options	
Creation Method	By Points

14.3.3 Check Load Path onto Walls

The Load Path (LP) command provides a centre line overlay of the trusses or floor joists over wall frames. To use this command:

- Centralise the wall framing layout on your screen.
- Type LP and Enter. The view will zoom out to display all the borders.
- Click within the border that contains the trusses or floor joists.
- The view will zoom back in to the initial layout with the truss or joist centrelines overlaid.
- If these lines are yellow, then this indicates that all the loads are being transferred correctly.
- If the lines are red, this indicates that no loads are transferred.
- Type LP again to turn the lines off.

Note: If walls are set as “Structural”, then the truss or joist lines will show as being red. The loads are still being transferred but only as evenly distributed loads, not as concentrated loads.

14.3.4 Defined Door Input

For users that prefer to use the ‘Defined Door Input’ options as shown in the Design - Panels/Walls – Layout menu, not all the available options are listed here. Any other required options must be accessed from the ‘Opening’ tab in the ADD command. Double click to select the required option.

14.3.5 Detail Sheet Border Size

‘Border Sized to Fit’ option added which makes all the wall elevation borders the same size if preferred. The ‘Detail Sheet Options’ can be found on the ‘Misc’ tab in PSET.

14.3.6 How to Erase Lintel L Plates and Leave Member Screws

If you delete a lintel L Plate from an opening using the **SE** command, all the screws on the members underneath the plate will also be removed. To stop this from occurring, use the **E** erase command instead.

14.3.7 Inserting Webs into Wall Frames (IW)

- If a member is inserted vertically (or within 5° of vertical), it will snap into place as a vertical stud member.
- If a member is inserted horizontally (or within 5° of horizontal), it will snap into place as a horizontal web member.
- If a member is inserted diagonally from one existing member intersection and then to another existing member intersection, the member will snap to the selected member at a predetermined distance.

14.3.8 MB vs MC on Raking Walls

Do not use the MB (MEMBER_BREAK) command on raking walls. Only the MC (MEMBER_CUT) command will work properly to maintain the correct heights.

14.3.9 Opening Commands

The following commands are used in conjunction with the parameters set in the PSET – Windows options. When a door leaf size is entered into the relevant command, the set clearances are added to create the correct trim opening size in the wall frame.

Alias		PSET Category
AR	Archway Opening (or Square Set Opening)	Nibbed Robe Information
CS	Cavity Slider (Pocket Slider)	Cavity Sliding Door Information
ED	External Door	External Hung Door Information
FS	Face Slider or Surface Slider	Face of Wall Sliding Door Information
R1	Robe Door (Single Door)	Hinged Robe Door Information
R2	Robe Door (Double Bi-fold Door)	Hinged Robe Door Information
R3	Robe Door (Triple Bi-fold Door)	Hinged Robe Door Information
PA	Passage Door (Standard Internal Door)	Internal Hung Door Information
S2	Internal Slider x2	Sliding Robe Door Information
S3	Internal Slider x3	Sliding Robe Door Information
S4	Internal Slider x4	Sliding Robe Door Information

14.3.10 Opening Input by Point

All opening inputs have a 'P' option for placement. This allows the user to select a point which centrally locates the opening on that point.

14.3.11 Openings – Label Options

Label Location – allows the door/window type label to be placed either before the door window size (Pre Fixed) or after the size (Post Fixed). E.g. Pd760 or 760Pd. There is also an option to either leave a space between the label and the size or omit it.

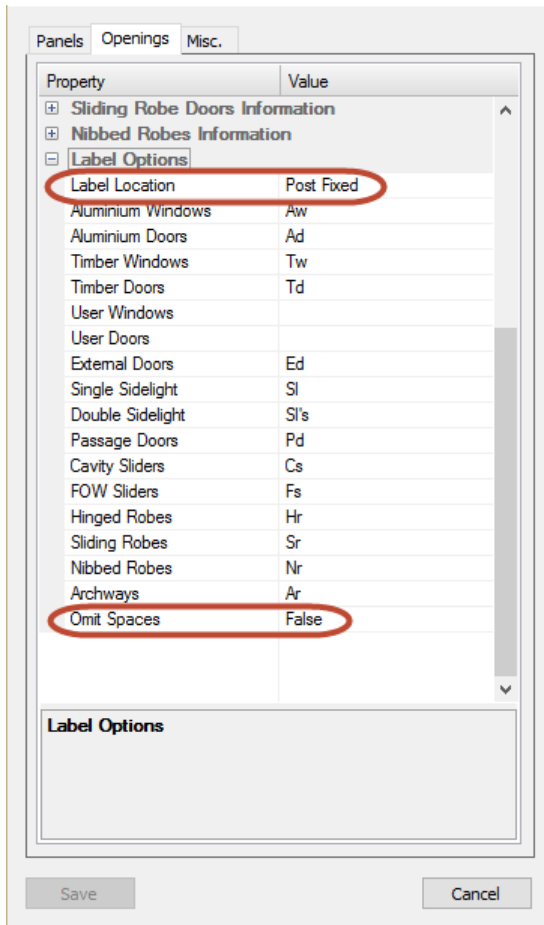

14.3.12 PCB – Panel Calculate Brace

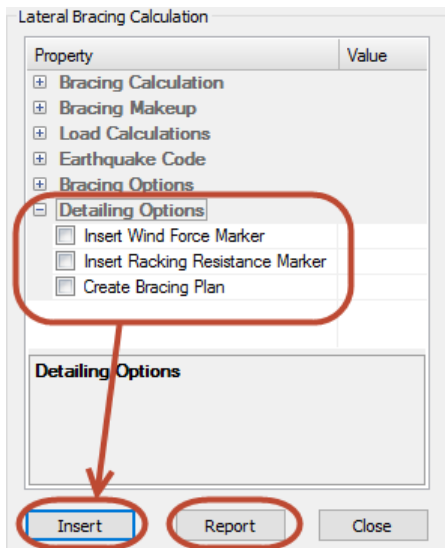

A bracing report can be generated with all the values for the Current Layout and values for each individual wall. The brace report option has been removed from its previous location in the Detailing Options and given its own button at the bottom of the dialogue box.

The Insert option is used to input one of the options selected in Detailing Options or, if nothing is selected, will allow the user to input braces. PIB is also used to input braces without having to activate the Bracing Calculator.

14.3.13 Panel Labelling Options (PSET – Options – Labelling Option)

Labelling Method:

- Traditional Method (old) - Labels all walls from the top left-hand corner of the framing layout in a diagonal direction towards the bottom right.
- Directional Method (new) - Labels the external walls anti-clockwise from the corner of the layout as indicated by the 'Labelling Direction' (walls may be labelled in a clockwise direction if the start walls are lapped differently). Internal walls are then labelled from the same corner then towards the opposite corner of the layout.

14.3.14 Resetting Stud Data

To reset the stud data on a wall(s):

- List the wall or walls.
- Go to the 'Stud Data'.
- In 'Stud Arrangement' select 'Auto'. The Actual and Nominal Stud Spacing will change to 0.
- Select 'Amend' to apply.

14.3.15 SB – Show Brick

This command provides a temporary visual representation of brick veneer (shown as half courses) along a wall to determine whether opening locations are correct in relation to the brick veneer setout. These brick sizings are set in the Brick Gauge options in the Panels tab in PSET.

14.3.16 SH – Show Heights

This command allows the user to view all the walls on a layout infilled with a different solid colour for each different height.

14.3.17 Sill and Head Check

When listing an opening, there is a face wind bending check option that can be activated by setting the Check Sill and Check Head options to 'True'. This can be found in the 'Construction Methods' section. If required, the software will automatically add a boxed sill and/or head stiffener.

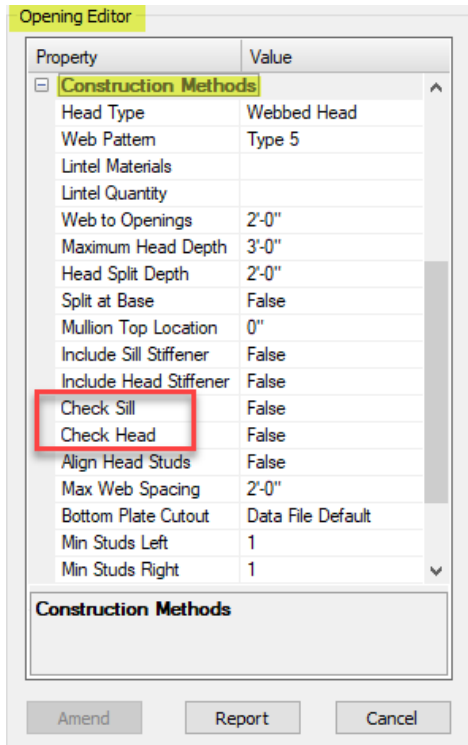

14.3.18 Stud Design

The wall stud design calculations are found in the Panel Builder.

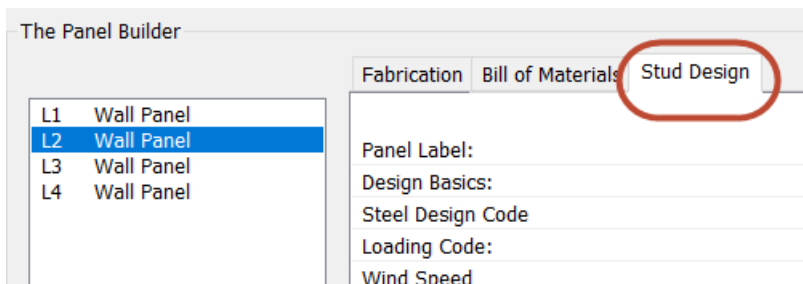

If this tab is not displayed, it means that you probably have the Panel Engineering disabled in the Drawing Sheet Setup (BSET).

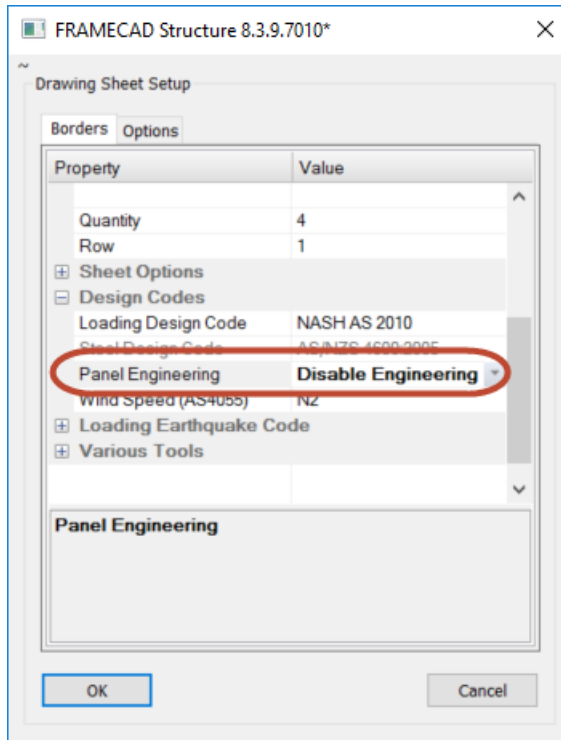

14.3.19 Updating a Wall in the Detail Sheet After Making Changes to it in the Layout

If you have already built (PPD'd) all your walls and now you need to modify one wall in the layout, use the following steps to update the built wall in the detail sheet:

- Make changes to the wall in the layout
- Run the PUA command on the layout
- List the modified wall in the layout and select 'Go to detailed panel' to go to the detail sheet elevation view for that wall
- PPD the wall from the detail sheet to go to the Panel Builder view
- Double click on the panel name in the left-hand column of the Panel Builder to list it
- Click on 'Amend' to amend it to the changes as made in the layout
- Click on 'Update' to update the view in the detail sheet elevation.

14.3.20 Wall Girder Loads

The wall design now evaluates girder load on an opening and includes this load when designing the header. However, this load is still treated as a uniformly distributed load and not a point load therefore an engineer will still be required to check the header or supporting girder truss design for the point load.

A girder load warning message is only applied to the opening header if the supported area on the girder truss is greater than twice the girder truss spacing.

14.4 Roof Detailing

14.4.1 Add or Amend Roof Loads

How to make permanent changes or additions to required roof load types e.g. adding Clay Tiles. Any temporary (or one off) changes should be made in the 'Loads' section of the TSET settings.

- Ensure you have the correct System Name selected
- Hold the ALT key down and click on 'Roof Load*'. This will open a Roof Load Editor dialogue box. Please contact your system administrator if access is denied.
- Add or amend roof loads as required.
- Click on Add/Amend.

Adding or amending roof loads will create a new user data file in the C:\ProgramData\FRAMECAD\FRAMECAD Steelwise\Library directory with the same name as the System Name selected but with 'USER' at the end of the name. Any information within this data file will take precedence over the parent data file.

If you are unable to access the Roof Load Editor, go to your Licence Manager (VER) and see if Sub Edit Feature 2005 is Enabled.

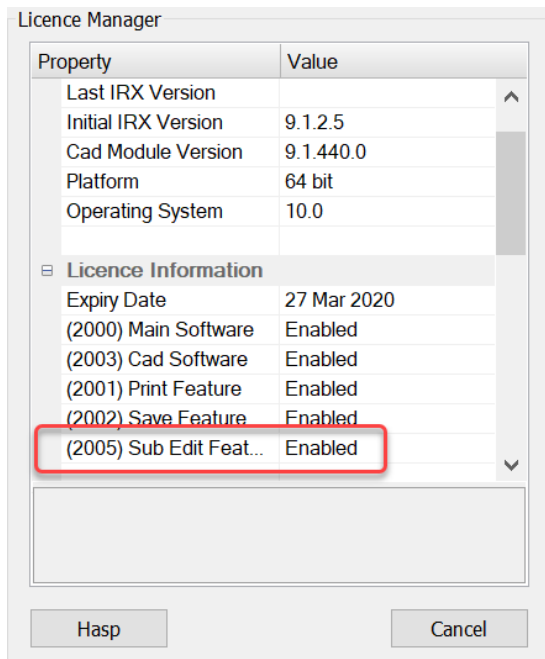

If it is Disabled, you can request it through MyFramecad Care - <https://my.framecad.com/FCADCare>.

14.4.2 ADD – Truss Members in Detailing Space

This command allows the user to input new chord, web or rail members into a truss either by point-to-point input or by entity (coding a line).

Also see IW in the "FRAMECAD Steelwise Reference Guide" under 'Editing Commands'.

14.4.3 Adding External Wind Pressure to Truss Bottom Chords

If your job has trusses which are located in an area of the building that has no walls, e.g. in a carport or porte-cochere scenario, listing those trusses and adding "C" to the end of the wind speed will add extra wind pressure to the whole bottom chord.

Without extra wind pressure:

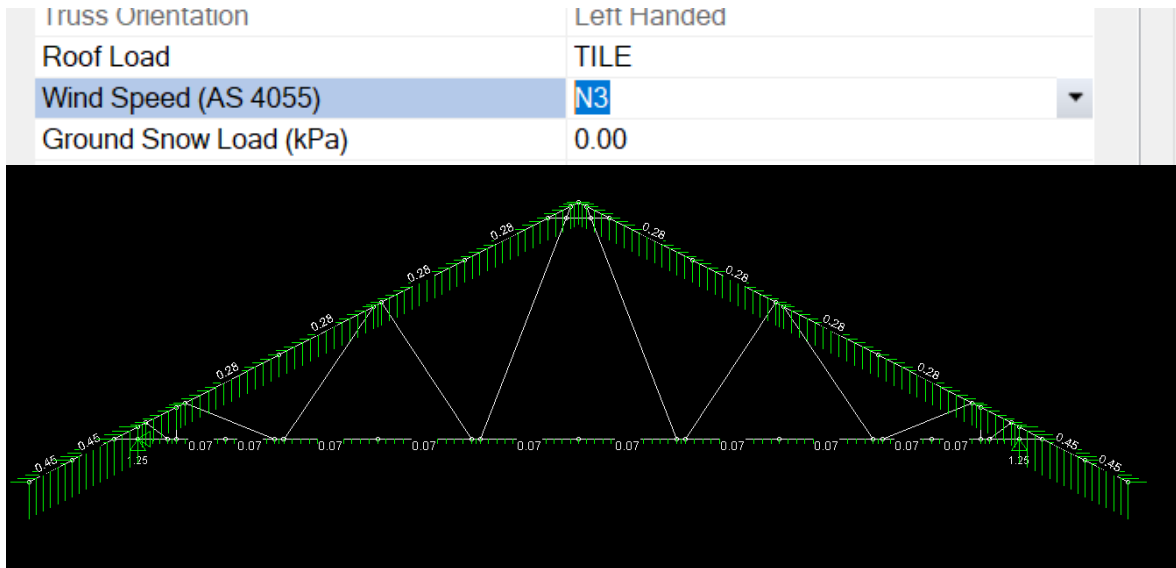

With extra wind pressure added:

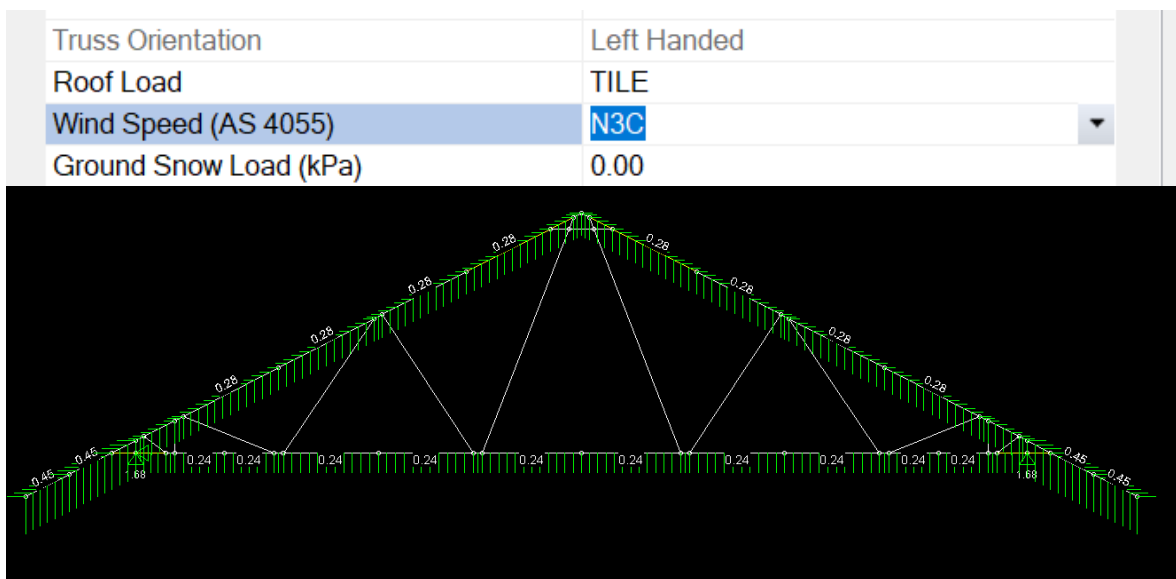

14.4.4 Detail Sheet Border Size

'Border Sized to Fit' option added which makes all the truss elevation borders the same size if preferred. The 'Detail Sheet Options' can be found on the 'Options' tab in TSET.

14.4.5 Gable End Roof Type Truss Locations

There is a data file option to locate the first truss back from the gable end truss, either to the face of the truss or to the centre of the truss. This is a data file setting – please create a ticket in MyFramecad to request any data file changes.

14.4.6 Lengthening and Shortening Trusses Using the Stretch (ST) Command

If a truss is lengthened by using the ST command, what this does is to increase the span of a truss, therefore the trusses heel heights are maintained, the pitch is maintained, and the overall height of the truss is increased, i.e. the apex of the truss is moved.

If a truss is shortened by using the ST command, the apex position and pitch is maintained but the end shortened is going to be a 'cut off' or 'stop end'. Therefore, in effect the heel height is increased on that end of the truss.

14.4.7 Parallel Chord Girder Trusses

When a parallel chord truss supports other oncoming trusses, it will act as a girder. The additional roof area load is added and it's spacing is disregarded. Note: if the parallel chord truss sits on a support line running parallel to it, then the oncoming trusses will load onto the support line and not the parallel chord truss.

14.4.8 Setting the height of truncated trusses

Whenever you manually insert or move a truncated truss you will need to change the height of the horizontal top chord. To do this, you need to list the truss using the LI command, go to the 'Height Information' and click on the button to the right of the Truss Height. You will then be prompted to 'select the truss for reference' – this is the truss that you intend changing the height of. Then you will be prompted to 'select a point for height calculation' – this is the heel line (or support line) of the trusses/rafters which run over the top of the truncated truss.

Note: This operation will not work if you list the truss by double clicking on it. You MUST LI, then select the truss.

14.4.9 TSET – Truss Spacing Types – Truncated Girder Truss

When the 'First Truncated as Girder' is set to 'True', the first truncated truss generated for a hip end will be a girder truss instead of a standard truss. As a result, web members will be aligned with the oncoming hip end trusses and the loads will be calculated using the 'Additional Area' method.

Use this option for roofs with heavy loads or roofs where trusses are cantilevered out to the eaves.

14.4.10 Truss Bottom Chord Restraints

Bottom chord restraints are determined by what is set in TSET – Layouts – Batten Spacing – Ceiling Batten Spacing. If this value is set to zero, then the Ceiling Tie value will be used (TSET – Layouts – Truss Spacings – Ceiling Ties). I.e. the Ceiling Batten Spacing will take precedence over the Ceiling Tie value.

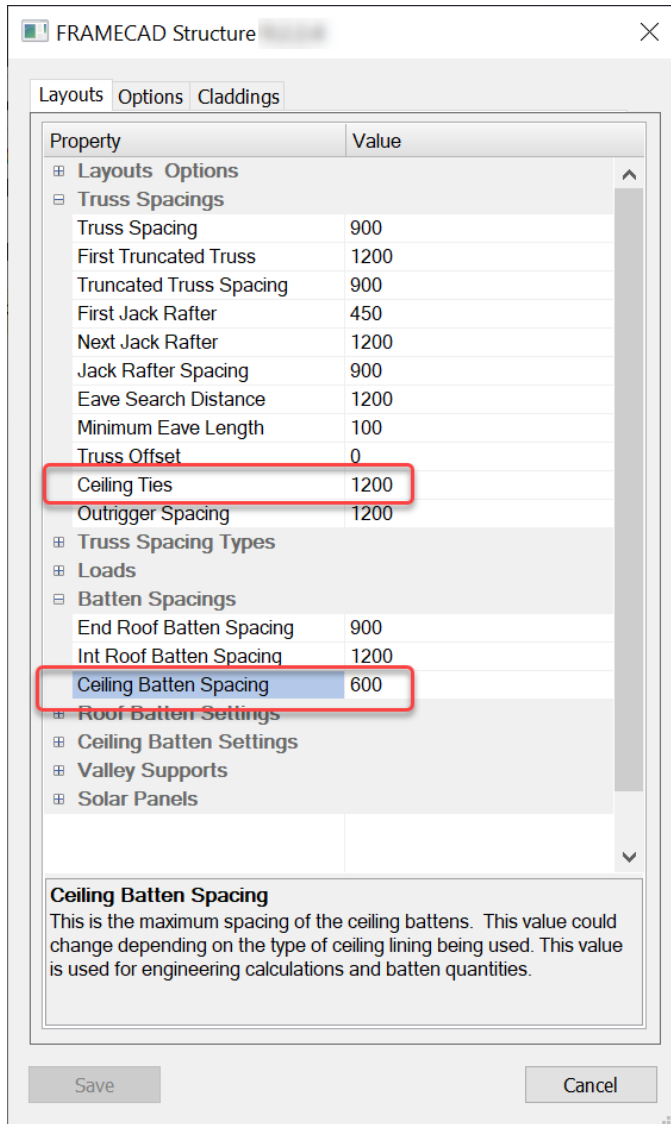

14.4.11 Truncated Truss Horizontal Chord Restraint Message

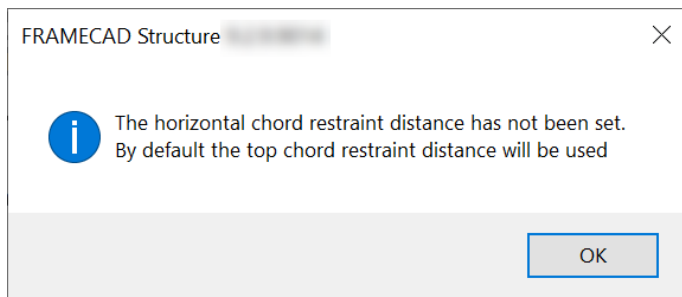

Refer to the Effective Length section in LI – List Item – Truss Editor

14.4.12 Truss Labelling

If experiencing issues with truss labelling at any stage, try using the PUA command first.

14.4.13 TS (Truss Solar) – Solar Panel Input

This command allows the user to input a solar panel (or similar panel) on top of roof trusses. Size and weight settings can be found in TSET.

14.4.14 TTD – Existing detailed trusses not working

If the 'DEFPOINTS' layer is turned off, the software does not bring up the truss as it doesn't find the reference point.

14.4.15 TUP or LP – Blank Screen on Input

If the TUP or LP command is activated, and the plan zooms out to a blank screen when requested to select a location border or source border, this generally means that there is an entity on the plan that exists a very great distance away from border location. If this is true, then follow the process below:

- Type 'e' for ERASE.
- Type 'all' to select all entities in the drawing. A quantity of entities selected will appear in the command bar.
- Type 'r' to remove selection.
- Select entities to remove from selection. The quantity of selected entities will be subtracted from total.
- Press Enter to erase the remaining selected entities.

14.4.16 TUP – Truss Uplift Plan Values

When a truss uplift is plan is created but you don't wish to display all the values below a certain value.

The minimum value can be set in the truss settings 'Report Options' which is in the TSET Options tab.

This is useful if you only wish to display values above a set value for clarity when selecting hold down fixings.

14.4.17 User Truss Creation

User trusses are trusses that follow a roof profile. This is only applicable to truss top chords. Generally, User trusses are an option where a smaller roof block attaches to the end of a hip roof or in other various colliding hip type roofs.

14.5 Smart Panels

14.5.1 Not Initialized

- Run AECOBJECTS and set to 'On'.
- Restart Steelwise.

14.5.2 Add an Opening into a Smart Panel

- Draw a rectangle of the required size and location within the smart panel.
- Type MJ (MEMBER_JOIN) and select the panel.
- Hold the ALT key down and select the opening polyline. All framing in the opening will be subtracted from the panel.

Note: This process can also be used to create notches in the corners and edges of panels.

14.5.3 Rake (Slope or Pitch) a Smart Panel

- List (LI) the smart panel
- Under AEC Basics, change the '3D Raking Angle' to the desired slope.
- Change the '2D Raking Direction' to suit the required slope direction. The arrow indicator on the panel will change to suit.
- The PRA (PANEL_RAKE) command can also be used to rake a smart panel.

14.5.4 How to reshape a Smart Panel on the layout:

- In the layout, run the MD (MEMBER_DIVIDE) command
- Set the number of segments required to divide the side of a panel by (2 will add one extra grip)
- Click on the smart panel
- Once the panel is selected, then click on the segment that you need to add the extra grip(s) to.
- Select the panel to highlight the grips, then click on the grip that you wish to move.
- Stretch the grip to the required location
- Important: LI the panel and go to 'Other Tools – Rebuild Blocks' and activate the 'Press to Rebuild' button
- Now your panel is ready to send to the Panel Builder (SPD) and/or Insert Block

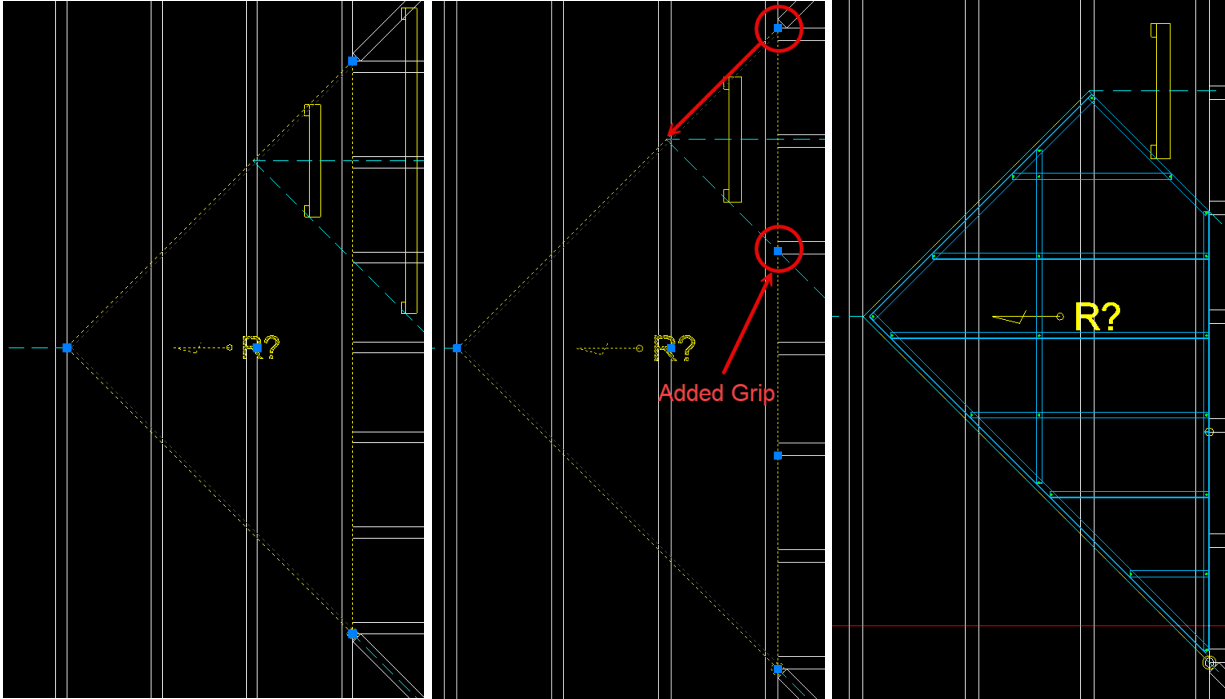

15 Known Issues

15.1 Resolve Graphics Performance Issue

Sometimes the graphic performance of the program becomes erratic. A common cause of this is having too many snap options selected. When initially selecting entity snaps, it is always recommended to only select those which you will commonly use. Here is a recommended list of options.

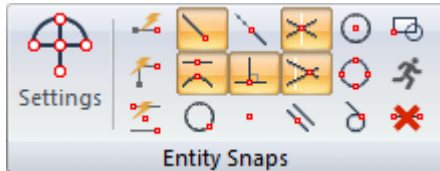

Note that these options will automatically change during the detailing process depending on the command that is initiated.

Other graphics options can be altered by either clicking on the "Switch Graphics Device" button below the command bar to scroll through the three available options:

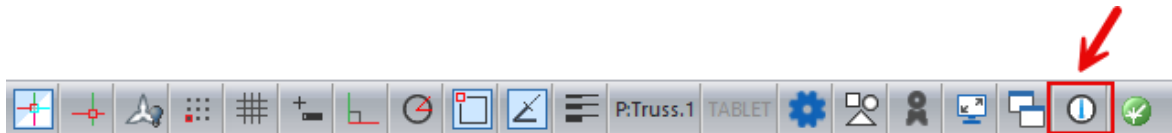

OR right click on the "Switch Graphics Device" button to display the options or to go to the settings dialogue:

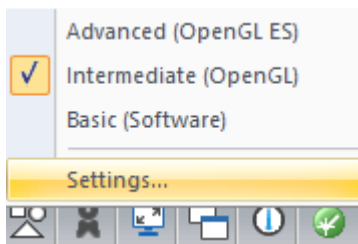

15.2 Erratic mouse movement after a new paper space is created and when performing a command.

Type OPTIONS at the Command: line, select the DISPLAY tab and make sure "Show scroll bars" is not checked. Checking it on causes performance problem (currently known open issue with IntelliCAD).

Too many snap options selected (refer to 15.1 above).

15.3 Aliases not initialising

- Open Steelwise and start a new job.
- Type DO_ONCE
- Check aliases are working
- Save the job
- Close the program
- Re-open Steelwise and see if the issue is resolved.

15.4 Post Input Error Message

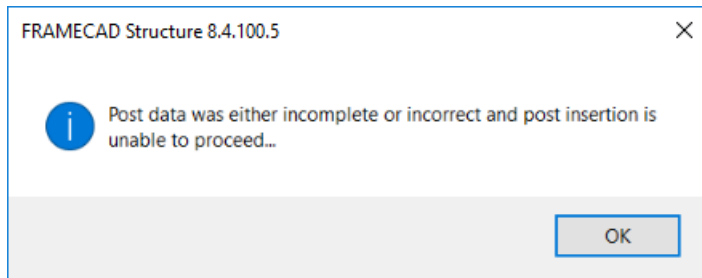

The above message will appear under the following circumstances:

- Post width is less than 25mm
- Post depth is less than 25mm
- Post height is less than 500mm
- Post spacing is less than 500mm
- Post weight is less than 0.25kg

15.5 Smart Panel – ‘Not initialized yet’ Message in Command Bar

- Start Steelwise
- Type ‘AECOBJECTS’ and set to ‘ON’
- Restart Steelwise
- In later versions of the software, this is done automatically, however the user will be prompted to save their job and restart the software before the setting will take effect.

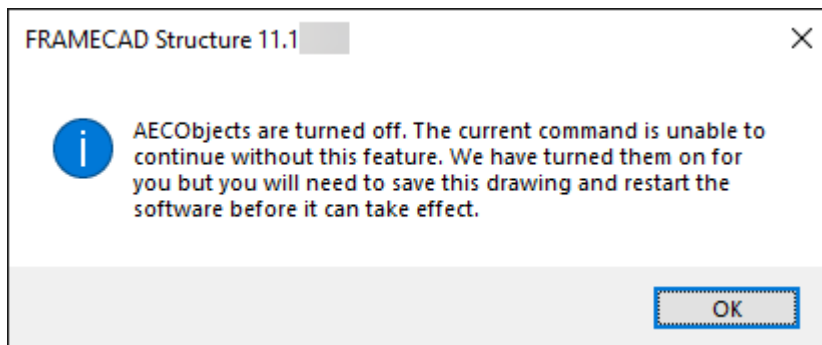

15.6 File Open and Save Dialogue Boxes Missing

If you go to open or save a file and the dialogue box does not appear, run the **FILEDIA** command and enter in 1 to turn ‘On’.

Some imported architectural files can cause this to be turned off.

15.7 Hatching Not Being Displayed

Run the FILL command and set to ‘On’.

15.8 BSET Not Working

Why do all commands work except for BSET?

This is generally caused by a licensing issue where no Design Code features have been enabled in the licence. To double check this, open the Licence Manager dialogue (VER) and check to see if you have a Design Code enabled.